

---

**AutoCAD®  
2013**

---

**3D Tutorials**

---

By Kristen S. Kurland

---

C o p y r i g h t © 2012

AutoCAD is a registered trademark of Autodesk, Inc.

# AutoCAD 3D Tutorials

---

---

AutoCAD®  
2013

---

3D Tutorials

---

By Kristen S. Kurland

---

C o p y r i g h t © 2012

AutoCAD is a registered trademark of Autodesk, Inc.

K 94

## AutoCAD 3D Tutorials

---

### AutoCAD 3D – Chapter 1

€

### 3D Interface

SDVU <sup>-2-</sup> Axborot-  
resurs markazi  
Inv No \_\_\_\_\_

# AutoCAD 3D Tutorials

---

## 1.1 Launch AutoCAD

1. Choose Start, Programs, Autodesk , AutoCAD from the Windows program manager.

OR

2. Double-click the AutoCAD icon from your desktop.



## Workspaces

AutoCAD workspaces are sets of menus, toolbars and dockable windows (such as the Properties palette, DesignCenter, and the Tool palettes window) that are grouped and organized so that you can work in a custom, task-oriented drawing environment.

1. Click the Workspace Switching icon.



2. Click 3D Basics and OK.

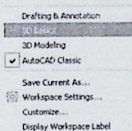

# AutoCAD 3D Tutorials

## 1.2 3D Basics Interface

The following is AutoCAD's 3D Basic interface. The 3D Basic ribbons are as follows:

- Create
- Edit
- Draw
- Modify
- Selection
- Coordinates
- Layers and Views

The 3D Basic pulldown menus are as follows:

- Home
- Render
- Insert
- Manage
- Output
- Plug-ins
- Online
- Express Tools

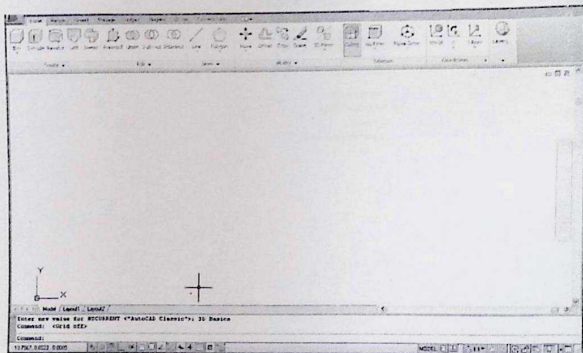

# AutoCAD 3D Tutorials

## 1.3 3D Modeling Interface

The 3D Modeling panels are as follows:

- Modeling
- Mesh
- Solid Editing
- Draw
- Modify
- Section
- Coordinates
- View
- Selection
- Layers and Groups

The 3D Modeling pulldown menus are as follows:

- Home
- Solid
- Surfaces
- Mesh
- Render
- Parametric
- Insert, Annotate, View, Manage, Output, Plug-ins, Online, and Express Tools

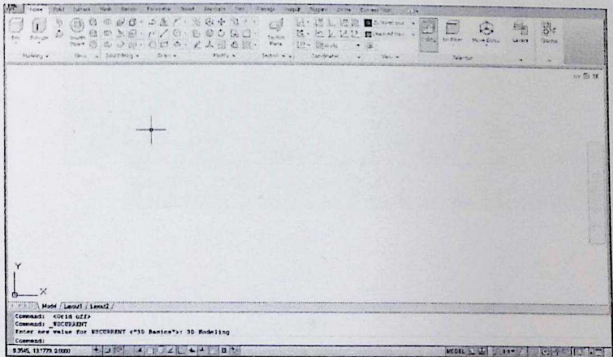

# AutoCAD 3D Tutorials

## 1.4 Viewports

1. Open a drawing or create simple objects as shown below.
2. Click the dropdown menu in the shortcut tools and choose Show Menu Bar.



None Commands...  
Show Menu Bar  
Show Below the Ribbon

3. Choose View, Viewports, 4 Viewports.

OR

4. Type -VPORIS at the command prompt.

Command: -VPORIS

Enter an option

[Save/Restore/Delete/Join/Single/?/2/3/4] 4: enter

Enter a configuration option [Horizontal/Vertical/Above/  
Below/Left/Right] <Right>: enter

Your screen will look something like the figure below with four views in one AutoCAD drawing.

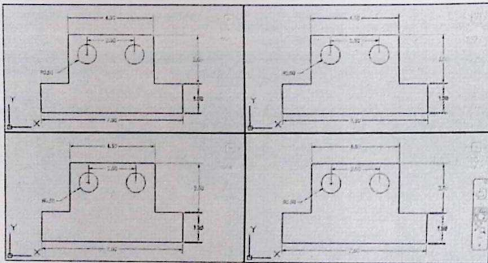

## AutoCAD 3D Tutorials

### 1.5 Preset 3D Viewports

1. Choose **View, Viewports, New Viewports**
2. Click the dropdown option for **Setup** and click **3D**.
3. Choose **Four: Right** as the viewport option.

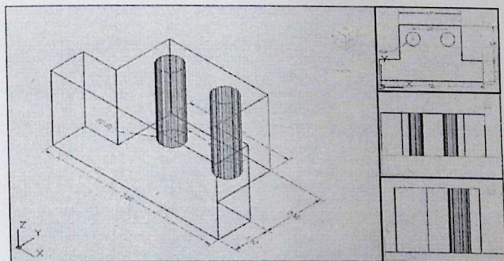
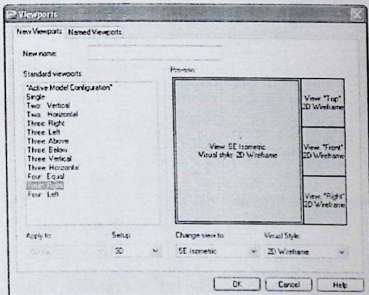

## AutoCAD 3D Tutorials

### 1.6 Named Views

1. Choose View, Named Views...
2. Click the plus (+) sign beside Preset Views.
3. Click NE Isometric, Set Current, Apply, and OK.

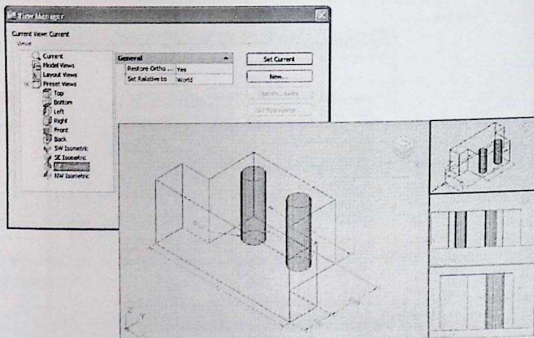

#### Tip:

You can also choose View, 3D Views, and any of the preset 3D views.

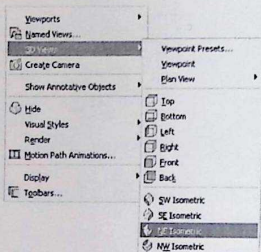

## AutoCAD 3D Tutorials

---

### 1.7 Steering Wheel

SteeringWheels are menus that track the cursor over the drawing window, and provide access to 2D and 3D navigation tools from a single interface.

SteeringWheels, or "wheels," are divided into wedges; each wedge contains a single navigation tool. You can start a navigation tool by clicking a wedge or by clicking and dragging the cursor over a wedge.

#### Full Navigation Wheel

1. Click the Full Navigation Wheel icon.

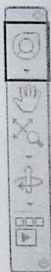

## AutoCAD 3D Tutorials

---

### 2D Navigation Wheel (Zoom/Pan)

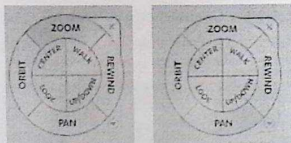

**View Object Wheel** – Center a model and define the pivot point to use with the Orbit tool. Zoom and orbit a model.

**Center**

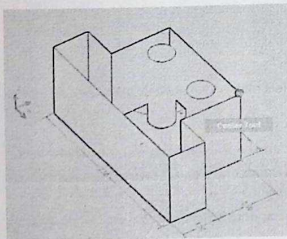
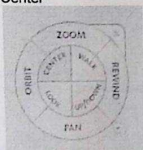

## AutoCAD 3D Tutorials

### Orbit

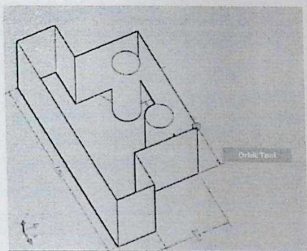

### Look

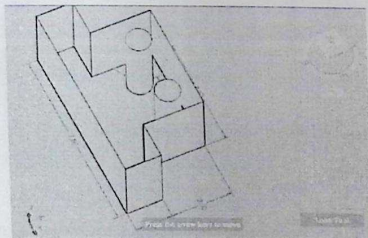

# AutoCAD 3D Tutorials

## Walk/Up/ Down

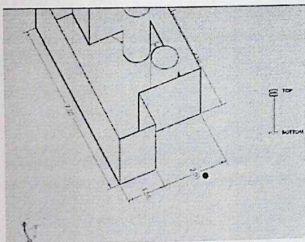
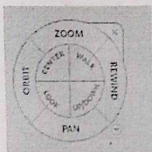

## Rewind

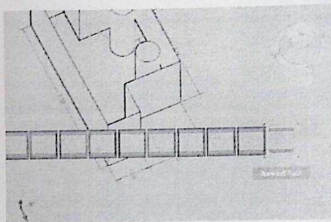

## Shortcuts

1. Right-click on the wheel to view shortcuts.

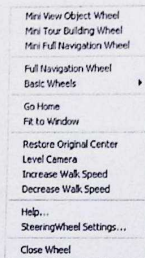

# AutoCAD 3D Tutorials

## Steering Wheel Settings

1. Right-click on the steering wheel and choose SteeringWheel Settings...

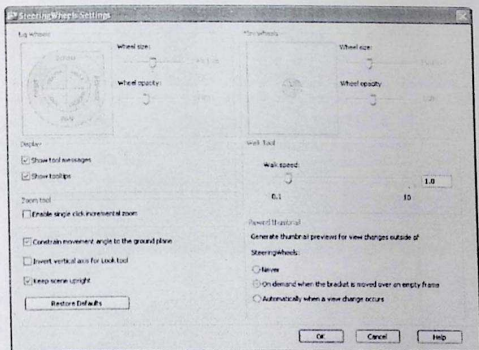

## AutoCAD 3D Tutorials

### 1.8 VPOINT Command (Tripod)

Displays a compass and tripod for defining a view rotation. The compass represents a two dimensional globe.

1. Choose View, 3D Views, Viewpoint  
or
2. Type VPOINT at the command prompt.  
Command: VPOINT  
Rotate/<Viewpoint><-0.614,-0.614,0.500>:  
**PRESS ENTER**
3. Click a point on the compass to define the viewing angle.

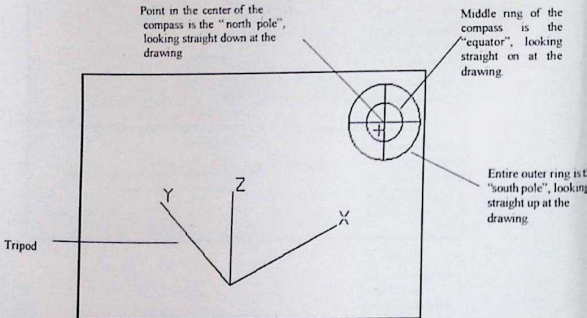

## AutoCAD 3D Tutorials

---

### 1.9 VPOINT Command (Rotate)

Enters a rotation angle at the viewpoint prompt.

1. Type VPOINT at the command prompt.  
Command: **VPOINT**  
Rotate/<View point> <-0.614,-0.614,0.500>: **R (enter)**  
Enter angle in XY plane from X axis <225>: **225 (enter)**  
Enter angle from XY plane <30>: **15 (enter)**

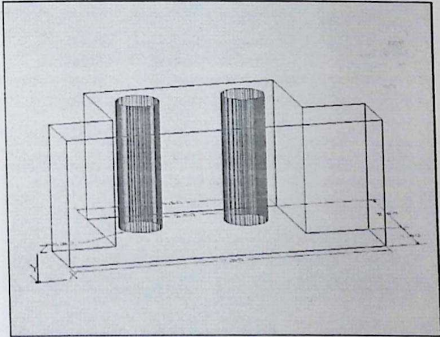

## AutoCAD 3D Tutorials

### 1.10 DDVPOINT

1. Choose View, 3D Views, Viewpoint Preset.  
or
2. Type DDVPOINT at the command prompt.  
Command: DDVPOINT
3. Set a viewing angle by typing the From X axis and XY Plane angle.  
or
4. Pick a viewing angle in the 2 graphics Left graphic = From X Axis  
Right graphic = In XY Plane
5. Click OK.

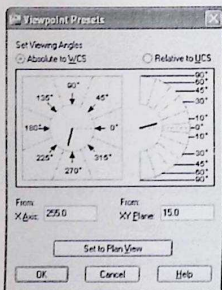

## AutoCAD 3D Tutorials

### 1.11 Plan View

1. Choose View, 3D Views, Plan View , World UCS.  
or
2. Type PLAN at the command prompt.  
Command: PLAN  
Enter an option [Current Ucs/Ucs/World]  
<Current>: World

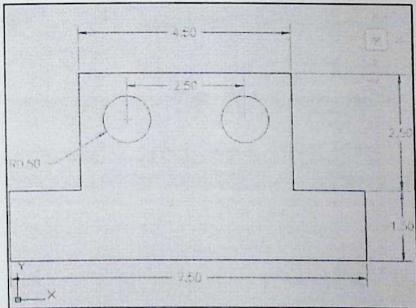

SDVU Amborot-17  
resurs markazi  
Inv No \_\_\_\_\_

©  
**AutoCAD 3D – Chapter 2**  
**Thickness and Elevation**

## AutoCAD 3D Tutorials

### 2.1 Thickness Command

1. Begin a new drawing using a 3D Modeling workspace.
2. Choose View, Viewports, 2 Viewports.
3. Press ENTER for the default of two vertical viewports.
4. Type PLAN and World in the left viewport.
5. Choose SE Isometric for the right viewport.
6. Type THICKNESS at the command prompt.  
Command: THICKNESS  
Enter new value for THICKNESS <0.0000>: 3
7. Draw a 5",2" rectangle using in the LINE command in the left view.

The lines will have a 3D "thickness" that can be seen in the 3D view.

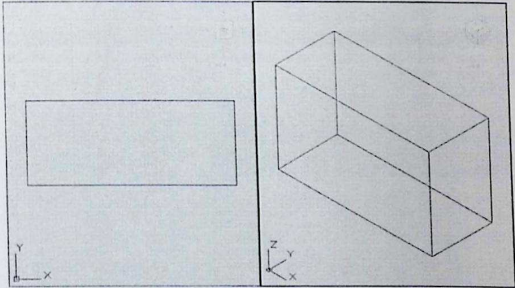

## AutoCAD 3D Tutorials

### 2.2 Change Existing Thickness

1. Select the object whose thickness you would like to change (e.g. one line of the rectangle you drew in 2.1).
2. Choose **Modify, Properties...** or right click and choose **Properties...**
3. Type a new line thickness.

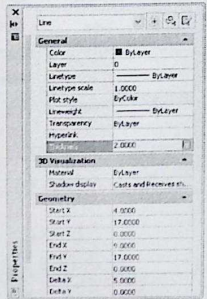

The result is a new line thickness for the selected object.

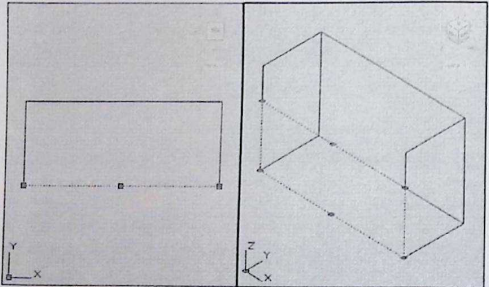

## AutoCAD 3D Tutorials

---

### 2.3 Elevation

Stores the elevation for new objects relative to the current UCS for the current space.

1. Type ELEVATION at the command prompt.  
Command: ELEVATION  
Enter new value for ELEVATION <0.0000>: 1.00
2. Draw two circles in the left view at the new elevation.  
Note that they appear to be "floating" 1 unit above the ground.

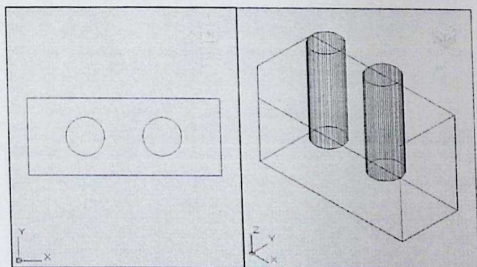

## AutoCAD 3D Tutorials

### 2.4 Elevation Shortcut

1. Type ELEV at the command prompt.  
Command: ELEV  
Specify new default elevation: <1.0000>: 2  
Specify new default thickness: <3.0000>: .5
2. Draw a new line in the left view to see the elevation and thickness settings.

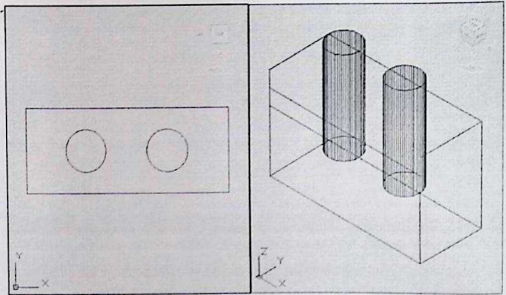

**AutoCAD 3D – Chapter 3  
Visualizing Your Model**

## AutoCAD 3D Tutorials

### 3.1 HIDE Command

Regenerates a three-dimensional model with hidden lines

1. Open a drawing with 3D objects and display in a 3D view.
2. Choose **View, Hide.**  
or
3. Type **HIDE** at the command prompt.  
Command: **HIDE**

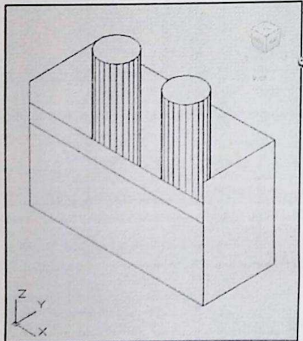

## AutoCAD 3D Tutorials

---

### 3.2 Visual Styles

A visual style is a collection of settings that control the display of edges and shading in the viewport.

Open a drawing with 3D objects and display in a 3D view.  
Choose View, Visual Styles and one of the following style options

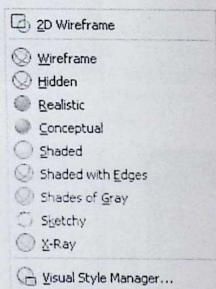

## AutoCAD 3D Tutorials

### Visual Styles

2D Wireframe

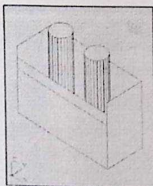

3D Wireframe

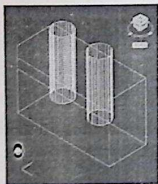

3D Hidden

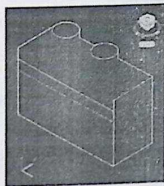

Realistic

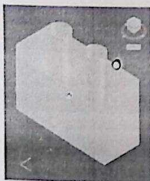

Shaded



Shaded with Edges

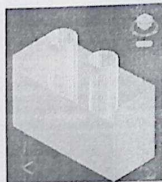

Shades of Gray



Sketchy

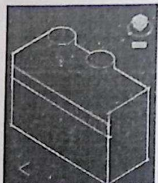

XRay

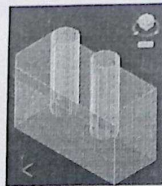

## AutoCAD 3D Tutorials

### 3.3 Visual Style Manager

The Visual Styles Manager displays sample images of the visual styles available in the drawing. The selected visual style is indicated by a yellow border, and its settings are displayed in the panel below the sample images.

1. Choose **View, Visual Styles, Visual Styles Manager...**  
or
2. Type **VISUALSTYLES** at the command prompt.  
Command: **VISUALSTYLES**
3. Choose the desired option from one of those available in the drawing for 2D Wireframe, 3D Wireframe, 3D Hidden, Realistic, or Conceptual options

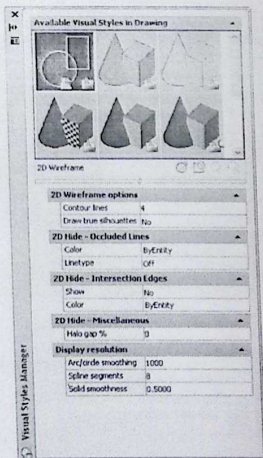

## AutoCAD 3D Tutorials

### 3.4 Visual Styles Panel

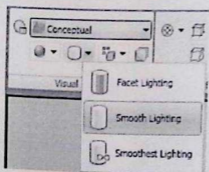
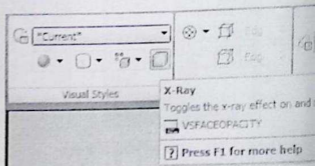
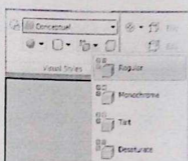
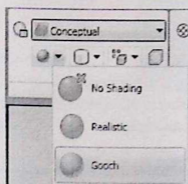
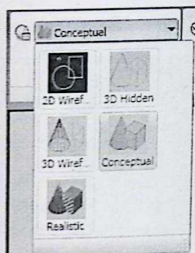
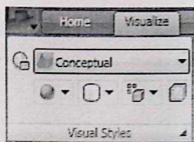

## AutoCAD 3D Tutorials

### 3.5 Adaptive 3D Grid

When you choose a shaded or 3D wireframe visual style, the grid changes from a dotted grid to a rectangular grid. The new grid provides a better sense of a model's orientation in 3D. The rectangular grid supports perspective, can display major and minor grid lines, provides color options, and can automatically control the grid density when zooming in or out (adaptive grid.) You can change the grid settings using the drafting settings dialog box.

1. Choose **Tools, Drafting Settings, and the Snap and Grid TAB.**
2. Type **DSETTINGS** at the command prompt.  
Command: **DSETTINGS**

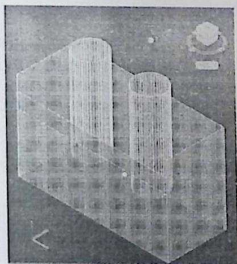
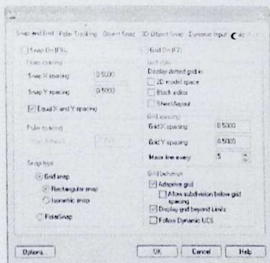

#### TIP:

You can turn the adaptive grid on/off from the status bar.



**AutoCAD 3D – Chapter 4**  
**Z Coordinates**

## AutoCAD 3D Tutorials

---

### 4.1 3D Coordinates

Entering 3D Cartesian coordinates (X,Y,Z) is similar to entering 2D coordinates (X,Y). In addition to specifying X and Y values, you specify a Z value.

1. Open a drawing with 3D objects and display in a 3D view.
2. Type 3DPoly at the command prompt.  
Command: **3DPOLY**  
Specify start point of polyline: **1,1,0**  
Specify endpoint of line or [Undo]: **1,2,1**  
Specify endpoint of line or [Undo]: **2,2,1**  
Specify endpoint of line or [Close/Undo]: **2,1,0**  
Specify endpoint of line or [Close/Undo]: **1,1,0**

The result will be the following lines that are drawn in 3D

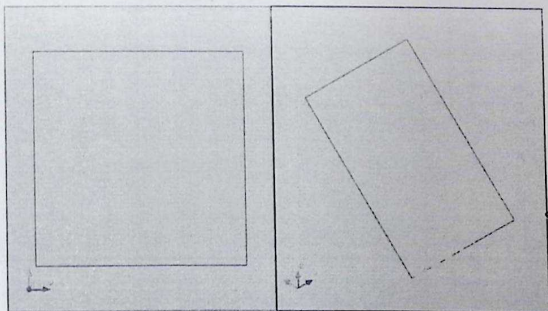

## AutoCAD 3D Tutorials

---

### 4.2 Track in Z Direction

With AutoTrack (polar tracking and object snap tracking), you can track in the Z direction as well as in the XY plane. Similarly, when Ortho mode is turned on, you can lock the cursor to the Z direction.

1. Press **F11** or click **OSnap Tracking** on the status bar if it is not already on.
2. Press **F10** or click **Polar Tracking** on the status bar if it is not already on.
3. Draw a line in the 3D view in the Z direction using tracking.

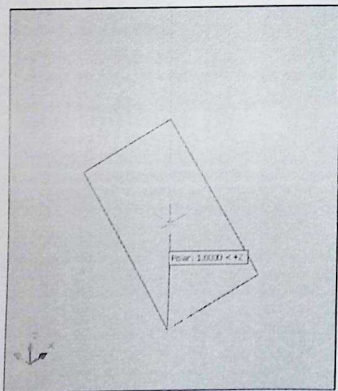

## AutoCAD 3D Tutorials

---

### 4.3 Move in Z Direction

1. Open a drawing with 3D objects in it.
2. Type **MOVE** at the command prompt.  
Command: **move**  
Select objects: pick object in 3D view  
Select objects: **press enter**  
Specify base point or displacement:  
Specify second point of displacement or  
<use first point as displacement>: 0,0,1 or use polar tracking to move the object.

before move

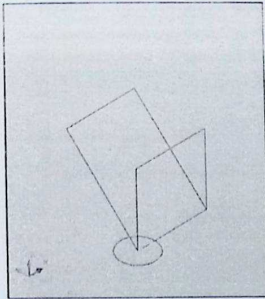

after move

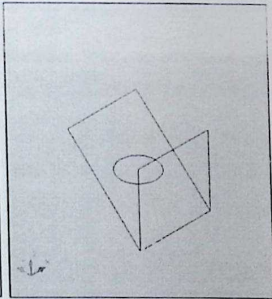

## AutoCAD 3D Tutorials

### 4.4 3D Point Filters

Draws in 3D Z direction by filtering X and Y coordinates.

1. Open a drawing with 3D objects in it.

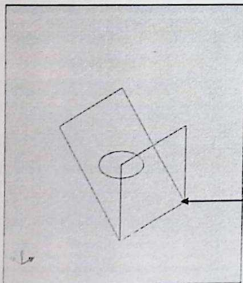

Use the CIRCLE command and place it using 3D point filters (.xy)

Command: CIRCLE

Specify center point for circle or [3P/2P/Tr (tan tan radius)]: .XY

of pick endpoint to filter

(need Z): 1

Specify radius of circle or [Diameter] <0.2500>:

press enter

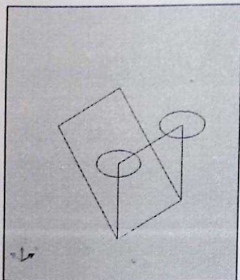

## AutoCAD 3D Tutorials

---

### 4.5 Helix

Creates a 2D or 3D spiral.

1. Begin a new drawing.
2. Choose **Draw, Helix.**  
or
3. Type **HELIX** at the command prompt.  
Command: **helix**  
Number of turns = 3.0000 Twist=CCW  
Specify center point of base: **pick point**  
Specify base radius or [Diameter] <1.0000>:  
enter or drag and pick  
Specify top radius or [Diameter] <11.0776>:  
enter or drag and pick  
Specify helix height or [Axis endpoint/Turns/turn  
Height/Wt/st] <1.0000>:  
enter or drag and pick

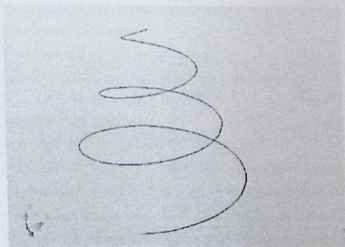

**AutoCAD 3D – Chapter 5  
User Coordinate System**

## AutoCAD 3D Tutorials

### 5.1 UCS Icon

The UCS icon represents the orientation of the user coordinate system (UCS) axes and the location of the current UCS origin. It also represents the current viewing direction relative to the XY plane. AutoCAD displays the UCS icon differently for 2D, 3D and Paper Space environments.

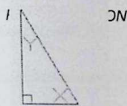
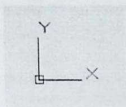
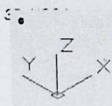

1. Choose View, Display, UCS Icon.  
or
2. Type UCSICON at the command prompt.  
Command: **ucsicon**  
Enter an option  
[ON/OFF/All/Noorigin/ORigin/Properties] <ON>:  
  
ON Displays the UCS icon.  
OFF Turns off the display of the UCSICON.  
All Affects the display of the UCSICON in all viewports.  
Noorigin Always displays the UCS at the lower left corner.  
Origin Shows the UCS at the 0,0,0 origin of the current UCS.  
Properties Changes the display properties of the UCS icon(s).

## AutoCAD 3D Tutorials

### UCS Icon Properties

1. Choose **View, Display, UCS Icon, Properties.**  
or
1. Type UCSICON at the command prompt.  
Command: **ucsicon**  
Enter an option  
[ON/OFF/All/Noorigin/ORigin/Properties] <ON>: **P**

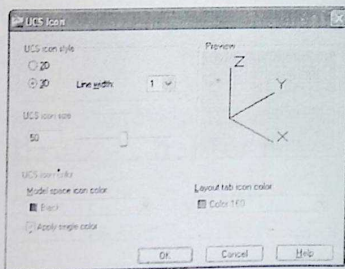

## AutoCAD 3D Tutorials

---

### 5.2 UCS Overview

The user coordinate system provides an alternate movable coordinate system for coordinate entry, planes of operation, and viewing. Most AutoCAD geometric editing commands are dependent on the location and orientation of the UCS. There are a variety of ways to set the User Coordinate System using the UCS command.

- |          |   |
|----------|---|
| 1. Type  | UCS at the command prompt   |
|          | Command: <b>UCS</b>   |
|          | Specify origin of UCS or<br>[Face/NAmed/OBJect/Previous/View/World/X/Y/Z/<br>ZAxis] <World>:                          |
| Face     | Aligns the UCS to the selected face of a solid object.  |
| Named    | Saves or restores a UCS.  |
| Object   | Lets you define a new UCS by pointing at an object.   |
| Previous | Restores the previous UCS.  |
| New      | Defines a new coordinate system by one of six<br>methods: Origin, Z Axis, 3 Point, Object,<br>Face, View X, Y, Z      |
| View     | Establishes a new UCS whose XY plane is<br>perpendicular to your viewing direction (e.g. parallel to<br>your screen). |
| World    | Restores the world UCS  |
| X/Y/Z    | Rotates the ucs around a specified axis   |

#### UCS Toolbars

Found under the AutoCAD Classic Toolbars

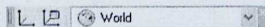
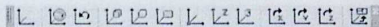

## AutoCAD 3D Tutorials

### 5.3 New (3 Point) UCS

The 3 Point option is one of the easiest ways to define a new UCS on a given 3D object.

1. Open a drawing with a simple 3D object (e.g. 3D box)
2. Type UCS at the command prompt.

Command: UCS

Specify origin of UCS or

[Face/NAmed/OBject/Previous/View/World/X/Y/Z

/ZAxis] <World>:N

Specify origin of new UCS or

[ZAxis/3point/OBject/ Face/View/X/Y/Z]

<0,0,0>: 3

Specify new origin point <0,0,0>: pick origin

Specify point on positive portion of X-axis

<3.53,7.73,0.00>: pick point for X direction

Specify point on positive-Y portion of the UCS XY plane

<2.53,8.73,0.00>: pick point for Y direction

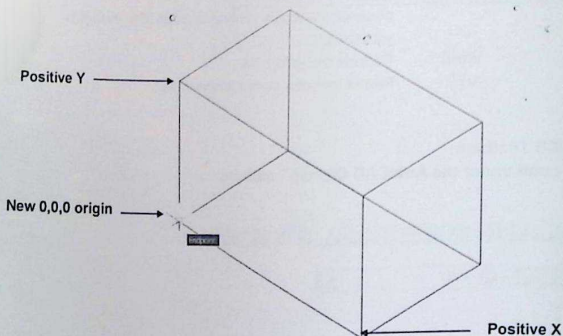

## AutoCAD 3D Tutorials

---

### New UCS

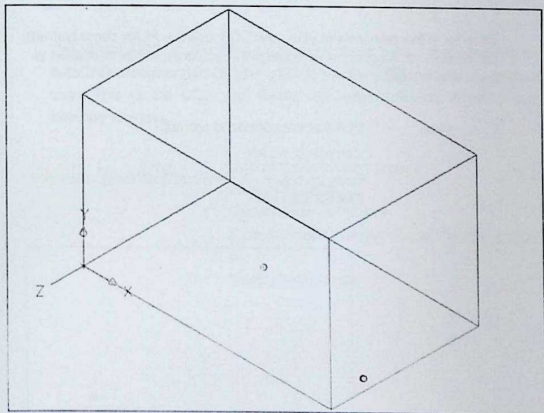

#### TIP:

You can also click the dropdown beside WCS and click New UCS.

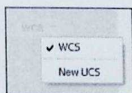

## AutoCAD 3D Tutorials

---

### 5.4 Plan UCS

To work in the plan view of your new UCS, use the PLAN command with the current UCS option. New entities that you draw will be in relation to this current UCS.

1. Type `PLAN` at the command prompt.  
Command: `PLAN`  
Enter an option [Current ucs/Ucs/World] <Current>:  
`PRESS ENTER`

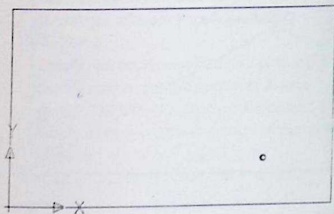

## AutoCAD 3D Tutorials

---

### 5.5 World UCS

The World UCS is the only UCS guaranteed to be the same in all AutoCAD drawings and can be used to set the UCS back to its original state. This is the UCS you should use when creating Wblocks and inserting Wblocks.

1. Type UCS at the command prompt.  
Command: UCS  
Specify origin of UCS or  
[Face/NAmed/OBject/Previous/View/World/X/Y  
/ZAxis] <World>.W

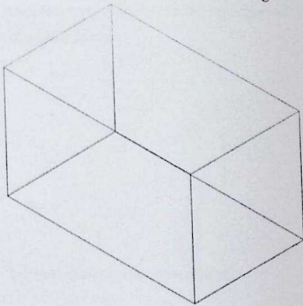

## AutoCAD 3D Tutorials

---

### 5.6 View UCS

Establishes a new coordinate system whose XY plane is perpendicular to your viewing direction (i.e. parallel to your screen)

1. Type UCS at the command prompt.  
Command: UCS  
Specify origin of UCS or  
[Face/NAmed/OBject/Previous/View/World/X/Y  
/Z/ZAxis] <World>:V

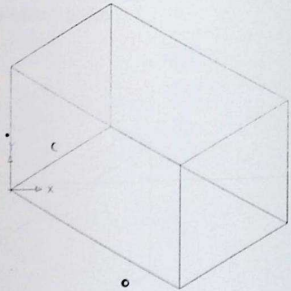

## AutoCAD 3D Tutorials

### 5.7 Dynamic UCS

You can use the dynamic UCS to create objects on a planar face of a 3D solid without manually changing the UCS orientation.

During a command, the dynamic UCS temporarily aligns the XY plane of the UCS with a planar face of a 3D solid when you move the cursor over the face.

When the dynamic UCS is active, specified points, and drawing tools, such as polar tracking and the grid, are all relative to the temporary UCS established by the dynamic UCS. 1.

1. Click the DUCS icon  on the status bar  
or
2. Press **CTRL +D**.
3. Type any draw command.  
Command: **CIRCLE**
4. Move the cursor to the face of the 3D object on which you would like to draw.

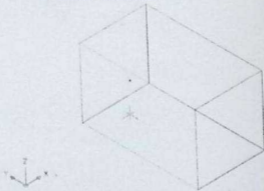

5. Click  to begin drawing your new object.

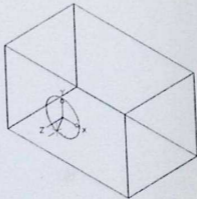

## AutoCAD 3D Tutorials

---

### 5.8 Naming a UCS

User coordinate systems can sometimes be complicated and it is often useful to name and save them so you can quickly recall them.

1. Type UCS at the command prompt.  
Command: **UCS**  
Specify origin of UCS or  
[Face/NAmed/OBject/Previous/View/World/XY/Z  
/ZAxis] <World>**NA**  
Enter an option [Restore/Save/Delete/?]: **S**  
Enter name to save current UCS or [?]: **LeftSide**

## AutoCAD 3D Tutorials

---

### 5.9 Restoring a UCS

A named and saved UCS can be restored at any time.

1. Type UCS at the command prompt.  
Command: UCS  
Specify origin of UCS or  
[Face/NAmed/OBject/Previous/View/World/XYZ/  
/ZAxis] <World>NA  
Enter an option [Restore/Save/Delete/?]: R  
Enter name to save current UCS or [?]: LeftSide

## AutoCAD 3D Tutorials

---

### 5.10 UCS Dialog Box

Displays and modifies defined and unnamed user coordinate systems, restores named and orthographic UCSs, and specifies UCS icon and UCS settings for viewports via a dialog box.

1. Chose Tools, Named UCS.  
or
2. Type UCSMAN at the command prompt.  
Command: **UCSMAN**

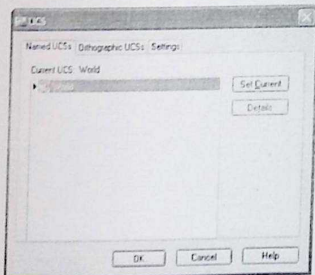

## AutoCAD 3D Tutorials

---

### 5.10 Viewcube

The ViewCube provides visual feedback about the current orientation of a model. The ViewCube can help you adjust the viewpoint of a model. The orientation shown by the ViewCube is based on the North direction of the WCS for the model. The ViewCube also shows the current UCS and allows you to restore a named UCS.

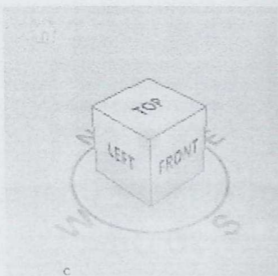

**AutoCAD 3D – Chapter 6**  
**3D Orbit**

## AutoCAD 3D Tutorials

---

### 6.1 Constrained 3D Orbit

3DORBIT activates a 3D Orbit view in the current viewport. You can view your entire drawing or select one or more objects before starting the command.

When 3DORBIT is active, the target of the view stays stationary and the camera location, or point of view, moves around the target. However, from the user's point of view, it appears as if the 3D model is turning as the mouse cursor is dragged. In this way, you can specify any view of the model.

1. Open a drawing with 3D objects.
2. Choose View, Orbit, Constrained Orbit.  
or
3. Type 3D Orbit at the command prompt.  
Command: 3DOrbit
4. Click and drag to move your object in 3D.

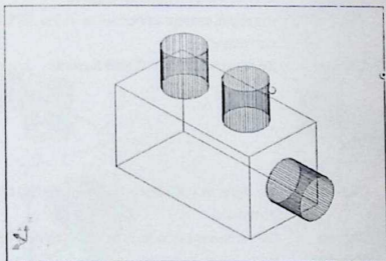

## AutoCAD 3D Tutorials

### 6.2 Zoom and Pan in 3D Orbit

#### Zoom

1. Click the **right mouse button** while in the 3D Orbit command.

2. Choose **Zoom Window** from the pop-up menu.

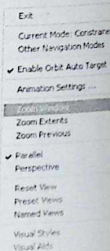

3. Zoom to a new area of the 3D drawing.

4. Click the **right mouse button** while in the 3D Orbit command.

5. Choose **Zoom Previous** or **Zoom Extents**.

#### Pan

1. Click the **right mouse button** while in the 3D Orbit command.

2. Choose **Other Navigation Modes** from the pop-up menu.

3. Choose **Pan**.

4. Pan to a new area of the drawing.

5. Click the **right mouse button** while in the 3D Orbit command.

6. Choose **Other Navigation Modes** from the pop-up menu.

7. Choose **Constrained Orbit** to set the mode back to orbit.

## AutoCAD 3D Tutorials

---

### 6.3 Projection Mode

1. Click the **right mouse button** while in the 3D Orbit command.
2. Choose **Perspective**.

Perspective view displays objects in perspective so that all parallel lines converge at one point. Objects appear to recede into the distance, and parts of the objects appear larger and closer to you. The shapes are somewhat distorted when the object is very close. This view correlates more closely to what your eye sees.

Parallel view displays objects so that two parallel lines in a drawing never converge at a single point. The shapes in your drawing always remain the same and do not appear distorted when they are closer.

Perspective View

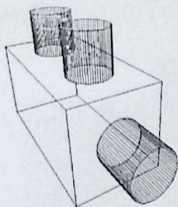

Parallel View

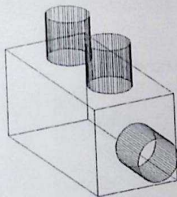

## AutoCAD 3D Tutorials

### 6.4 Visual Styles

Displays your objects in one of the following selected styles:

1. Click the **right mouse** button while in the 3D Orbit command
2. Choose **Visual Styles** from the pop-up menu.
3. Choose one of the Visual Styles.

#### Visual Style Examples

3D Hidden



3D Wireframe

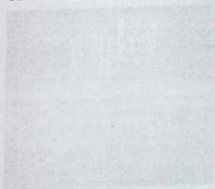

Conceptual

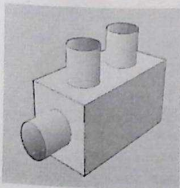

Realistic

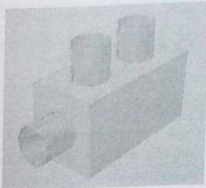

## AutoCAD 3D Tutorials

---

### 6.5 Visual Aids

1. Click the **right mouse button** while in the 3D Orbit command.
2. Choose **Visual Aids** from the pop-up menu.
3. Choose **Compass, Grid, or UCS Icon**

Compass

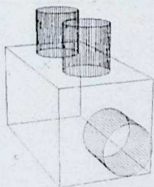

Grid

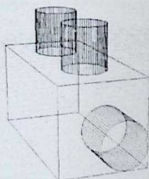

UCS Icon

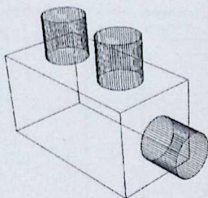

## AutoCAD 3D Tutorials

### 6.6 Preset Views

Sets the 3D view while in the orbit command

1. - Click the **right mouse** button while in the 3D Orbit command.
2. Choose **Preset Views** from the pop-up menu.
3. Choose one of the following standard 3D views.

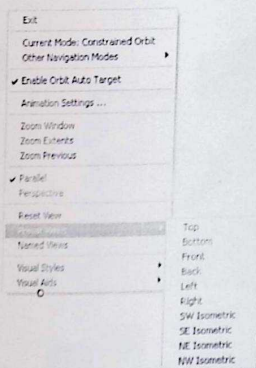

## AutoCAD 3D Tutorials

### 6.7 Free Orbit

1. Choose **View, Orbit, Free Orbit**.  
The 3D Orbit Arcball appears.
2. Click one of the 3D Orbit Arcball locations to move the display of your object(s).

*Outside the Arcball - Moves View about an axis that extends through the center (acts like twist)*

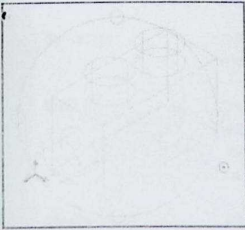

*Inside one of the small circles to the left/right - Rotates around the "Y" axis through the center.*

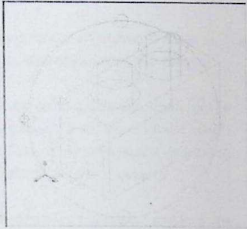

*Inside the Arcball - Allows movement in any direction*

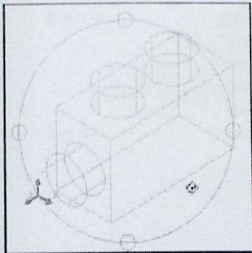

*Inside one of the small circles to the top/bottom - Rotates around the "X" axis through the center.*

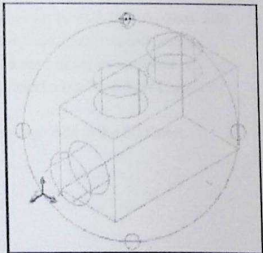

## AutoCAD 3D Tutorials

---

### 6.8 Continuous Orbit

1. Choose **View, Orbit, Continuous Orbit.**
2. Click and drag to define the direction and speed of a continuous orbit for your object(s).
3. Press **ESC** on the keyboard to stop the orbit.

## AutoCAD 3D Tutorials

---

### 6.9 Other Navigational Modes

1. Click the **right mouse** button while in the 3D Orbit command.
2. Choose **Other Navigational Modes** from the pop-up menu.
3. Choose one of the following modes.

- Adjust Distance (4)** Simulates moving the camera closer to the object or farther away.
- Swivel (5)** Changes the cursor to an arched arrow and simulates the effect of swiveling the camera.
- Walk (6)** Changes the cursor to a plus sign and enables you to "walk through" a model at a fixed height above the XY plane, by dynamically controlling the location and target of the camera.
- Fly (7)** Changes the cursor to a plus sign and enables you to "fly through" a model without being restricted to a fixed height above the XY plane.
- Zoom (8)** Changes the cursor to a magnifying glass with plus (+) and minus (-) sign and simulates moving the camera closer to an object or farther away. Works like the Adjust Distance option.
- Pan (9)** Pans the drawing while in the 3D Orbit.

**AutoCAD 3D – Chapter 7**  
**3D Navigation**

## AutoCAD 3D Tutorials

---

### 7.1 Creating a Camera

Sets a camera and target location to create and save a 3D perspective view of objects.

1. Open a drawing with 3D objects.
2. Choose View, Create Camera.  
or
3. Type CAMERA at the command prompt.

Command: **CAMERA**

Current camera settings: Height=0.0000 Lens  
Length=50.0000 mm

Specify camera location: **.XY**  
of (need Z): **7**

Specify target location: **endp**

Enter an option

[?/Name/Location/Height/Target/Lens/Clipping/View/eXit]<eXit>: X

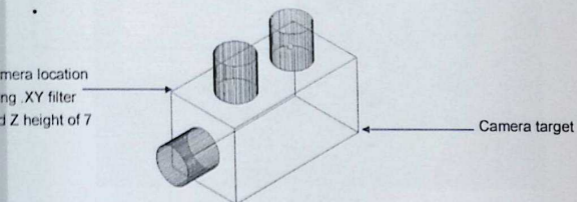

## AutoCAD 3D Tutorials

### 7.2 Viewing a Camera

Once a camera is created, it becomes a named view in the drawing and can be viewed using the Named View Manager. You can also view the camera using the view option when creating the camera.

1. Choose **View, 3D Views, Southwest Isometric** to be sure you are not in an existing camera view.
2. Choose **View, Named Views**.
3. Click the plus (+) sign beside **Model Views**.
4. Click **Camera1, Set Current, Apply, and OK**.

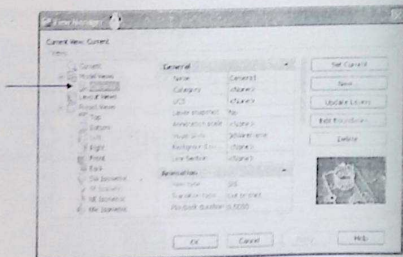

View from Camera

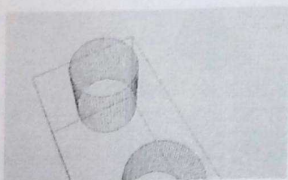

## AutoCAD 3D Tutorials

---

### 7.3 Camera Preview

Camera preview is a quick and easy way to see the properties of a camera before viewing from the camera.

1. Choose View, 3D Views, Southwest Isometric to be sure you are not in an existing camera view.
2. Zoom out until you see the camera in your 3D view.
3. Click once on a camera in your view.

The Camera Preview dialog box will show the view from the chosen camera. You can change the Visual style of this preview by clicking the Visual Style dropdown.

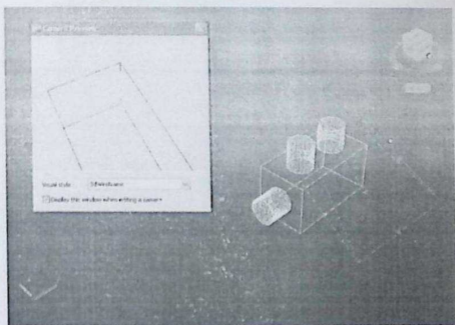

## AutoCAD 3D Tutorials

### 7.4 Camera Properties

1. Double click a camera in a 3D isometric view,
2. Choose one of the following properties to change.

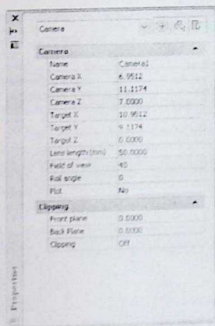

## AutoCAD 3D Tutorials

### 7.5 Displaying and Plotting a Camera

#### Displaying a Camera

1. Choose **View, Display, Cameras**.

#### Plotting a Camera

1. Click **View, Display, Cameras**.
2. Double-click a camera.
3. Click **Yes** under the Plot option.

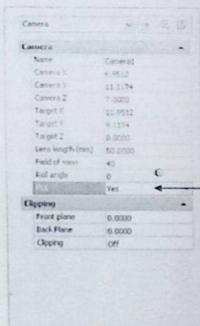

## AutoCAD 3D Tutorials

### 7.6 Adjusting Camera Distances and Swiveling a Camera

#### *Adjust Camera Distance*

1. Choose View, Named Views.
2. Click the plus (+) sign beside Model Views.
3. Click Camera1, Set Current, Apply, and OK.
4. Choose View, Camera, Adjust Distance.
5. Click and drag to zoom in or out about the camera.

#### *Swivel a Camera*

1. Choose View, Camera, Swivel.
2. Click and drag to swivel the camera.

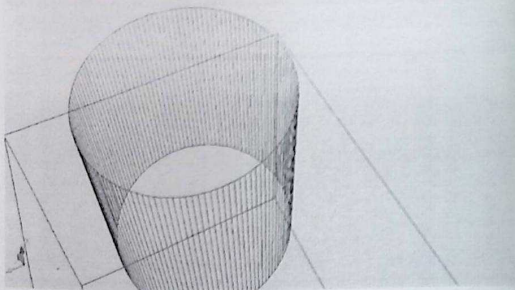

## AutoCAD 3D Tutorials

### 7.7 DView Command

Defines parallel projection or perspective views by using a camera and target.

1. Choose View, 3D Views, SW Isometric.
2. Type DVIEW at the command prompt.  
Command: DVIEW  
Select objects or <use DVIEWBLOCK>: pick objects and press ENTER  
Enter option  
[CAmera/TArget/Distance/POints/PAn/Zoom/TWist/CLip/Hide/Off/Undo]: PO  
Specify target point <3.2567, 4.0405, 7.299>:  
pick target (see below)  
Specify camera point <-4.0520, -3.2436, 14.3538>:  
.XY  
of (need Z): 7  
Enter option  
[CAmera/TArget/Distance/POints/PAn/Zoom/TWist/CLip/Hide/Off/Undo]: D  
Specify new camera-target distance <8.3066>:  
click and drag new zoom  
Enter option  
[CAmera/TArget/Distance/POints/PAn/Zoom/TWist/CLip/Hide/Off/Undo]:  
Regenerating model.

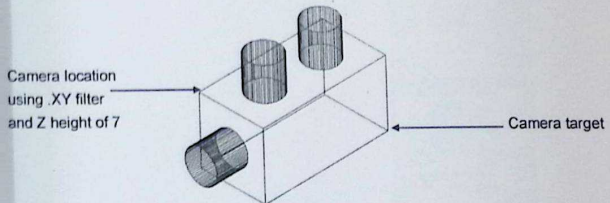

## AutoCAD 3D Tutorials

---

New perspective view

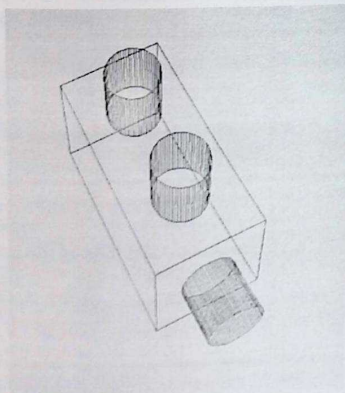

## AutoCAD 3D Tutorials

### 7.8 Walk and Fly

You can simulate walking and flying through a 3D drawing.

When you walk through a model, you travel along the XY plane. When you fly through a model, you are not constrained by the XY plane, so you appear to "fly" over an area in a model.

The following shortcuts are available for walking:

Up arrow / W key	Move forward
Down arrow / S key	Move backward
Left arrow / A key	Move left
Right arrow / D key	Move right
Drag mouse	Look around & turn

1. Open a drawing with 3D objects and display in a 3D view.
2. Create a camera anywhere in the drawing and set the view to that camera.
3. Choose View, Walk and Fly, and Walk  
or  
4. Type 3DWalk or 3DFly at the command prompt.  
Command: 3DWALK

The following Position Locator dialog box will appear that you can use to navigate your drawing.

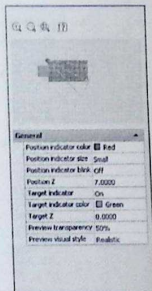

## AutoCAD 3D Tutorials

5. Press the **Up, Down, Left, and Right** keys on the keyboard to see how the camera location moves in the drawing and Position Locator dialog box.
6. Move the camera and target in the Position Locator dialog box.
7. Click and drag your mouse to "fly" through the drawing.

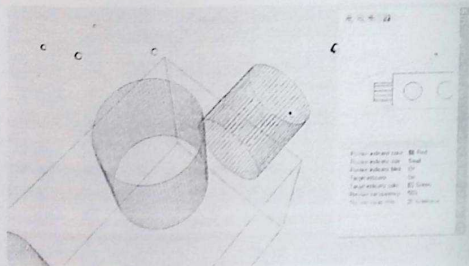

8. Close the Position Locator dialog box and try walking and flying using only the keys on the keyboard and mouse.

## AutoCAD 3D Tutorials

---

### 7.9 Walk and Fly Settings

1. Choose View, Walk and Hide, Walk and Hide Settings, or
2. Type WALKFLYSETTINGS at the command prompt  
Command: WALKFLYSETTINGS
3. Choose one of the following settings from the Walk and Fly dialog box.

If you are working in a drawing with a large architectural scale, be sure to set your drawing units to a large number, similar to the scale of the drawing.

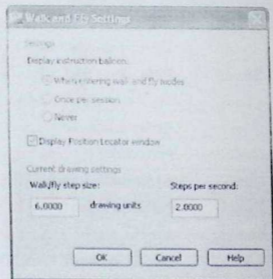



## AutoCAD 3D Tutorials

### 7.10 Animation Paths

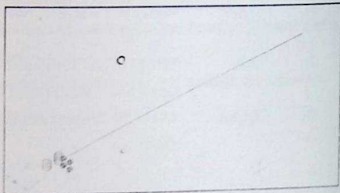
1. Open a drawing with 3D objects and display in a 3D view.
2. Draw a line or polyline representing a path for an animation



3. Choose **View, Motion Path Animations**.  
or
4. Type **ANIPATH** at the command prompt.  
Command: **ANIPATH**
5. Select **Path** under the **Link camera to:** option 
6. Click the line or polyline path.
7. Type **Path1** as the default path name.
8. Select **Path** under the **Link target to:** option 
9. Click on the line or polyline path.
10. Type **Path2** as the default path name.
11. Change other animation settings such as the frames per second, duration, resolution, etc.

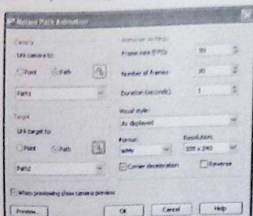

## AutoCAD 3D Tutorials

12. Choose the Preview... button to preview your animation.

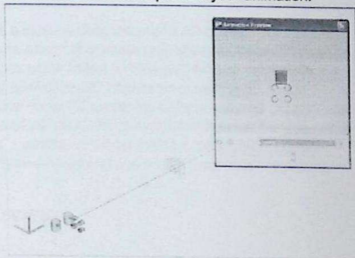

13. Close the animation preview and click OK to create an animation file.

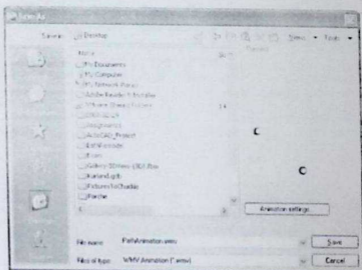

14. Play your animation in a PC or Macintosh video review application such as Media Player or Quicktime.

AutoCAD 3D – Chapter 8  
3D Model Objects

## AutoCAD 3D Tutorials

---

### 8.1 Wireframes

A wireframe model is a skeletal description of a 3D object. There are no surfaces in a wireframe model; it consists only of points, lines, and curves that describe the edges of the object. With AutoCAD you can create wireframe models by positioning 2D objects anywhere in 3D space. AutoCAD also provides some 3D wireframe objects, such as 3D polylines (that can only have a CONTINUOUS linetype) and splines. Because each object that makes up a wireframe model must be independently drawn and positioned, this type of modeling can be the most time-consuming.

Wireframe lines in 3D

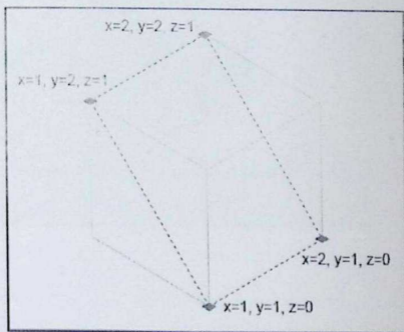

## AutoCAD 3D Tutorials

---

### 8.2 Surfaces

Surface modeling is more sophisticated than wireframe modeling in that it defines not only the edges of a 3D object, but also its surfaces. The AutoCAD surface modeler defines faceted surfaces using a polygonal mesh. Because the faces of the mesh are planar, the mesh can only approximate curved surfaces.

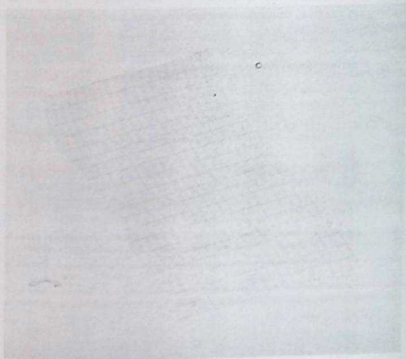

## AutoCAD 3D Tutorials

---

### 8.3 Solids

Solid modeling is the easiest type of 3D modeling to use. With the AutoCAD solid modeler, you can make 3D objects by creating basic 3D shapes: boxes, cones, cylinders, spheres, wedges, and tori (do-nuts). You can then combine these shapes to create more complex solids by joining or subtracting them or finding their intersecting (over-lapping) volume. You can also create solids by sweeping a 2D object along a path or revolving it about an axis.

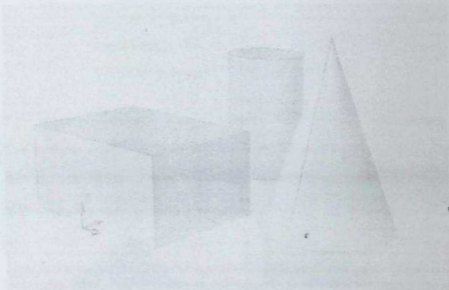

**AutoCAD 3D – Chapter 9  
2D Solids and 3D Faces**

## AutoCAD 3D Tutorials

---

### 9.1 2D Solid

Creates solid-filled triangles and quadrilaterals.

1. Type SOLID at the command prompt.  
Command: SOLID  
First point: P1  
Second point: P2  
Third point: P3  
Fourth point: P4  
Third point: enter

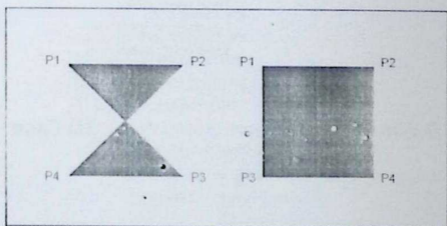

## AutoCAD 3D Tutorials

### 9.2 3D Faces

3DFACE creates a three or four sided surface anywhere in 3D space. You can specify different Z coordinates for each corner point of a 3D face. 3DFACE differs from SOLID, which creates a three- or four-sided surface that is parallel to the current UCS and can be extruded.

1. Begin a new drawing.
2. Set the visual style to Conceptual.
3. Type 3DFACE at the command prompt.

Command: 3DFACE

First point: pick

Second point: pick

Third point: pick

Fourth point: pick

Third point: enter

3D Wireframe Lines

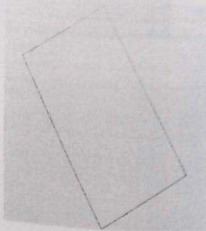

3D Face

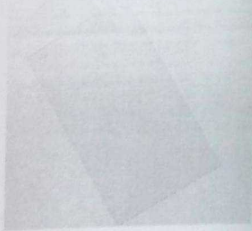

## AutoCAD 3D Tutorials

### 9.3 3D Face Invisible Edge

With 3DFACE, you control which edges of a 3D face are visible, allowing accurate modeling of objects with holes. Entering *i* or *invisible* before the first point of an edge makes the edge invisible. Type 3DFACE at the command prompt.

1. Draw an irregular shaped object similar to the one shown below.
2. Set the visual style to Conceptual.
3. Type 3DFACE at the command prompt.

• Command: 3DFACE

First point: P1

Second point: P2

Third point: *i* P3

Fourth point: P4

Third point: *i* P5

Fourth point: P6

Third point: P7

Fourth point: P8

Third point: enter

NOTE: You must enter an "i" for invisible before the face is chosen.

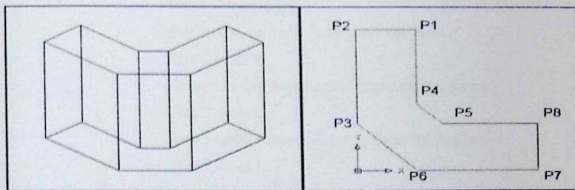

## AutoCAD 3D Tutorials

### 9.4 Edge Command

1. Type EDGE at the command prompt.

Command: EDGE

Specify edge of 3dface to toggle visibility or [Display]:  
pick edge

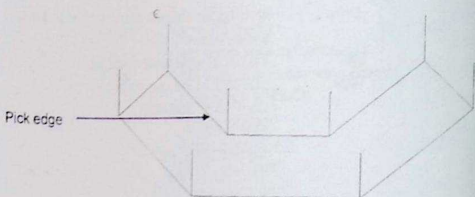

Specify edge of 3dface to toggle visibility or [Display]:  
D

Enter selection method for display of hidden edges  
[Select/All] <A!> A

\*\* Regenerating 3DFACE objects... done.

Specify edge of 3dface to toggle visibility or [Display]:  
press enter

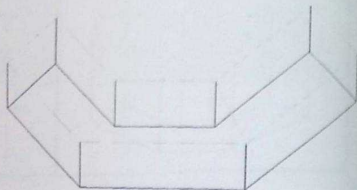

## AutoCAD 3D Tutorials

---

### 9.5 PFace

Creates a three-dimensional polyface mesh vertex by vertex

#### 1. Type

PFACE at the command prompt

Command: PFACE

Specify location for vertex 1: pick point 1

Specify location for vertex 2 or <define faces>: pick point 2

Specify location for vertex 3 or <define faces>: pick point 3

Specify location for vertex 4 or <define faces>: pick point 4

Specify location for vertex 5 or <define faces>: pick point 5

Specify location for vertex 6 or <define faces>: pick point 6

Specify location for vertex 7 or <define faces>: pick point 7

Specify location for vertex 8 or <define faces>: enter

Face 1, vertex 1:

Enter a vertex number or [Color/Layer]: 1 (enter)

Face 1, vertex 2:

Enter a vertex number or [Color/Layer] <next face>: 2 (enter)

Face 1, vertex 3:

Enter a vertex number or [Color/Layer] <next face>: 6 (enter)

Face 1, vertex 4:

Enter a vertex number or [Color/Layer] <next face>: 7 (enter)

Face 1, vertex 5: enter

Enter a vertex number or [Color/Layer] <next face>:

Face 2, vertex 1:

Enter a vertex number or [Color/Layer]: 2 (enter)

Face 2, vertex 2:

Enter a vertex number or [Color/Layer] <next face>: 3 (enter)

Face 2, vertex 3:

Enter a vertex number or [Color/Layer] <next face>: 4 (enter)

Face 2, vertex 4:

## AutoCAD 3D Tutorials

Enter a vertex number or [Color/Layer] <next face>: **6 (enter)**

Face 2, vertex 5:

Enter a vertex number or [Color/Layer] <next face>:

Face 3, vertex 1:

Enter a vertex number or [Color/Layer]: **4 (enter)**

Face 3, vertex 2:

Enter a vertex number or [Color/Layer] <next face>: **5 (enter)**

Face 3, vertex 3:

Enter a vertex number or [Color/Layer] <next face>: **6 (enter)**

Face 3, vertex 4:

Enter a vertex number or [Color/Layer] <next face>:

Face 4, vertex 1: **enter**

Enter a vertex number or [Color/Layer]:

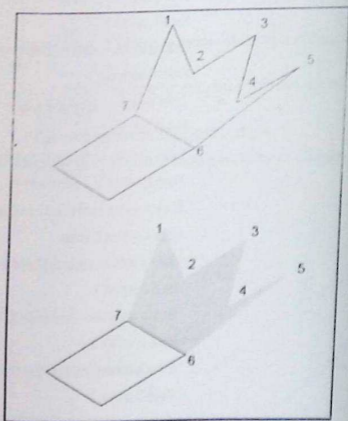

**AutoCAD 3D – Chapter 10**  
**Basic 3D Surfaces**

## AutoCAD 3D Tutorials

### 10.1 Basic Mesh Commands

1. Click the 3D Modeling dropdown option from the Solids panel.
2. Click the Mesh tab.
3. Click the Primitives panel.
4. Click the Primitive drop-down.

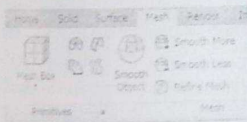

### Mesh Primitive Options

The following settings can be adjusted for mesh primitives.

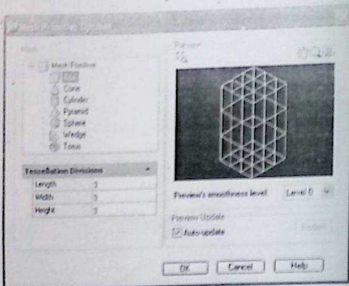

## AutoCAD 3D Tutorials

---

### Mesh Box

1. Choose Mesh box from the Primitives panel.  
Command. **MESH**  
Current smoothness level is set to : 0  
Enter an option  
[Box/Cone/Cylinder/Pyramid/Sphere/Wedge/Torus/  
SEttings] <Box>: **\_BOX**  
Specify first corner or [Center]: pick point  
Specify other corner or [Cube/Length]: **@4,2**  
Specify height or [2Point] <3.0000>: **2**

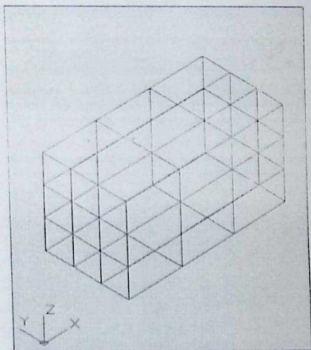

## AutoCAD 3D Tutorials

### Mesh Cone

1. Choose Mesh cone from the Primitives panel.  
Command: MESH  
Current smoothness level is set to : 0  
Enter an option  
[Box/Cone/Cylinder/Pyramid/Sphere/Wedge/Torus/Settings] <C one>: CONE  
Specify center point of base or [3P/2P/Tr/Elliptical]:  
Specify base radius or [Diameter] <1.5074>: 2  
Specify height or [2Point/Axis endpoint/Top radius] <2.0000>: 5

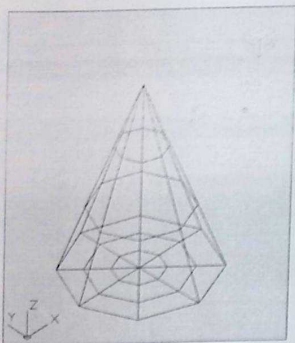

## AutoCAD 3D Tutorials

### Mesh Cylinder

1. Choose Mesh cylinder from the Primitives panel.  
Command: **MESH**  
Current smoothness level is set to : 0  
Enter an option  
[Box/Cone/Cylinder/Pyramid/Sphere/Wedge/Torus/  
SEttings]  
<Cylinder>: **CYLINDER**  
Specify center point of base or [3P/2P/Ttr/Elliptical]:  
Specify base radius or [Diameter] <2.0000>: **2**  
Specify height or [2Point/Axis endpoint] <5.0000>: **8**

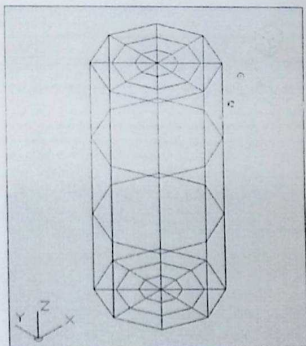

## AutoCAD 3D Tutorials

### Mesh Pyramid

1. Choose Mesh pyramid from the Primitives panel.  
Command: **MESH**  
Current smoothness level is set to : 0  
Enter an option  
[Box/Cone/Cylinder/Pyramid/Sphere/Wedge/Torus/Settings]  
<Pyramid>: **PYRAMID**  
4 sides Circumscribed  
Specify center point of base or [Edge/Sides]:  
Specify base radius or [Inscribed] <2.0000>:  
Specify height or [2Point/Axis endpoint/Top radius]  
<8.0000>: 4

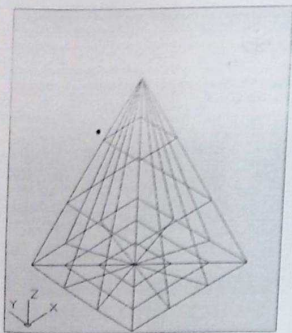

## AutoCAD 3D Tutorials

---

### Mesh Sphere

1. Choose Mesh sphere from the Primitives panel.

Command: MESH

Current smoothness level is set to : 0

Enter an option :

[Box/Cone/Cylinder/Pyramid/Sphere/Wedge/Torus/Settings]

<Pyramid>: SPHERE

Specify center point or [3P/2P/Tr]:

Specify radius or [Diameter] <2.0000>:

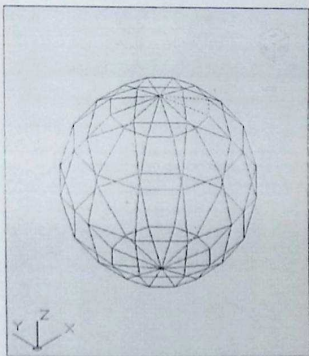

## AutoCAD 3D Tutorials

### Mesh Wedge

1. Choose Mesh wedge from the Primitives panel.

Command: **MESH**

Current smoothness level is set to : 0

Enter an option

[Box/Cone/Cylinder/Pyramid/Sphere/Wedge/Torus/S

ettings]

<Wedge>: **WEDGE**

Specify first corner or [Center]:

Specify other corner or [Cube/Length]: **@4,2**

Specify height or [2Point] **<-4.0000>: 2**

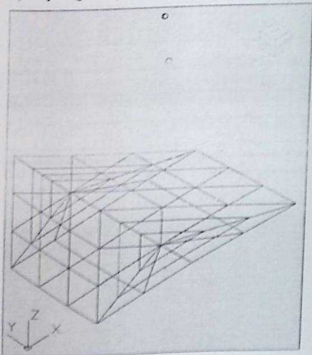

## AutoCAD 3D Tutorials

---

### Mesh Torus

1. Choose Mesh torus from the Primitives panel.  
Command: **MESH**  
Current smoothness level is set to : 0  
Enter an option  
[Box/Cone/Cylinder/Pyramid/Sphere/Wedge/Torus/Settings]  
<Wedge>: **TORUS**  
Specify center point or [3P/2P/Tr]:  
Specify radius or [Diameter] <2.0000>: 6  
Specify tube radius or [2Point/Diameter]: 1

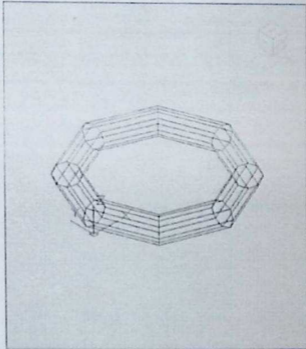

## AutoCAD 3D Tutorials

### 10.2 Mesh Tesselations

By default, new mesh primitives are created with no smoothness. To change the default smoothness, enter mesh at the Command prompt. Specify the Settings option before you specify the type of mesh primitive you want to create.

1. Type MESH at the command prompt.  
Command: MESH  
Enter an option  
[Box/Cone/Cylinder/Pyramid/Sphere/Wedge/Torus/Settings]  
<Box>: SE  
Specify level of smoothness or [Tesselation] <0>: 3  
Enter an option  
[Box/Cone/Cylinder/Pyramid/Sphere/Wedge/Torus/Settings]  
<Box>: BOX  
Specify first corner or [Center]: pick point  
Specify other corner or [CubeA.length]: @5,5  
Specify height or [ZPoint] <3.0000>:

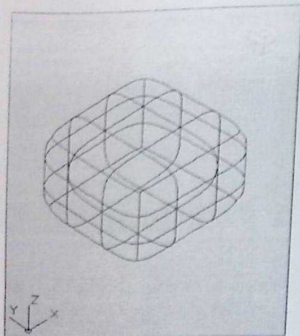

## AutoCAD 3D Tutorials

### 10.3 Mesh Smooth

Converts 3D faces (3DFACE) and legacy polygonal and polyface meshes (from AutoCAD 2009 and earlier). You can also convert 2D objects such as regions and closed polylines. The default mesh settings are defined in the Mesh Tessellation Options Dialog box. The level of smoothness upon conversion depends on the mesh type setting in this dialog box. If the mesh type is not set to be optimized, the converted object is not smoothed.

1. Type MESHSMOOTH at the command prompt.  
Command: **MESHSMOOTH**  
Select objects to convert: **pick object**  
Select objects to convert: **press enter**
2. Click Create mesh.

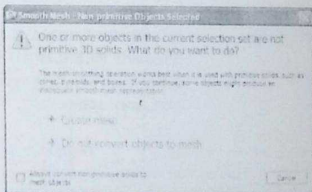

2D Polyline before MESHSMOOTH

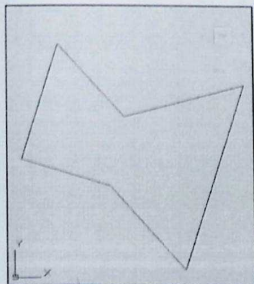

2D Polyline after MESHSMOOTH

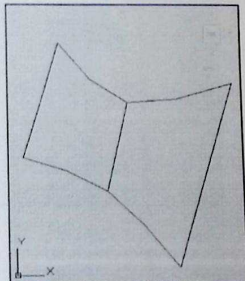

## AutoCAD 3D Tutorials

### 10.4 Smooth and Refine Meshes

The following commands control the smoothness of mesh objects.

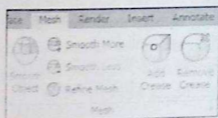

#### Meshsmoothmore

Increases the level of smoothness for mesh objects by one level.

1. Type `MESHSMOOTHMORE` at the command prompt.  
Command: `MESHSMOOTHMORE`  
Select mesh objects to increase the smoothness level: pick object

Mesh before smooth increase

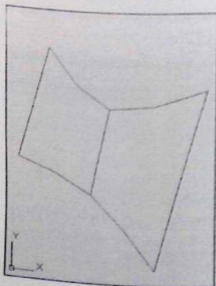

Mesh after smooth increase

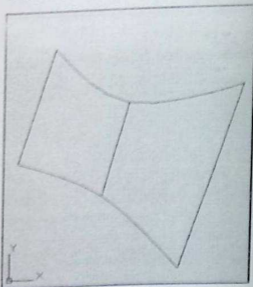

## AutoCAD 3D Tutorials

---

### Meshsmoothless

Decreases the level of smoothness for mesh objects by one level.

1. Type `MESHSMOOTHLESS` at the command prompt.  
Command: `MESHSMOOTHLESS`  
Select mesh objects to increase the smoothness level: pick object. 

Mesh before smooth decrease

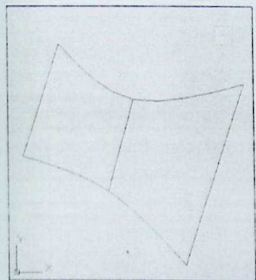

Mesh after smooth decrease

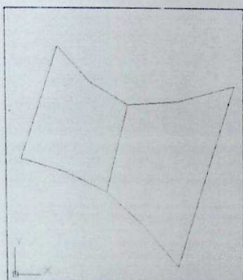

## AutoCAD 3D Tutorials

### Meshsmoothrefine

Multiplies the number of faces in selected mesh objects or faces.

1. Type MESHREFINE at the command prompt.  
Command: `_MESHREFINE`  
Select mesh object or face subobjects to refine:  
pick object  
Select mesh object or face subobjects to refine:  
1 object(s) found.

Mesh refine before

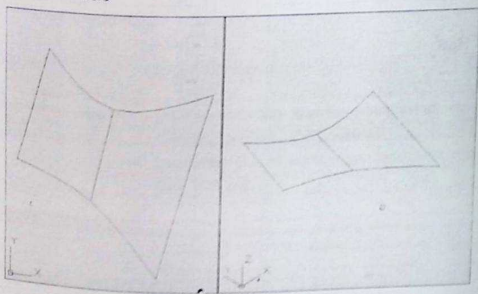

Mesh refine after

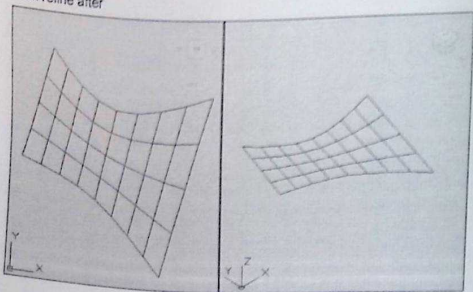

## AutoCAD 3D Tutorials

### 10.5 Add and Remove Mesh Creases

#### Meshcrease

Sharpens the edges of selected mesh subobjects.

1. Type MESHCREASE at the command prompt.  
Command: MESHCREASE  
Select mesh subobjects to crease: select objects  
Specify crease value [Always] <Always> enter

Before crease

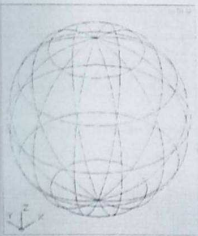

Selected objects

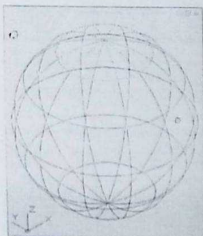

After crease

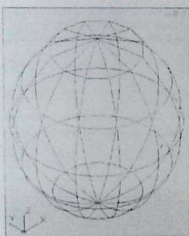

#### TIPS:

##### Crease value

Sets highest smoothing level at which the crease is retained. If the smoothing level exceeds this value, the crease is also smoothed. Enter a value of 0 to remove an existing crease.

##### Always

Specifies that the crease is always retained, even if the object or subobject is smoothed or refined. A crease value of -1 is the same as Always.

## AutoCAD 3D Tutorials

### Meshuncrease

Removes the crease from selected mesh faces, edges, or vertices.

1. Type MESHUNCREASE at the command prompt.  
Command: MESHUNCREASE  
Select crease to remove: pick object  
Select crease to remove: press enter

Before uncrease

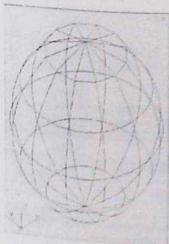

Selected objects

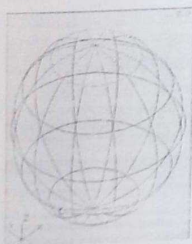

After uncrease



## AutoCAD 3D Tutorials

### 10.6 Editing Meshes

#### Meshextrude

Extends a mesh face into 3D space.

1. Type **MESH EXTRUDE** at the command prompt.  
Command: **\_MESH EXTRUDE**  
Adjacent extruded faces set to: **Join**  
Select mesh face(s) to extrude or [Setting]:  
**pick object(s)**  
Select mesh face(s) to extrude or [Setting]:  
Specify height of extrusion or [Direction/Path/  
Taper angle] <0.5000>: **1**

Selected mesh face

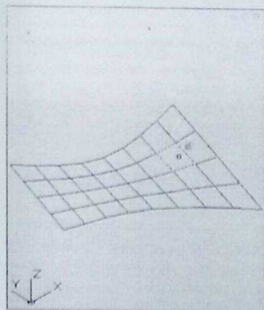

Extruded mesh face

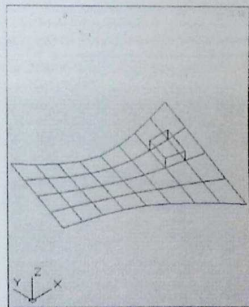

## AutoCAD 3D Tutorials

### Meshsplit

Splits a mesh face into 2 faces.

1. Type MESHSPPLIT at the command prompt.  
Command: **\_MESHSPPLIT**  
Select a mesh face to split: (pick object)

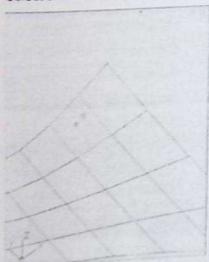

Specify first split point on face edge or [Vertex] MID of

Specify second split point on face edge or [Vertex] MID of

MIDpoint

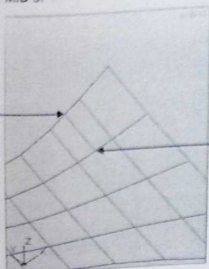

MIDpoint

## AutoCAD 3D Tutorials

---

### Mergeface

Merges adjacent faces into a single face.

1. Type MESHMERGE at the command prompt  
Command: `_MESHMERGE`  
Select adjacent mesh faces to merge: (pick object)  
Select adjacent mesh faces to merge: (pick object)  
Select adjacent mesh faces to merge: press enter

Selected mesh faces

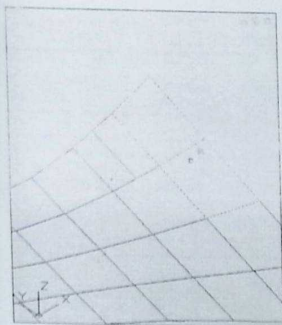

Resultant merge

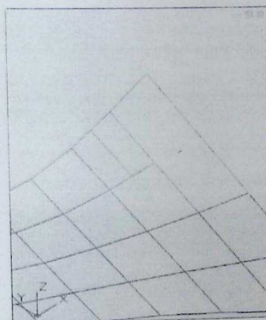

## AutoCAD 3D Tutorials

### Meshcap (Close Hole)

Creates a mesh face that connects open edges..

1. Type MESHCAP at the command prompt.  
Command: `_MESHCAP`  
Select connecting mesh edges to create a new mesh face: (pick objects)  
Select connecting mesh edges to create a new mesh face: press enter

Mesh object before

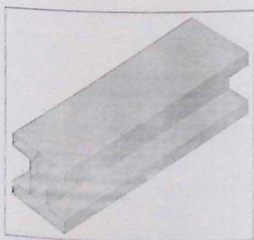

Selected mesh edges

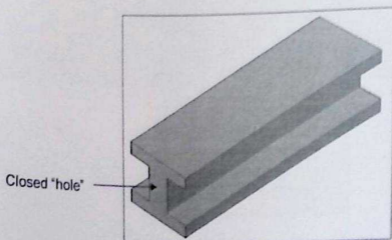
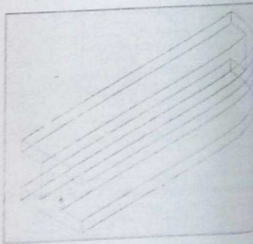

## AutoCAD 3D Tutorials

### Converting Meshes

Converts objects to surfaces. Objects that can be converted to surfaces include the following: 2D solids, 3D solids, Regions, open, zero-width polylines with thickness, lines with thickness, arcs with thickness, mesh objects, planar 3D faces

1. Type `CONVTOSURFACE` at the command prompt.  
Command: `CONVTOSURFACE`  
Mesh conversion set to: Smooth and optimized.  
Select objects: pick object  
Select objects: press enter

PLine with thickness

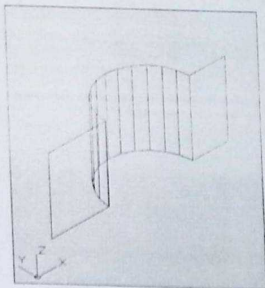

New converted mesh

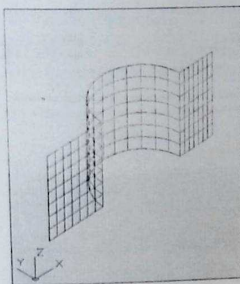

#### Smooth options

- Smooth, optimized**  
Creates a smooth model that merges faces.
- Smooth, not optimized**  
Creates a smooth model with the same number of faces as the original mesh object.
- Faceted, optimized**  
Creates an angular model that merges planar faces.
- Faceted, not optimized**  
Creates an angular model with the same number of faces as the original mesh object.

**AutoCAD 3D – Chapter 11  
Complex Surfaces**

## AutoCAD 3D Tutorials

### 11.1 Revolved Surfaces

Regenerates a three-dimensional model with hidden lines

1. Type **REVSURF** at the command prompt.  
Command: **REVSURF**  
Current wire frame density:  
**SURFTAB1=6 SURFTAB2=6**  
Select object to revolve: pick **path curve**  
Select object that defines the axis of revolution:  
pick line  
Specify start angle <0>: **enter**  
Specify included angle (+=ccw, -=cw) <360>: **enter**

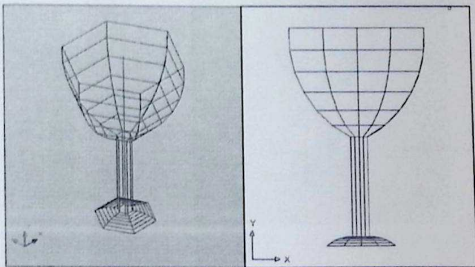
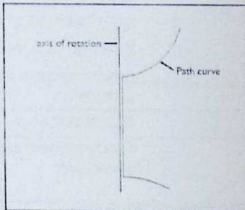

## AutoCAD 3D Tutorials

### 11.2 Surftab Variables

Sets the number of tabulations for both directions to be generated for RULESURF and TABSURF. Also sets the mesh density in ROTATE3D the M direction for REVSURF and EDGESURF commands.

1. Type Surftab1 at the command prompt.  
Command: SURFTAB1  
Enter new value for SURFTAB1 <6>: 30
2. Type Surftab2 at the command prompt.  
Command: SURFTAB2  
Enter new value for SURFTAB2 <6>: 30
3. Type Revsurf at the command prompt.  
Command: REVSURF  
Current wire frame density:  
SURFTAB1=30 SURFTAB2=30  
Select object to revolve: pick path curve  
Select object that defines the axis of revolution:  
pick line  
Specify start angle <0>: enter  
Specify included angle (+=ccw, -=cw) <360>  
press enter

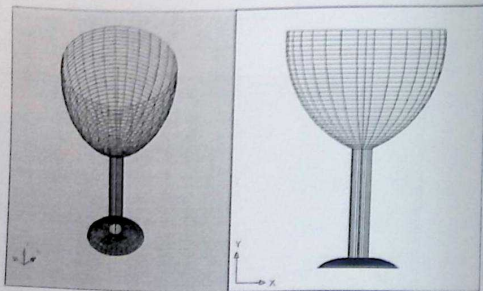

## AutoCAD 3D Tutorials

---

### 11.3 Tabulated Surfaces

1. Type `TABSURF` at the command prompt.  
Command: `TABSURF`  
Select object for path curve: Select object for direction vector:

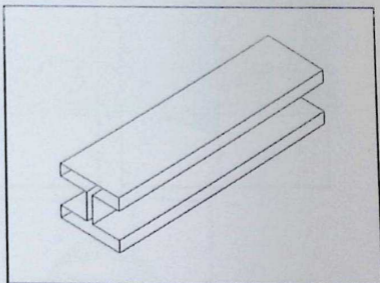
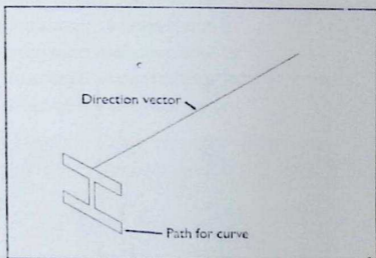

## AutoCAD 3D Tutorials

### 11.4 Ruled Surfaces

1. Type `RULESURF` at the command prompt.  
Command: `rulesurf`  
Current wire frame density: `SURFTAB1=6`  
Select first defining curve: `P1`  
Select second defining curve: `P2`

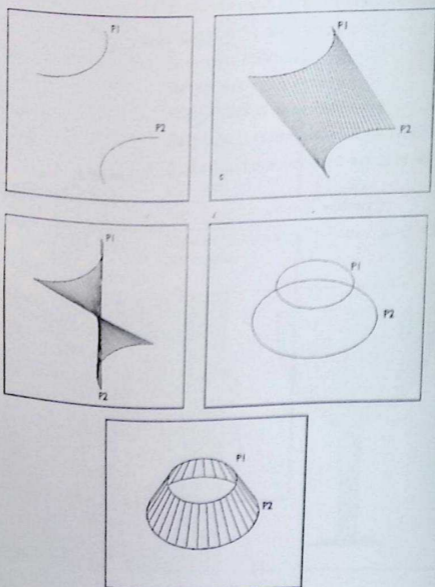

## AutoCAD 3D Tutorials

---

### 11.5 Edge Surfaces

Regenerates a three-dimensional model with hidden lines

1. Type EDGESURF at the command prompt  
Command: EDGESURF  
Current wire frame density:  
SURFTAB1=20 SURFTAB2=10  
Select object 1 for surface edge: P1  
Select object 2 for surface edge: P2  
Select object 3 for surface edge: P3  
Select object 4 for surface edge: P4

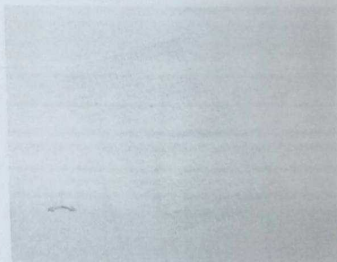

## AutoCAD 3D Tutorials

### 11.6 Planesurf

Creates a planar surface by selecting a closed object or by creating a rectangular plane.

1. Type `PLANESURF` at the command prompt.  
Command: `PLANESURF`  
Specify first corner or [Object] <Object>: press enter  
Select objects: pick object  
Select objects: press enter

Planar surface

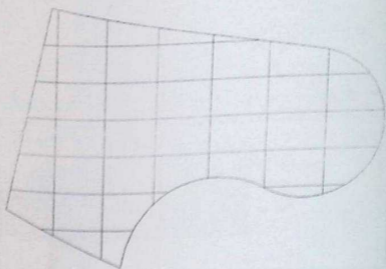

## AutoCAD 3D Tutorials

### 11.7 Extrude Surfaces

Creates a 3D solid or surface by extending the dimensions of an object.

1. Type      EXTRUDE at the command prompt.  
Command: EXTRUDE  
Current wire frame density: ISOLINES=4, Closed  
profiles creation mode = Surface  
Select objects to extrude or [MOde]: pick object  
creation mode  
[SOlid/SURface] <Solid>: \_su  
Select objects to extrude or [MOde] enter  
Specify height of extrusion or [Direction/Path/Taper  
angle/Expression]  
<1.4581>: 10

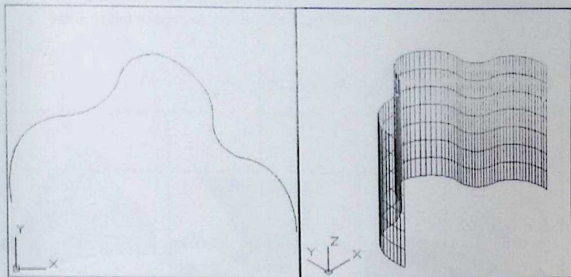

## AutoCAD 3D Tutorials

### 11.8 Loft Command

Creates a 3D solid or surface in the space between several cross sections.

1. Type **LOFT** at the command prompt.  
Command: **LOFT**  
Current wire frame density: ISOLINES=4, Closed profiles creation mode = Surface  
Select cross sections in lofting order or [Point/Join multiple edges/Mode]: **select object**  
Select cross sections in lofting order or [Point/Join multiple edges/Mode]: **select object**  
Select cross sections in lofting order or [Point/Join multiple edges/Mode]: **select object**  
Select cross sections in lofting order or [Point/Join multiple edges/Mode]: **3 cross sections selected**  
Enter an option [Guides/Path/Cross sections only/Settings] <Cross sections only>: **press enter**

Objects before



Surfaces using loft

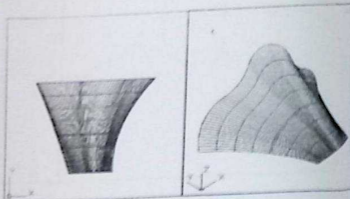

## AutoCAD 3D Tutorials

### 11.9 Sweep Command

Creates a 3D surface by sweeping a 2D or 3D curve along a path.

1. Type **SWEEP** at the command prompt.  
Command: **SWEEP**  
Current wire frame density: ISOLINES=4, Closed profiles creation mode = Surface  
Select objects to sweep or [MOde]: select object  
Select objects to sweep or [MOde]: select path (line)  
Select sweep path or [Alignment/Base point/Scale/Twist]:

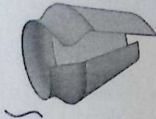
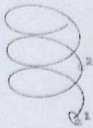
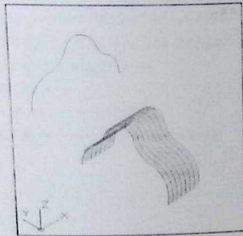
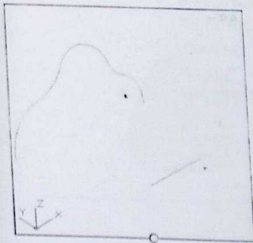

## AutoCAD 3D Tutorials

### 11.10 Surface Network

One way to create surfaces is with a network of curves. The SURFNETWORK command creates a surface similar to a lofted surface from a network of curves in the U and V directions.

A network surface also can be created from curves that are not all connected. The resulting surface can be either a procedural surface or a NURBS surface.

1. Type SURFNETWORK at the command prompt.  
Command: SURFNETWORK

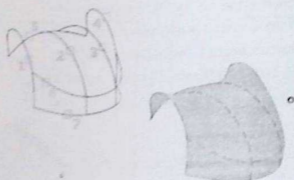

## AutoCAD 3D Tutorials

### 11.11 Revolve Surface

One way to create surfaces is with a network of curves. The SURFNETWORK command creates a surface similar to a lofted surface from a network of curves in the U and V directions.

A network surface also can be created from curves that are not all connected. The resulting surface can be either a procedural surface or a NURBS surface.

1. Type **REVOLVE** at the command prompt.  
Command: **REVOLVE**  
Current wire frame density: ISOLINES=4, Closed profiles creation mode = Surface  
Select objects to revolve or [MOde]: select object  
Select objects to revolve or [MOde]: press enter  
Specify axis start point or define axis by [Object/XY/Z]:  
<Object>: select endpoints of axis  
Specify axis endpoint:  
Specify angle of revolution or [STart angle/Reverse/EXpression] <360>: press enter

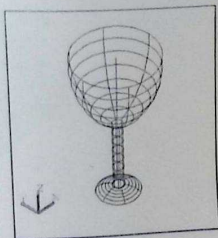
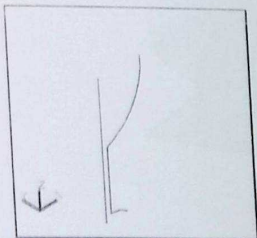

## AutoCAD 3D Tutorials

---

### 11.12 Surface Blend

Creates a blend surface between two existing surfaces.

1. Type SURFBLEND at the command prompt.  
Command: SURFBLEND

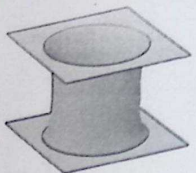
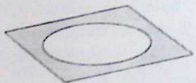
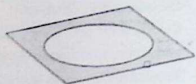

## AutoCAD 3D Tutorials

---

### 11.13 Surface Patch

Creates a new surface or cap to close an open edge of an existing surface.

1. Type SURFPATCH at the command prompt  
Command: SURFPATCH

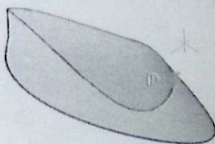
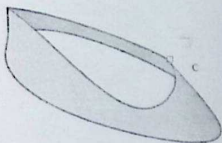

## AutoCAD 3D Tutorials

---

### 11.14 Offsetting Surfaces

Creates a parallel surface at a specified distance from the original surface.

1. Type `SURFOFFSET` at the command prompt.  
Command: `SURFOFFSET`



## AutoCAD 3D Tutorials

---

### 11.15 Editing Surfaces

#### Surface Fillet

1. Type `SURFFILLET` at the command prompt.  
Command: `SURFFILLET`

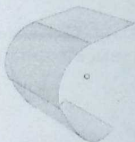

#### Surface Trim

1. Type `SURFTRIM` at the command prompt.  
Command: `SURFTRIM`

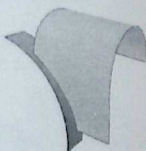
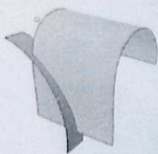

## AutoCAD 3D Tutorials

---

### Surface UnTrim

1. Type SURFUNTRIM at the command prompt.  
Command: SURFUNTRIM

### Surface Extend

1. Type SURFEXTEND at the command prompt.  
Command: SURFEXTEND

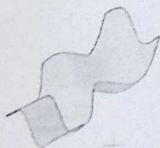

### Surface Suplt

1. Type SURFSCULPT at the command prompt.  
Command: SURFSCULPT

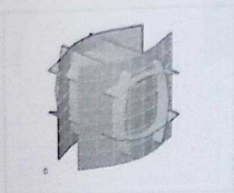

## AutoCAD 3D Tutorials

---

### Surface CV Edit Bar

Adds and edits control vertices on a NURBS surface or spline

1. Type SURFSCULPT at the command prompt  
Command: SURFSCULPT



### Convert to NURBS

1. Type CONVTONURBS at the command prompt  
Command: CONVTONURBS

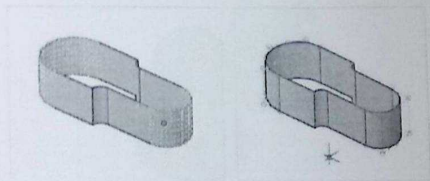

## AutoCAD 3D Tutorials

---

### 11.16 NURB Vertex Controls

#### Surface CV - Show

Shows NURB vertices

1. Type CVSHOW at the command prompt.  
Command: CVSHOW



#### Surface CV - Hide

Hides NURB vertices

1. Type CVHIDE at the command prompt.  
Command: CVHIDE



## AutoCAD 3D Tutorials

---

### Surface CV Rebuild

Rebuilds control vertices of NURBS surfaces or spline

1. Type `CVREBUILD` at the command prompt  
Command: `CVREBUILD`

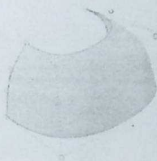

### Surface CV Add

Adds control vertices of NURBS surfaces or spline

1. Type `CVADD` at the command prompt  
Command: `CVADD`



## AutoCAD 3D Tutorials

---

### Surface Remove

Removes control vertices of NURBS surfaces or spline

1. Type `CVREMOVE` at the command prompt.  
Command: `CVREMOVE`

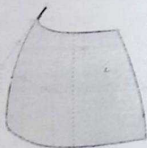

## AutoCAD 3D Tutorials

---

### 11.17 Surface Analysis

#### Analysis Zebra

Projects parallel lines onto a model to help you analyze surface continuity. The way the stripes line up where two surfaces meet helps analyze the tangency and curvature of the intersection.

1. Type `ANALYSISZEBRA` at the command prompt.  
Command: `ANALYSISZEBRA`

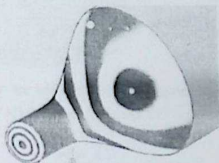

#### Analysis Curvature

Displays a color gradient onto a surface so you can evaluate the high and low areas of curvature.

1. Type `ANALYSISCURVATURE` at the command prompt.  
Command: `ANALYSISCURVATURE`



## AutoCAD 3D Tutorials

---

### Analysis Draft

Displays a color gradient onto a surface so you can evaluate if a model has adequate draft between a part and its mold

1. Type `ANALYSISDRAFT` at the command prompt.  
Command: `ANALYSISDRAFT`

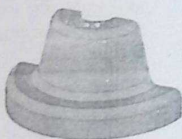

### 11.18 Work with Associative Surfaces and Constraints

#### SURFACEASSOCIATIVITY

Like hatch and dimensions, surfaces can also be associative. When a surface is moved or modified, any associated surface is adjusted automatically.

In this illustration, the boat is made up of four surfaces. When one of the sides is stretched and reshaped, all associated surfaces adjust accordingly. Use the SURFACEASSOCIATIVITY system variable to turn associativity on and off.

Associativity also allows you to apply mathematical expressions and parametric constraints to surfaces.

Mathematical expressions can be applied to surface properties such as radius and height. For example, you can specify that the height of a surface is always one half of the length of a solid box.

Parametric constraints restrict the relative position of one object to another. In this example, the arc that was extruded to create the surface is locked in a fixed position. When you edit the associated surface, the arc surface stays in place.

**AutoCAD 3D – Chapter 12**  
**Creating Solids**

## AutoCAD 3D Tutorials

---

### 12.1 Solid Primitives

Solid primitives can easily be drawn from from the 3D Modeling panel, Solid Panel .

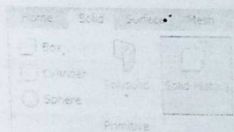

## AutoCAD 3D Tutorials

### 12.2 Polysolid Command

With the POLYSOLID command, you can convert an existing line, 2D polyline, arc, or circle to a solid with a rectangular profile. A polysolid can have curved segments, but the profile is always rectangular by default.

1. Open a drawing with a closed 2D polyline and display in a 3D view.
2. Type POLYSOLID at the command prompt.  
Command: polysolid  
Specify start point or [Object/Height/Width/Justify]  
<Object>: h  
Specify height <0'-4">: 10  
Specify start point or [Object/Height/Width/Justify]  
<Object>: o  
Select object: Pick polygon

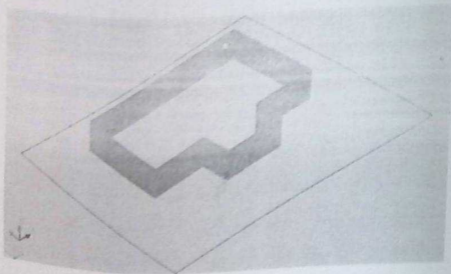

## AutoCAD 3D Tutorials

---

### 12.3 Extrude

Creates unique solid primitives by extruding existing two-dimensional objects. You can extrude multiple objects with EXTRUDE.

1. Type `EXTRUDE` at the command prompt.  
Command: `extrude`  
Current wire frame density: `ISOLINES=4`  
Select objects: pick objects  
Select objects: `enter`  
Specify height of extrusion or [Direction/Path/Taper angle]: `2`

*Lines with a Thickness of 2"*

*Lines Extruded 2"*

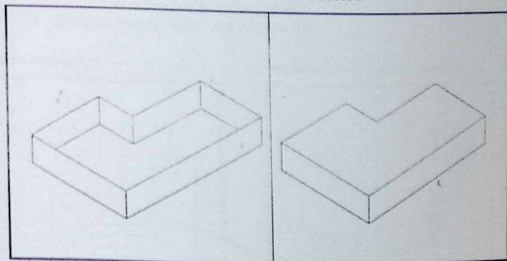

## AutoCAD 3D Tutorials

### 12.4 Extrude with Taper

1. Choose Draw, Modeling, Extrude.  
or
2. Type EXTRUDE at the command prompt.  
Command: extrude  
Current wire frame density: ISOLINES=4  
Select objects to extrude: pick object to extrude  
Select objects to extrude: enter  
Specify height of extrusion or [Direction/Path/Taper angle]: T  
Specify angle of taper for extrusion <0>: 15  
Specify height of extrusion or [Direction/Path/Taper angle]: 4

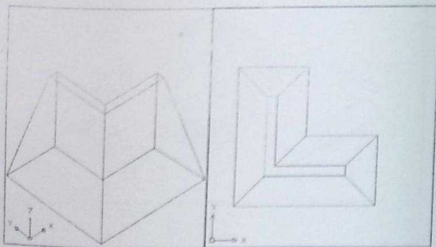

## AutoCAD 3D Tutorials

---

### 12.5 Extrude with Path

1. Type **EXTRUDE** at the command prompt.  
Command: **extrude**  
Current wire frame density: ISOLINES=4  
Select objects to extrude: 1 found  
Select objects to extrude: pick circle (P1)  
Specify height of extrusion or [Direction/Path/Taper angle] <4.0000>: p  
Select extrusion path or [Taper angle]: pick P2

*Circle Extruded Along a Path*

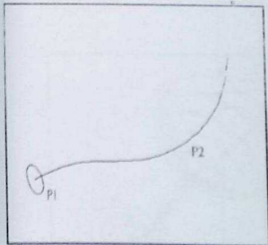

*Hidden Line Removal of Extruded Circle*

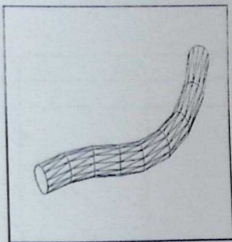

## AutoCAD 3D Tutorials

### 12.6 Revolve Command

1. Open a drawing with 3D objects and display in a 3D view.
2. Type REVOLVE at the command prompt.

Command: **revolve**

Current wire frame density: ISOLINES=4

Select objects: **pick profile**

Select objects: **enter**

Specify start point for axis of revolution or define axis

by [Object/X (axis)/Y (axis)]: **o**

Select an object: **pick axis**

Specify angle of revolution <360>: **enter**

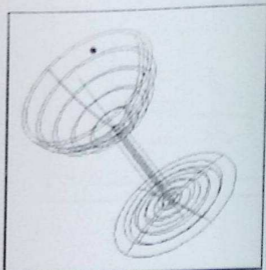
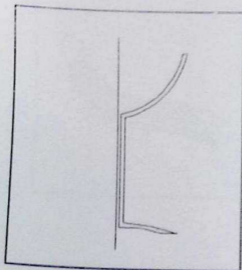

## AutoCAD 3D Tutorials

---

### 12.7 Sweep Command

1. Open a drawing with 2D objects to sweep and display in a 3D view.

2. Type SWEEP at the command prompt.

Command: sweep

Current wire frame density: ISOLINES=4

Select objects to sweep: pick arc

Select objects to sweep:

Select sweep path or [Alignment/Base point/Scale/Twist]: pick path

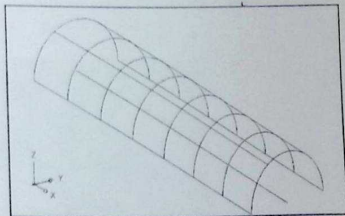
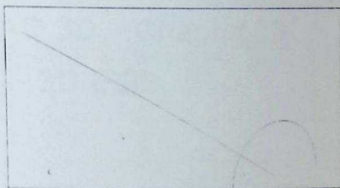

## AutoCAD 3D Tutorials

---

### 12.8 Loft Command

1. Open a drawing with 2D objects to sweep and display in a 3D view.
2. Type LOFT at the command prompt.

Command: loft

Select cross-sections in lofting order: pick circles  
Specify opposite corner: 5 found

Select cross-sections in lofting order:

Enter an option [Guides/Path/Cross-sections only]  
<Cross-sections only> enter

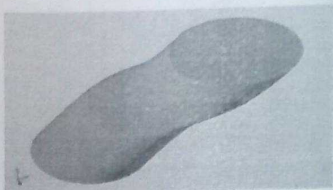
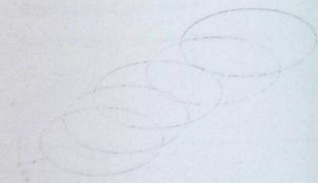

**AutoCAD 3D – Chapter 13**  
**3D Edits**

## AutoCAD 3D Tutorials

---

### 13.1 Convert to Solid

Converts polylines and circles with thickness to 3D solids. With the CONVTSOLID command, you can convert the following objects into extruded 3D solids:

- Uniform-width wide polylines with thickness
- Closed, zero-width polylines with thickness
- Circles with thickness

You cannot use CONVTSOLID with polylines that contain vertices with 0 width or that contain segments of variable width.

1. **Open** a drawing with 2D polylines or circles with thicknesses and display in a 3D view.
2. **Choose** **Modify, 3D Operation, Convert to Solid.**  
or
3. **Type** **CONVTSOLID** at the command prompt.  
Command: **convtsolid**  
Select objects: pick circle or polyline 1 found  
Select objects: press enter

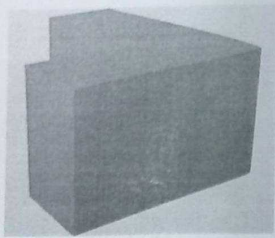
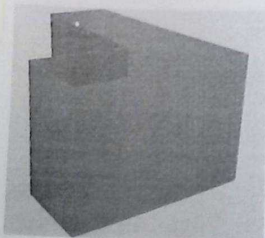

## AutoCAD 3D Tutorials

---

### 13.2 Convert to Surface

Converts polylines and circles with thickness to surfaces.

1. Open a drawing with 2D polylines or circles with thicknesses and display in a 3D view.
2. Choose Modify, 3D Operation, Convert to Surface or
3. Type `CONVTSURFACE` at the command prompt.

Command: `convtsurface`

Select objects: 1 found

Select objects:

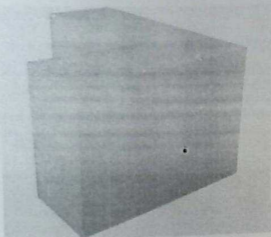
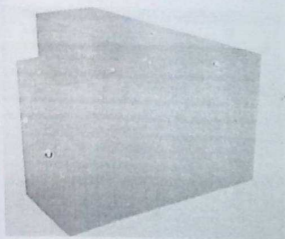

## AutoCAD 3D Tutorials

### 13.3 3D Move

Displays the move grip tool in a 3D view and moves objects a specified distance.

1. Open a drawing with 3D objects and display in a 3D view.
2. Choose Modify, 3D Operations, 3DMove  
or
3. Type 3DMOVE at the command prompt.

Command: 3Dmove

Select objects: pick object to move

1 found

Select objects: enter

Specify base point or [Displacement]

<Displacement>: D

Specify displacement <0.0000, 0.0000, 0.0000>: 0,0,2

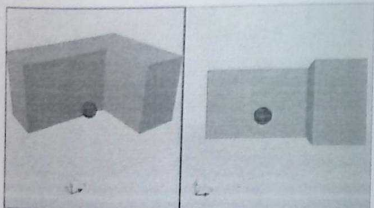
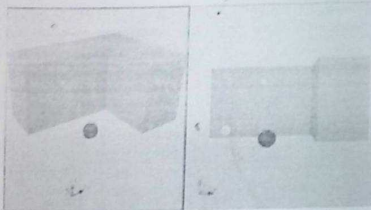

## AutoCAD 3D Tutorials

### 13.4 3D Rotate

1. Open a drawing with 3D objects and display in a 3D view.
2. Choose Modify, 3D Operations, 3DRotate.  
or

3. Type 3DROTATE at the command prompt

Command: 3DROTATE

Current positive angle in UCS:

ANGDIR=counterclockwise ANGBASE=0

Select objects: pick object and press enter

Specify base point: pick point

Pick a rotation axis: select X axis

Specify angle start point: -90

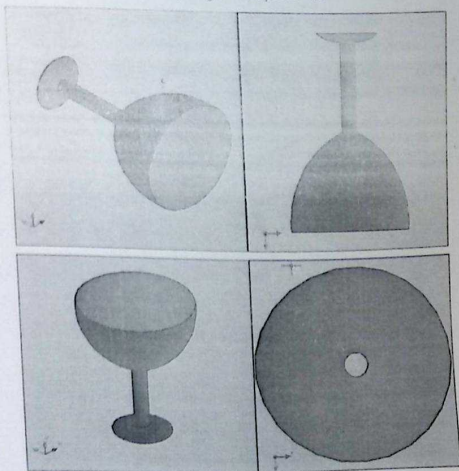

## AutoCAD 3D Tutorials

---

### 13.5 3DAlign

1. Open a drawing with 3D objects and display in a 3D view.
2. Choose `Modify, 3D Operations, 3DAlign.`  
or
3. Type `3DALIGN` at the command prompt.  
Command: `3DALIGN`  
Select objects: pick and press `enter`  
Specify source plane and orientation ...  
Specify base point or `[Copy]`:  
Specify second point or `[Continue] <C>`:  
Specify third point or `[Continue] <C>`:  
Specify destination plane and orientation ...  
Specify first destination point:  
Specify second destination point or `[eXit] <X>`:  
Specify third destination point or `[eXit] <X>`:

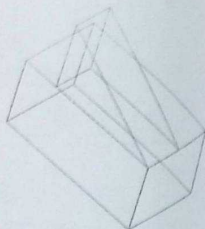
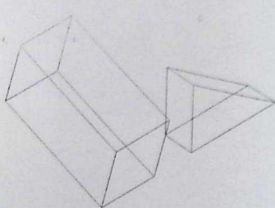

## AutoCAD 3D Tutorials

### 13.6 3D Mirror

1. Open a drawing with 3D objects and display in a 3D view.
2. Choose Modify, 3D Operations, 3DMirror.  
or
3. Type MIRROR3D at the command prompt.  
Command: mirror3D  
Select objects: pick the circle  
Select objects: enter  
Specify first point of mirror plane (3 points) or  
[Object/Last/Zaxis/View/XY/YZ/ZX/3points] <3points>  
P1  
Specify second point on mirror plane: P2  
Specify third point on mirror plane: P3  
Delete source objects? [Yes/No] <N>: enter  
*Circle Mirrored around 3 Points*

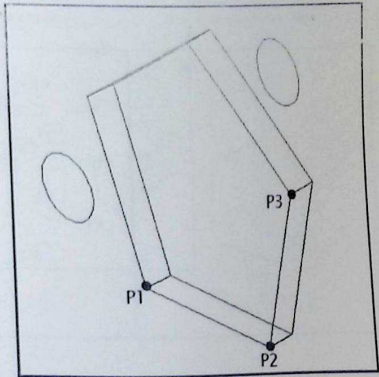

## AutoCAD 3D Tutorials

### 13.7 3D Rectangular Array

1. Open a drawing with 3D objects and display in a 3D view.
2. Choose Modify, 3D Operations, 3DArray.  
or
3. Type 3DARRAY at the command prompt.  
Command: 3darray  
Select objects: pick object and press enter  
Enter the type of array [Rectangular/Polar] <R>: R  
Enter the number of rows (---) <1>: 3  
Enter the number of columns (|||) <1>: 4  
Enter the number of levels (...) <1>: 2  
Specify the distance between rows (---): 5  
Specify the distance between columns (|||): 4  
Specify the distance between levels (...): 8

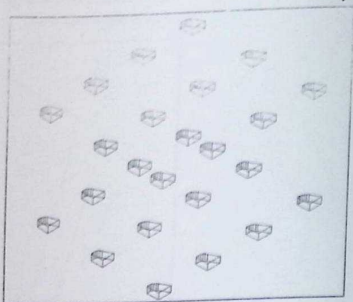

## AutoCAD 3D Tutorials

### 13.8 3D Polar Array

1. Open a drawing with 3D objects and display in a 3D view.
2. Choose Modify, 3D Operations, 3DArray.  
or
3. Type 3DARRAY at the command prompt.  
Command: 3darray  
Select objects: pick cube  
Select objects: enter  
Enter the type of array [Rectangular/Polar] <R> P  
Enter the number of items in the array: 5  
Specify the angle to fill (+=ccw, -=cw) <360> enter  
Rotate arrayed objects? [Yes/No] <Y> enter  
Specify center point of array: mid of axis line  
Specify second point on axis of rotation: pick

Arrayed Objects Around a Line

Arrayed Objects in Plan View

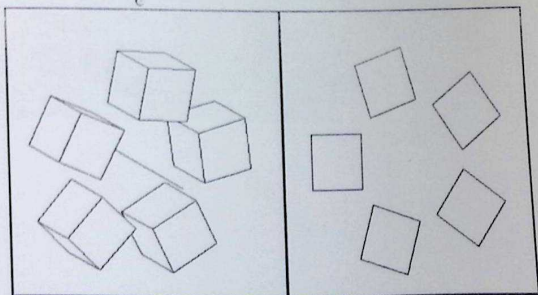

## AutoCAD 3D Tutorials

---

### 13.9 Extract Edges

1. Open a drawing with 3D objects and display in a 3D view.
2. Choose Modify, 3D Operations, Extract Edges.  
or
3. Type XEDGES at the command prompt.  
Command: `_xedges`  
Select objects: pick object  
Select objects: enter

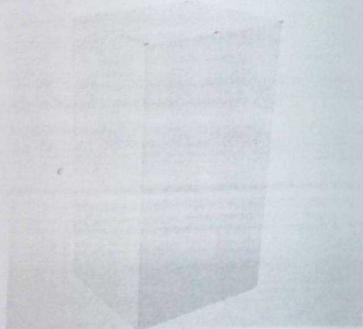

## AutoCAD 3D Tutorials

---

### 13.10 Facetres

Adjusts the smoothness of shaded and rendered objects and objects with hidden lines removed. Valid values are from 0.01 to 10.0.

1.° Open a drawing with 3D objects and display in a 3D view

2. Type FACETRES at the command prompt

Command: FACETRES

Enter new value for FACETRES <0.5000>: 10

Facetres=.1



○

Facetres=10



## AutoCAD 3D Tutorials

---

### 13.11 Isolines

1. Open a drawing with 3D objects and display in a 3D view.
2. Type ISOLINES at the command prompt.

Command: isolines

Enter new value for ISOLINES <4>: 20

Command: regen \*

REGEN Regenerating model.

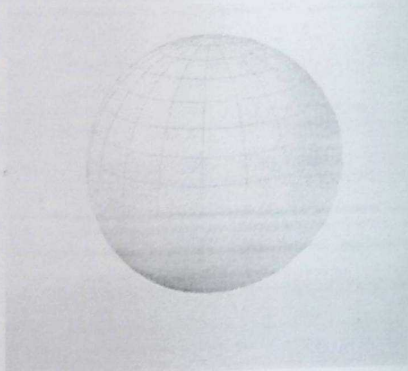

## AutoCAD 3D Tutorials

---

### 13.12 Edge Effects

1. Open a drawing with 3D objects and display in a 3D view.
2. Choose one of the edge effects from the View, Visual Styles ribbon panel.

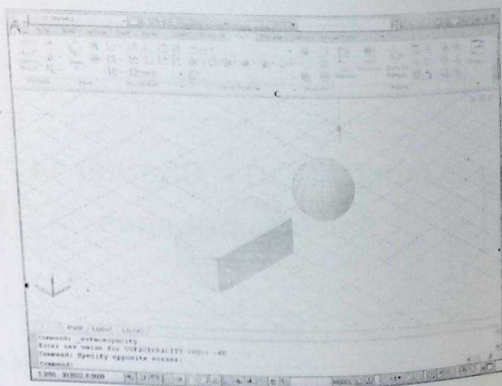

AutoCAD 3D – Chapter 14  
Solid Composites

## AutoCAD 3D Tutorials

### 14.1 Union

1. Open a drawing with 3D objects and display in a 3D view.
2. Choose Modify, Solids Editing, Union.  
or
3. Type UNION at the command prompt.

Command: UNION

Select objects: pick objects to union

Select objects: ENTER

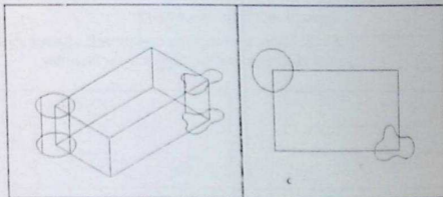

*Solid Objects Unioned Together*

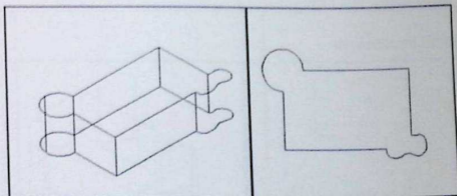

## AutoCAD 3D Tutorials

### 14.2 Subtract

1. Open a drawing with 3D objects and display in a 3D view.
2. Choose Modify, Solids Editing, Subtract.  
or
3. Type SUBTRACT at the command prompt.

Command: SUBTRACT

SUBTRACT Select solids and regions to subtract from...

Select objects: pick the main box

Select objects: (press enter)

Select solids and regions to subtract... Select objects: pick the other solids  
Select objects: enter

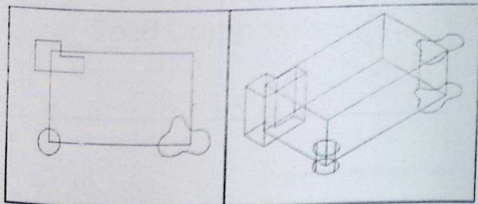

Objects Subtracted from Box

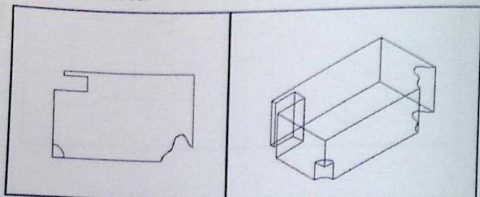

## AutoCAD 3D Tutorials

---

### 14.3 Intersect

1. Choose **Modify, Solids Editing, Intersect**  
or
2. Type **INTERSECT** at the command prompt.

Command: **INTERSECT**

Select objects: pick objects

Select objects: enter

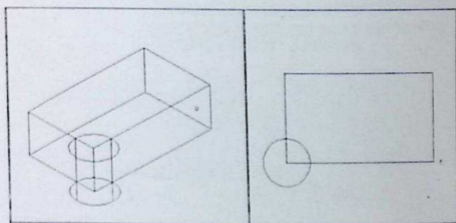

*Intersection of Cylinder and Box*

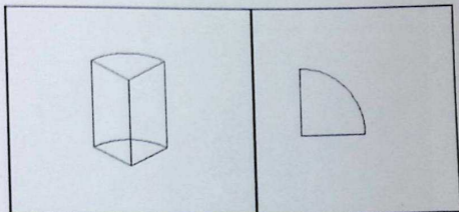

## AutoCAD 3D Tutorials

---

### 14.4 Thicken

Creates a 3D solid by thickening a surface.

1. Open a drawing with 3D surface and display in a 3D view.
2. Choose Modify, 3D Operation, Thicken.  
or
3. Type THICKEN at the command prompt.  
Command: THICKEN  
Select surfaces to thicken: 1 found  
Select surfaces to thicken:  
Specify thickness <0.0000>: 1

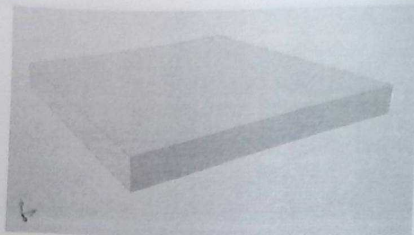

## AutoCAD 3D Tutorials

### 14.5 Interference Checking

Highlights 3D solids that overlap.

1. Open a drawing with 3D objects that overlap and display in a 3D view.
2. Choose `Modify, 3D Operations, Interference Checking`  
or
3. Type `INTERFERE` at the command prompt.  
Command: `INTERFERE`  
Select first set of objects or [Nested selection/Settings]: pick solids surrounding rectangle and and press enter.

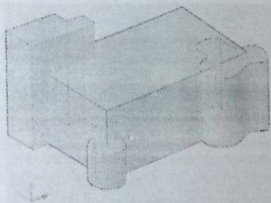

Select second set of objects or [Nested selection/check first set] <checkK>: pick rectangle and press enter

Solids that interfere will highlight in red.

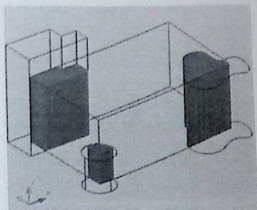

## AutoCAD 3D Tutorials

The following dialog box allows you to change the zoom and display of the drawing to better see the interfering objects.

You can also choose to retain the interference objects by turning the check box off for "Delete interference objects created on Close"

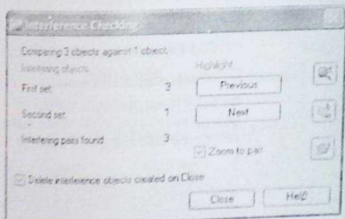

**AutoCAD 3D – Chapter 15**  
**Modifying Solid Faces**

## AutoCAD 3D Tutorials

### 15.1 Extrude Face

1. Choose **Modify, Solid Editing, Extrude face.**
2. Choose **NOTE: Must be a solid to extrude the face. a face to extrude. If you choose more than one face, hold the SHIFT key to deselect unwanted faces.**
3. Press **ENTER.**
4. Specify **height of extrusion or [Path]: 25**
5. Specify **angle of taper for extrusion <0>: 45**

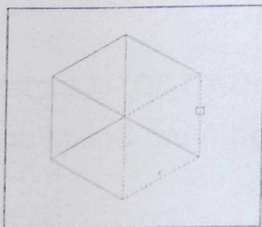

Select Face

Extruded Face

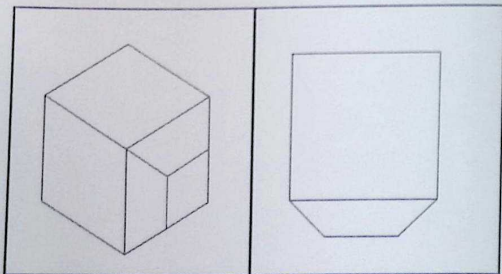

## AutoCAD 3D Tutorials

---

### 15.2 Taper Face

1. Choose **Modify, Solid Editing, Taper face.**
2. Choose a face(s) to taper. If you choose more than one face, hold the SHIFT key to deselect unwanted faces.
3. Press **ENTER.**
4. Specify the base point: **pick the back left corner**
5. Specify another point along the axis of tapering: **pick point**
6. Specify the taper angle: **45**  
Solid validation started. Solid validation completed.

*Before Taper*

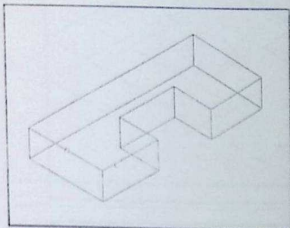

*After Taper*

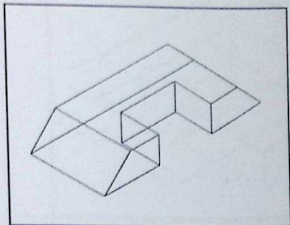

## AutoCAD 3D Tutorials

---

### 15.3 Delete Face

1. Choose **Modify, Solid Editing, Delete face.**
2. Choose a face to delete. If you choose more than one face, hold the SHIFT key to deselect unwanted faces.
3. Press **ENTER.**
4. Choose the face to delete.

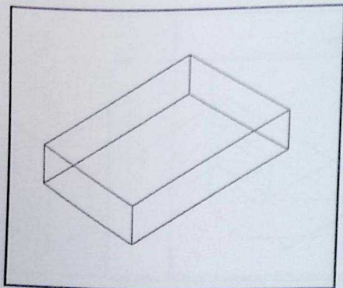
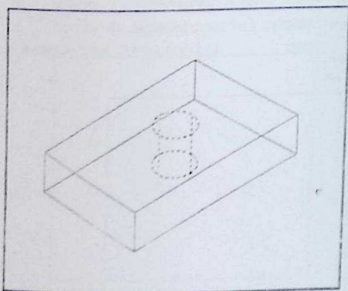

## AutoCAD 3D Tutorials

---

### 15.4 Copy Face

1. Choose **Modify, Solid Editing, Copy face.**
2. Choose a face to copy . If you choose more than one face, hold the SHIFT key to deselect unwanted faces.
3. Press **ENTER**
4. Pick the solid face to copy.
5. Pick a new location.

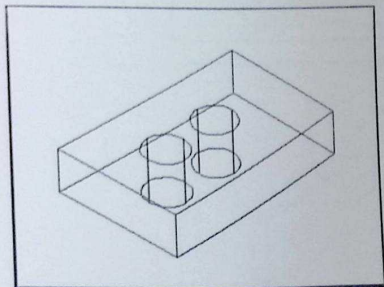
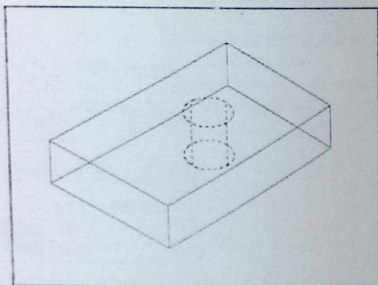

## AutoCAD 3D Tutorials

### 15.5 Color Face

1. Choose **Modify, Solid Editing, Color face.**
2. Choose a face to change the color of. If you choose more than one face, hold the SHIFT key to deselect unwanted faces.
3. Press **ENTER.**
4. Choose a color to change the face to.

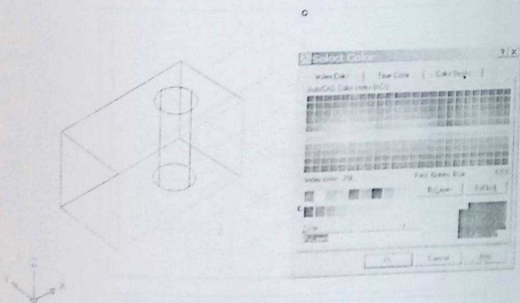

## AutoCAD 3D Tutorials

### 15.6 Imprint

Imprints an object on the selected solid. The object to be imprinted must intersect one or more faces on the selected solid in order for imprinting to be successful. Imprinting is limited to the following objects: arcs, circles, lines, 2D and 3D polylines, ellipses, splines, regions, bodies, and 3D solids

1. Extrude objects (i.e. walls) to create a solid object
2. Change the UCS and draw an object on a face of one of the walls.
3. Choose **Modify, Solid Editing, Imprint.**
4. Select a 3D solid: **pick solid**
5. Select an object to imprint: **pick circle**
6. Delete the source object <N>: **Y**

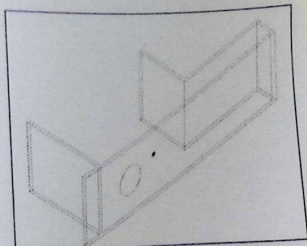
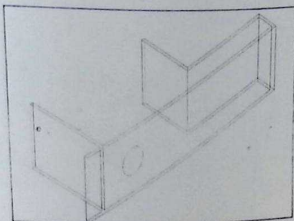

## AutoCAD 3D Tutorials

---

### 15.7 Extrude Imprint

1. Choose Modify, Solid Editing, Extrude Faces.
2. Select the circle that was imprinted in 15.6.
3. Deselect any unwanted faces.
4. Type -8 as the height of extrusion (or desired height).

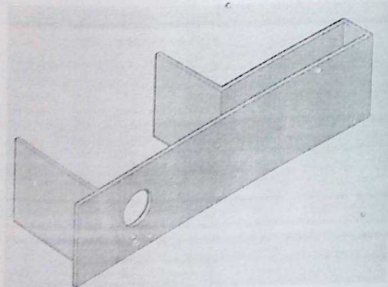

## AutoCAD 3D Tutorials

---

### 15.9 Shell

You can create a shell or a hollow thin wall with a specified thickness from your 3D solid object. AutoCAD creates new faces by offsetting existing ones inside or outside their original positions. AutoCAD treats continuously tangent faces as single faces when offsetting.

1. Choose **Modify, Solid Editing, Shell**
2. Select a 3D solid: pick solid
- Remove faces or [Undo/Add/ALL]: enter
- Enter the shell offset distance: .5

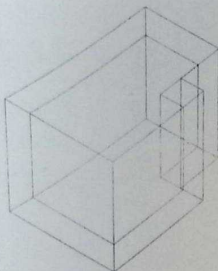
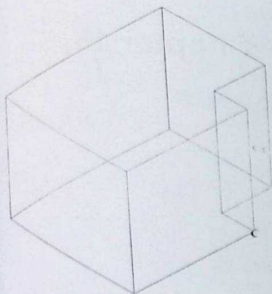

## AutoCAD 3D Tutorials

---

### 15.7 Extrude Imprint

1. Choose **Modify, Solid Editing, Extrude Faces.**
2. Select the circle that was imprinted in 15.6.
3. Deselect any unwanted faces.
4. Type **-8** as the height of extrusion (or desired height).

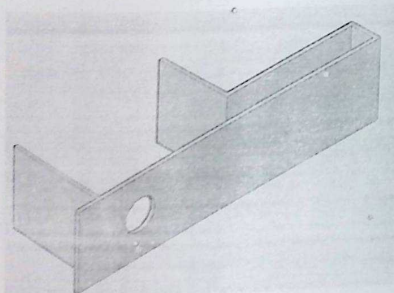

## AutoCAD 3D Tutorials

---

### 15.9 Shell

You can create a shell or a hollow thin wall with a specified thickness from your 3D solid object. AutoCAD creates new faces by offsetting existing ones inside or outside their original positions. AutoCAD treats continuously tangent faces as single faces when offsetting.

1. Choose **Modify, Solid Editing, Shell.**
2. Select a 3D solid: pick solid faces or [Undo/Add/ALL]. enter the shell offset distance: .5

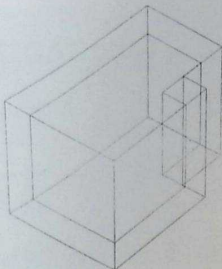
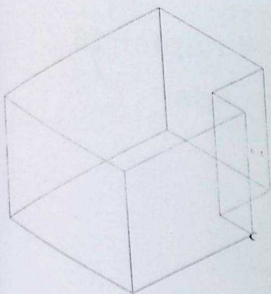

**AutoCAD 3D – Chapter 16**  
**Editing Solids**

## AutoCAD 3D Tutorials

---

### 16.1 Select and Manipulate Subobjects

You can select one subobject, or create a selection set of more than one subobject on any number of solids. Your selection set can also include more than one type of subobject.

1. Open a drawing with 3D solid object and display in a 3D view.
2. Hold the CTRL key and select the solid.
3. Toggle to other subobjects within the solid while holding the CTRL key.
4. Click and drag to modify the solid.

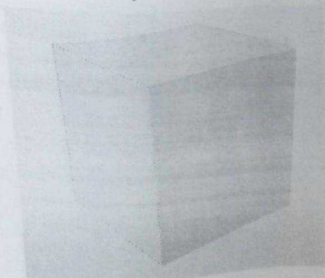

## AutoCAD 3D Tutorials

---

### 16.2 Use Grip Tools

Grip tools are icons that you use in a 3D view to easily constrain the movement or rotation of a selection set of objects to an axis or a plane.

There are two types of grip tools:

Move (3DMOVE command)

Rotate (3DROTATE command)

1. Open a drawing with 3D solid object and display in a 3D view.
2. Hold the CTRL key and select the solid
3. Toggle to other subobjects within the solid while holding the CTRL key.
4. Click and drag to modify the solid using the grip tool.

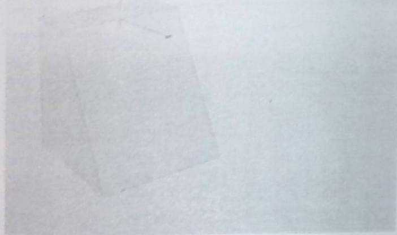

## AutoCAD 3D Tutorials

### 16.3 Press or Pull Bounded Areas

You can press or pull bounded areas by pressing and holding CTRL + ALT, or by clicking the Presspull button on the dashboard and then picking the bounded area. The area must be bounded by coplanar lines or edges.

1. Open a drawing with a 3D object and imprinted object and display in a 3D view.
2. Hold the CTRL and ALT keys and select the imprinted object or solid face to manipulate it.
3. Click and drag to a new location.

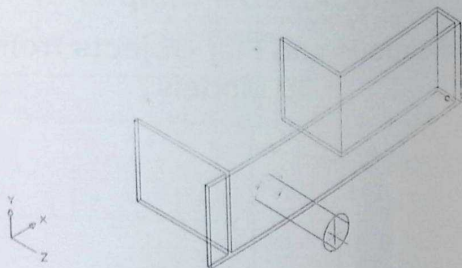

**AutoCAD 3D – Chapter 17  
Sections and Flat Objects from  
3D Models**

## AutoCAD 3D Tutorials

### 17.1 Sectionplane Command

The SECTIONPLANE command creates a section object that exposes the interior details of a model created with 3D objects.

Once you create a section object, you can move and manipulate it to fine-tune the sectional view you want.

1. Open a drawing with 3D solid objects and display in a plan and 3D view.

2. Choose Draw, Modeling, Sectionplane  
or

Type SECTIONPLANE at the command prompt:

Command: SECTIONPLANE

Select face or any point to locate section line or [Draw section/Orthographic]: O

Align section to: [Front/bAck/Top/Bottom/Left/Right]  
<Front>: FRONT (enter)

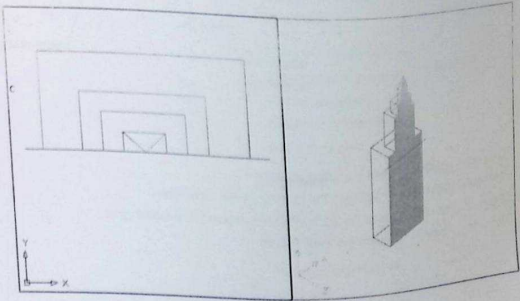



## AutoCAD 3D Tutorials

### 17.3 Section Shortcut Commands

1. Right-click on a section line to see the following section options.
2. Click the various section options.

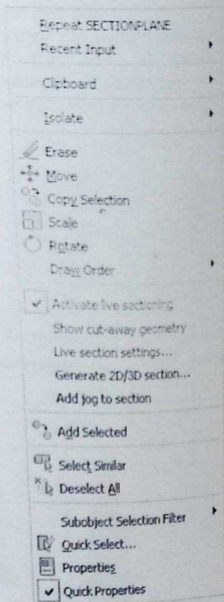

## AutoCAD 3D Tutorials

### 17.4 Generate 2D and 3D Sections

1. Right-click on a section line.
2. Click Generate 2D/3D section...
3. Click the down arrow from the following dialog box to see all of the section options.

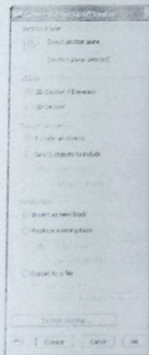

4. Choose 2D Section and Create.
5. Click an insertion point and scale for the 2D section block.

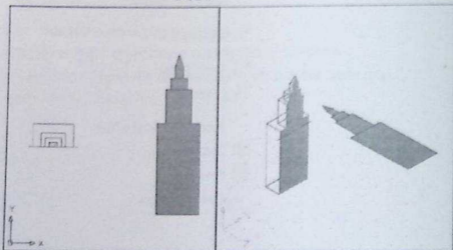

## AutoCAD 3D Tutorials

---

### 17.5 Section Command

Uses the intersection of a plane and solids to create a region

1. Open a drawing with 3D objects and display in a 3D view.
2. Type SECTION at the command prompt.

Command: SECTION

Select objects: pick solid and press enter

Specify first point on Section plane by

[Object/Zaxis/View/XY/YZ/ZX/3points] <3points> XY

Specify a point on the XY-plane <0,0,0> MID of

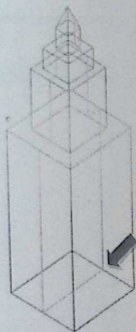
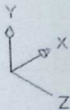

## AutoCAD 3D Tutorials

### 17.6 Slice Command

1. Open a drawing with 3D objects and display in a 3D view.
2. Choose Modify, 3D Operation, Slice.  
or
3. Type SLICE at the command prompt  
Command: slice  
Select objects to slice: 1 found  
Specify start point of slicing plane or [planar  
Object/Surface/Zaxis/View/XY/YZ/ZX/3points]  
<3points>: YZ  
Specify a point on the YZ-plane <0,0,0>: MID of  
Specify a point on desired side or [keep Both sides]  
<Both>:

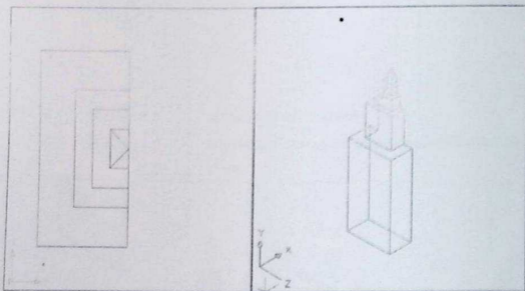

## AutoCAD 3D Tutorials

### 17.7 Flatshot

Creates a 2D or "flattened" representation of all 3D objects in the current view.

1. Click the Solid Editing dropdown from the Solid, Section ribbon panel.



or

2. Type **FLATSHOT** at the command prompt  
Command: **flatshot**

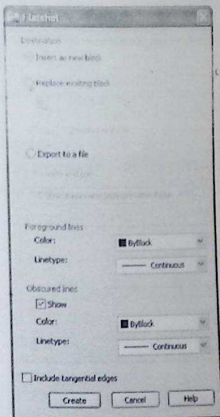

## AutoCAD 3D Tutorials

---

3. Click      Create and a location point for a block to insert.

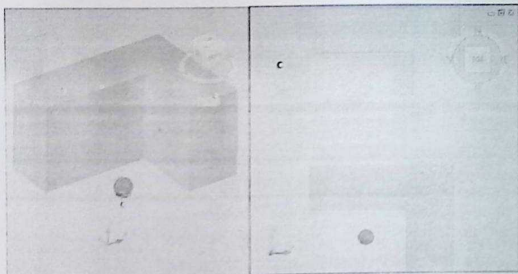

## AutoCAD 3D Tutorials

### 17.8 Solview

1. Choose File, New...
2. Choose "Use a Template" from the startup dialog
3. Double-click acad.dwt as the template file to start from.

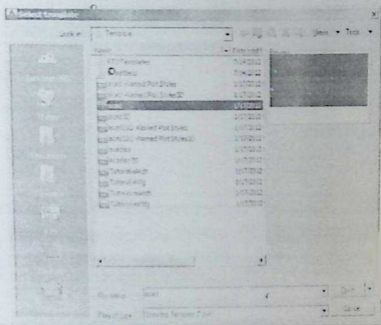

4. Create a new layout .
5. Move and resize the model view so it is in the upper left corner of the sheet as follows.

## AutoCAD 3D Tutorials

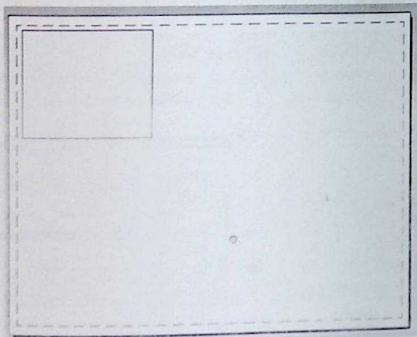

6. Type `MSPACE` at the command prompt
7. Type `INSERT` at the command prompt and choose the drawing called `3DBOTTLE.DWG` to insert. Explode the Block as you are inserting it.

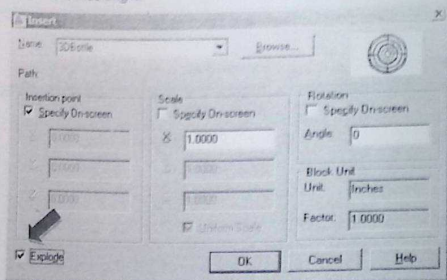

## AutoCAD 3D Tutorials

---

8. Insert the block anywhere in the Model Space view at a scale of 1 and rotation 0.
9. Type ZOOM EXTENTS then ZOOM 1XP.
10. Type PSPACE at the command prompt.
11. Change the layout paper size to ANSIC (22 x17).

Model Space View Scaled 1XP

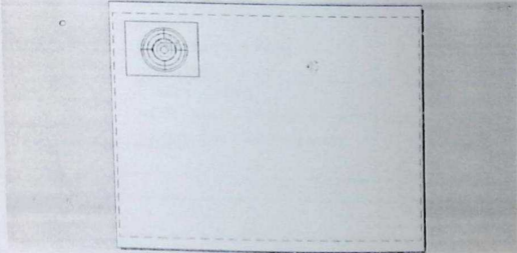

12. Type

SOLVIEW at the command prompt.

Command: SOLVIEW

Ucs/Ortho/Auxiliary/Section/<eXit>: O

Pick side of viewport to project: pick bottom "front" of the viewport.

View center: drag a point below the current viewport

Specify first corner of viewport: click upper left corner

Specify opposite corner of viewport: click lower right corner

Enter view name: FRONT

Enter an option [Ucs/Ortho/Auxiliary/Section]: enter

## AutoCAD 3D Tutorials

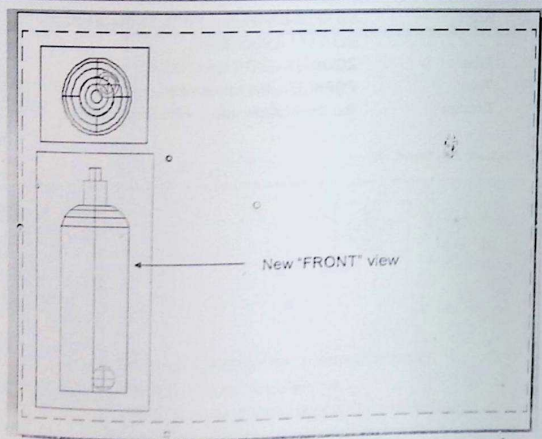

## AutoCAD 3D Tutorials

### 17.10 Soldraw

Generates profiles and sections in viewports created with SOLVIEW. SOLDRAW can only prepare viewports that have been created with SOLVIEW.

1. Type **SOLDRAW** at the command prompt  
Command: **SOLDRAW**  
Select viewports to draw: Pick the front viewport created above  
Select objects: 1 found  
Select objects: enter  
3 solids selected.  
NOTE: If your object was an inserted block, you need to first explode it so it becomes a solid

*Resultant Section and Solid*

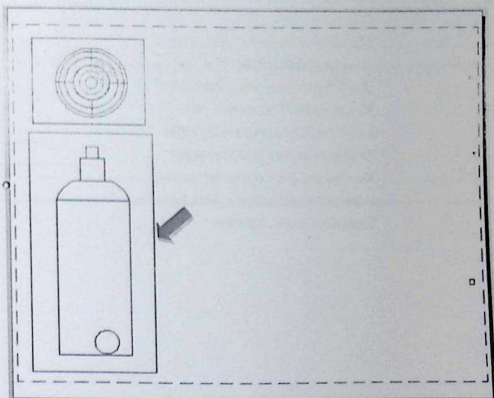

## AutoCAD 3D Tutorials

---

### 17.11 Create 3D View Using UCS

1. Type MSPACE and the plan view of the 3D Bottle.
2. Choose View, 3D Viewport, SW Isometric...
3. Type UCS at the command prompt.  
Command: UCS  
Origin/ZAxis/3point/Obje~~ct~~/View/X/Y/Z/  
Prev/Restore/Save/Del/?/World>: VIEW  
This sets the current UCS parallel to the screen. We now need to save this ucs.
4. Type UCS at the command prompt.  
Command: UCS  
Origin/ZAxis/3point/Obje~~ct~~/View/X/Y/Z/  
Prev/Restore/Save/Del/?/World>: SAVE  
?/Desired UCS name: 3DVIEW
5. Type PSPACE at the command prompt.  
Command PSPACE
6. Type SOLVIEW at the command prompt.  
Command: SOLVIEW,  
Ucs/Ortho/Auxiliary/Section/Exit>: U  
Named/World/?/Current>: N  
Name of UCS to restore: 3DVIEW  
Enter view scale<1.0000>: enter  
View center: pick upper left corner  
View center: pick lower right corner  
Enter view name: 3DVIEW

## AutoCAD 3D Tutorials

---

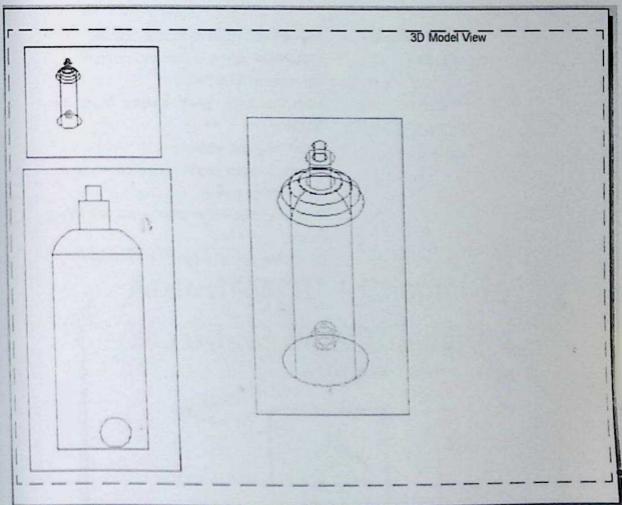

## AutoCAD 3D Tutorials

### 17.12 Solid Profile

1. Double-click
2. Type

MODEL to return to Model Space.  
SOLPROF at the command prompt.

Command: SOLPROF

Select objects: pick solids from the  
3DView

Select objects: enter

Display hidden profile lines on separate  
layer? <Y>: enter

Project profile lines onto a plane? <Y>:  
enter

Delete tangential edges? <Y>: enter  
3 solids selected.

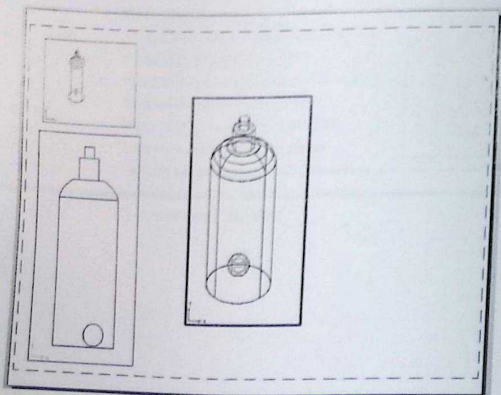

**AutoCAD 3D – Chapter 18**  
**Introduction to Rendering**

## AutoCAD 3D Tutorials

### 18.1 Render Command

Creates a photorealistic or realistically shaded image of a three-dimensional wireframe or solid model.

1. Open an AutoCAD drawing with 3D objects to render.
2. Choose View, Render, Render...  
or  
c
3. Type RENDER at the command prompt, c  
Command: RENDER

The following render window is the result of default rendering

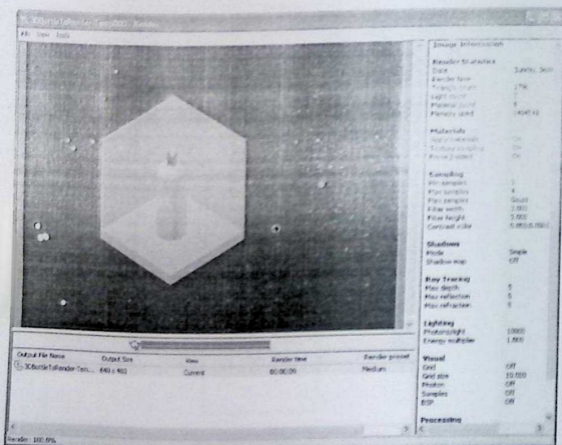

# AutoCAD 3D Tutorials

## 18.2 Render Destination

You are able to determine the output site that the renderer uses to display the rendered image. Two options are the render window and viewport.

1. Choose **View, Render, Advanced Render Settings...**  
OR
2. Type **RPREF** at the command prompt.  
Command: **RPREF**
3. Click the dropdown option for destination and choose **Viewport**.

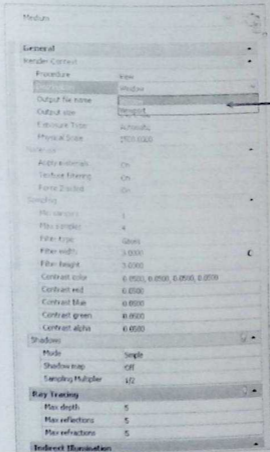

4. Close the render preferences and render your objects to the viewport.

## AutoCAD 3D Tutorials

---

### 18.3 Render Quality

1. Choose **View, Render, Advanced Render Settings...**  
or
2. Type **RPREF** at the command prompt.  
Command: **RPREF**
3. Click the dropdown option for the render quality and choose **Presentation**.

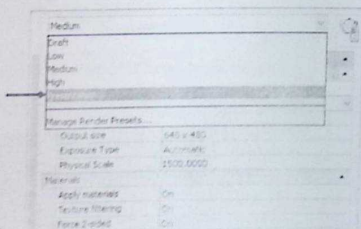

4. Close the render preferences and render your view.

Note: Depending on the objects, lights, materials, etc. in your model, rendering in presentation mode might take a long time.

## AutoCAD 3D Tutorials

### 18.4 Render Selection

Controls the parts of the model that gets processed during rendering. The render procedure has three settings: View, Crop, and Selected.

1. Choose View, Render, Advanced Render Settings...  
or
2. Type RPREF at the command prompt.  
Command: RPREF
3. Click the dropdown option for Procedure and choose Selected.

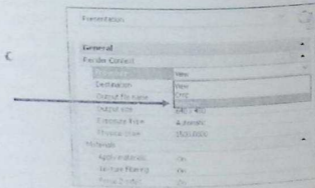

4. Close the render preferences and render selected objects.

*This result is a selected object in the drawing that is rendered.*



## AutoCAD 3D Tutorials

### 18.5 Render Cropped Window

1. Choose View, Render, Advanced Render Settings...  
or
2. Type RPREF at the command prompt.  
Command: RPREF
3. Click dropdown option for Procedure and choose Crop

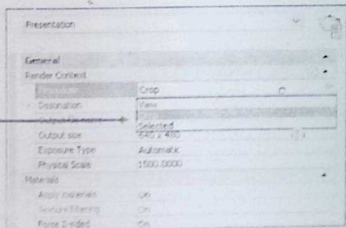

4. Close the render preferences and render a cropped window.

The result is a cropped portion of the drawing that is rendered.

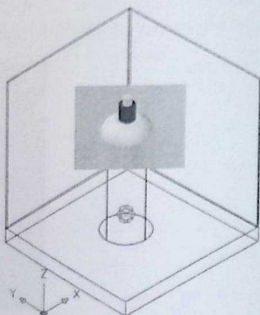

## AutoCAD 3D Tutorials

### 18.6 Render to File

1. Type RPREF at the command prompt.
2. Click the small disk beside the title for "Render Content".
3. Click the option for Output file name.

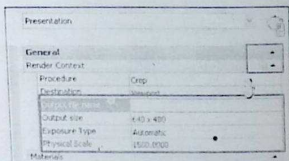

4. Choose a location, format, and file name for your rendered objects.
5. Adjust the image quality and click OK.
6. Close the render preferences and render your objects.

The result is a rendered image to a file that you can copy, print, or manipulate in any imaging software application.

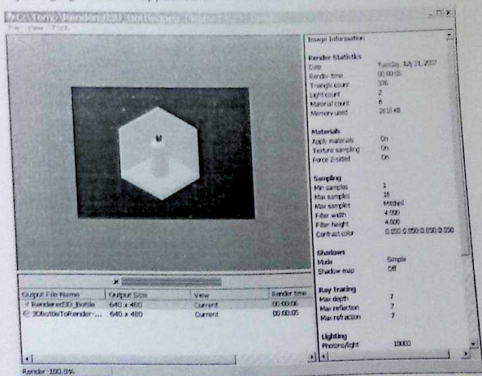

## AutoCAD 3D Tutorials

---

### 18.7 Turn Off Render to File

1. Open an AutoCAD drawing with 3D objects to render.
2. Choose View, Render, Advanced Render Settings...  
or
3. Type RPREF at the command prompt.  
Command: RPREF
4. Click the small disk beside the title for "Render Content".  
You will notice that the Output file name option will be grayed out.

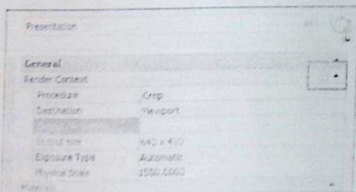

**AutoCAD 3D – Chapter 19**  
**Materials**

## AutoCAD 3D Tutorials

### 19.1 Adding Material to a Drawing

1. Open an AutoCAD drawing with 3D objects to add materials to.
2. Choose **View, Render, Materials Brower ...**  
or
3. Type **MATERIALS** or **MATBROWSEROPEN** at the command prompt.  
Command: **MATERIALS** or **MARBROWSEROPEN**
4. Click the categories button to see more switches.
5. Browse the various materials in the Autodesk Library.

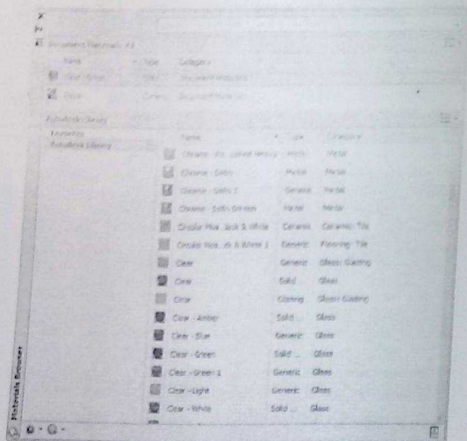

## AutoCAD 3D Tutorials

### 19.2 Apply Material to Objects

1. Click and drag the following materials into the document section of the materials browser.

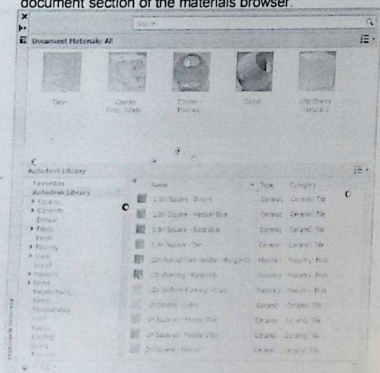

2. Select an object and select a material.

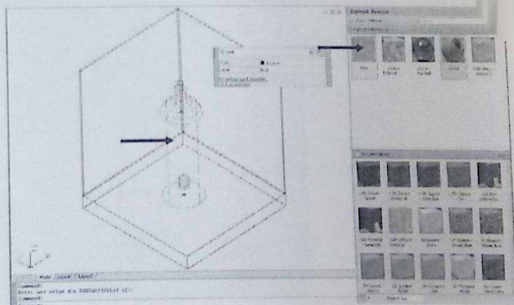

## AutoCAD 3D Tutorials

---

3. Type RENDER at the command prompt to see the new material applied in the drawing.

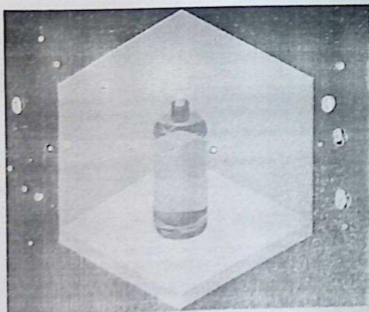

4. Apply additional materials to objects and render the drawing.

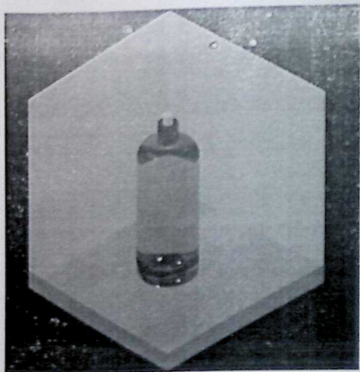

## AutoCAD 3D Tutorials

### 19.3 Show Objects Materials Applied To

1. Right-click a material in the Document Materials section.
2. Click Select Objects Applied To

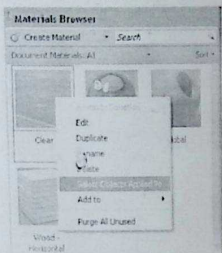

Object(s) with attached materials are selected in the drawing.

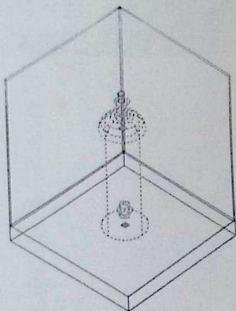

## AutoCAD 3D Tutorials

### 19.4 Edit Material

1. Right-click a material in the Document Materials section.
2. Click Edit.

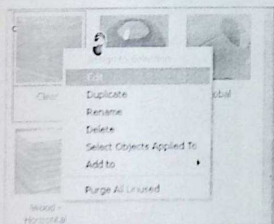

3. Change one or more properties of the material.

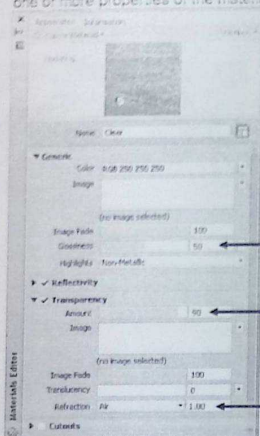

## AutoCAD 3D Tutorials

---

Render the viewport to see the material changes

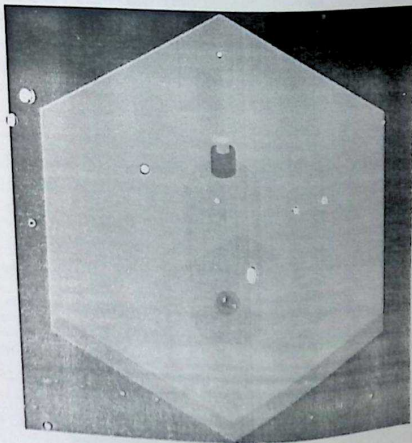

## AutoCAD 3D Tutorials

### 19.5 Adjust Material Scale

Materials such as hard wood might not map properly to objects at different scales. The follow section shows how to adjust the scale of materials.

1. Right-click a material in the Document Materials window.
2. Click Edit.

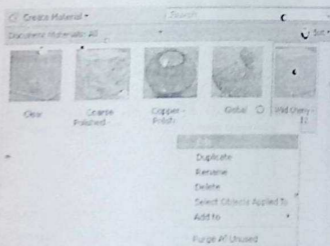

3. Click the image picture to edit it.

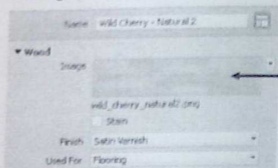

4. Click the **Transforms** dropdown.
5. Click the **Scale** dropdown and change the width and height.

## AutoCAD 3D Tutorials

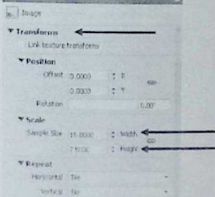
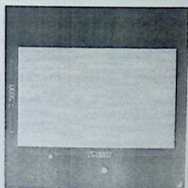

Render the viewport to see the newly scaled material.

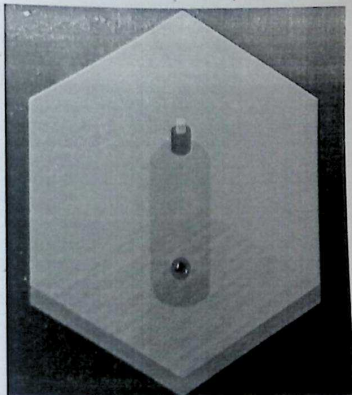

## AutoCAD 3D Tutorials

### 19.6 Applying Materials by Layer

You can attach a material to an entire layer using the Material Attach command.

1. Add the material Concrete Polished White to your Document Materials.



2. Type `MATERIALATTACH` at the command prompt  
Command: `MATERIALATTACH`
3. Click and drag the concrete material onto layer Wall.

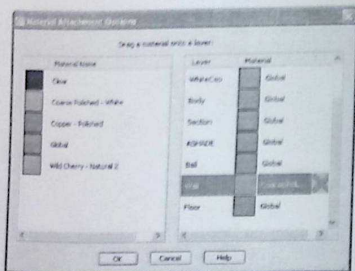

## AutoCAD 3D Tutorials

---

Render the drawing to see the new material attached to the wall layer.

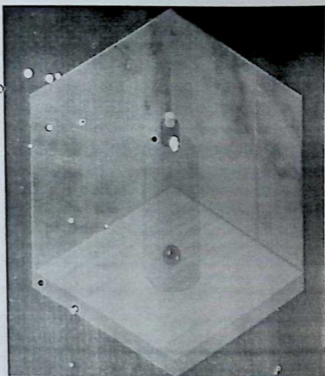

## AutoCAD 3D Tutorials

### 19.7 Create a New Material

1. Open a drawing without materials.
2. Choose **View, Render, Material Browser**  
or
3. Type **MATERIALS** at the command prompt  
Command: **MATERIALS**
4. Click the **Create Material** button and **Wall Paint**.

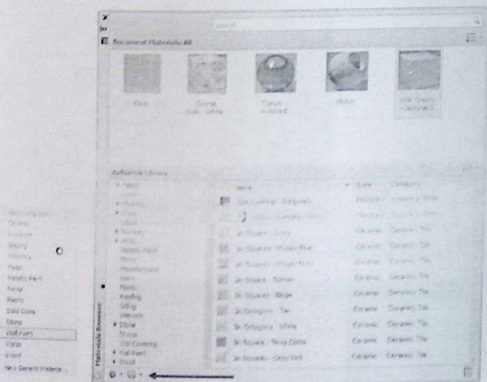

5. Type **Wall Paint – Eggshell Green** as the new material name.
6. Choose a blue green color.

## AutoCAD 3D Tutorials

---

7. Choose Eggshell as the finish.



8. Apply the material to a wall in the drawing

Render the drawing to see the newly created material.

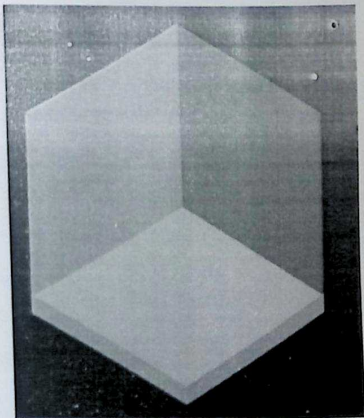

## AutoCAD 3D Tutorials

### 19.8 Create Photo as Material

1. Choose **View, Render, Materials...**
2. Type **MATERIALS** at the command prompt.  
Command: **MATERIALS**
3. Click the **Create Material** button and **New Generic Material**.
4. Name the material **Photo**.
5. Click the blank **image box** and navigate to the location where images are located, choose a photo image, and click **Open**.

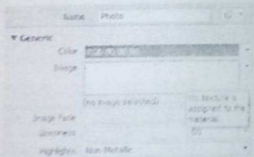

*The photo is added as an image material*



## AutoCAD 3D Tutorials

---

6. Choose

the dropdown option for **Transforms**.

7. Choose

the dropdown for **Repeat** and set the Horizontal and Vertical repeats to **None**.



8. Apply

the material to the 3D face in the drawing

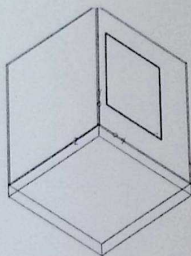

## AutoCAD 3D Tutorials

9. Render

the viewport

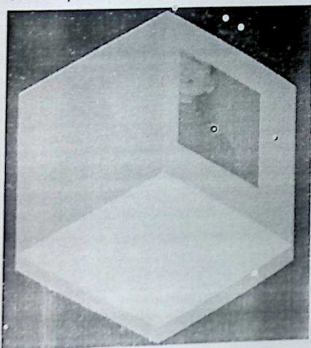

10. Edit

the material image transforms as follows.

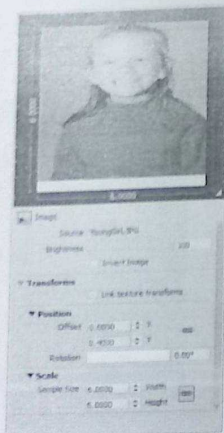

## AutoCAD 3D Tutorials

---

11. Render

the viewport.

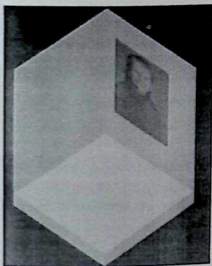

## AutoCAD 3D Tutorials

---

### 19.9 Material Mapping (Photo)

1. Type **MATERIALMAP** at the command prompt.  
Command: **MATERIALMAP**  
Select an option  
[Box/Planar/Spherical/Cylindrical/copy  
mapping to/Reset  
mapping]<Box>: **PLANAR**  
Select faces or objects: 1 found

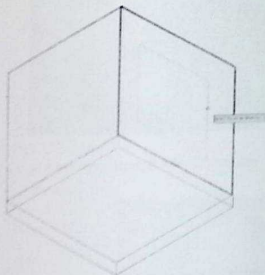

Select faces or objects: enter

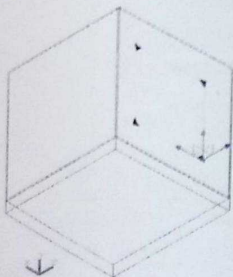

## AutoCAD 3D Tutorials

---

Accept the mapping or  
[Move/Rotate/reset/switch mapping  
mode];enter  
Regenerating model.

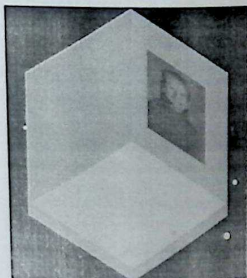

## AutoCAD 3D Tutorials

---

### 19.10 Material Mapping (Shapes)

1. Open a drawing with a box, cylinder, and sphere.
2. Attach an image material to the cylinder (for example, Wild Cherry Natural 2).
3. Type **MATERIALMAP** at the command prompt.  
Command: **MATERIALMAP**
4. Choose Cylinder and then pick the cylinder in the drawing.
5. Use the grips to move the mapping plane along the cylinder.

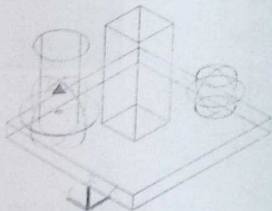

6. Press enter and render the drawing

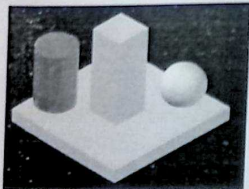

## AutoCAD 3D Tutorials

---

7. Change the material mapping again for the cylinder.

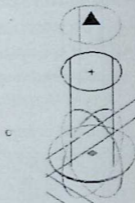

8. Render the viewport.

Practice adjusting the material map for the box and sphere

## AutoCAD 3D Tutorials

---

### 19.11 Removing Materials from Objects



1. Click

Remove Materials from the Render tab under 3D Modeling.

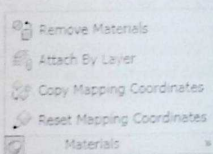



## AutoCAD 3D Tutorials

### 19.12 Cutout Materials

1. Choose **View, Render, Materials Browser...**  
or
2. Type **MATERIALS** at the command prompt.  
Command: **MATERIALS**
3. Click **Create Material** and create a new generic material called **Magnolia Tree**.
4. Click **Image** and add an image for a tree.
5. Select **Scale** and change both the width and height to **10'**.
6. Select **Repeat** and set both horizontal and vertical to **None**.
7. Click **Cutout** and select the same image as the tree as a black and white cutout.
8. Select **Scale** and change both the width and height to **10'**.
9. Select **Repeat** and set both horizontal and vertical to **None**.

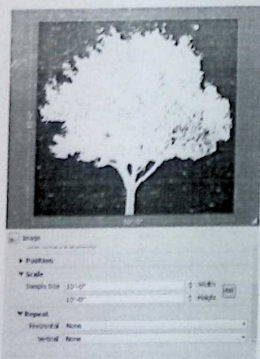
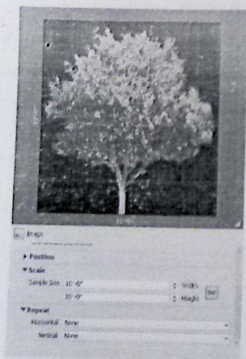

## AutoCAD 3D Tutorials

---

10. Apply the material to an object.

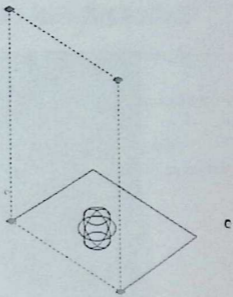

11. Set the material mapping to planar.

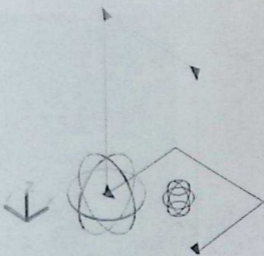

## AutoCAD 3D Tutorials

---

12. Render the viewport.

Objects should now be seen behind the cutout image.

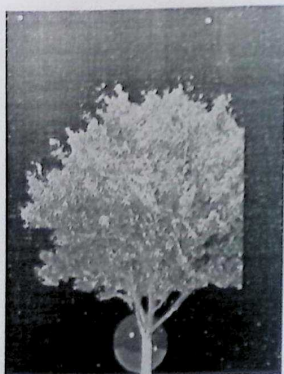
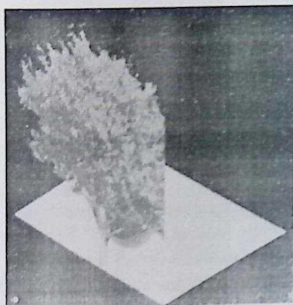

## AutoCAD 3D Tutorials

### 19.13 Bump Map Materials

1. Choose **View, Render, Materials Browser**  
or
2. Type **MATERIALS** at the command prompt.  
Command: materials
3. Click **Create Material** and create a generic material called **Bump Material**.
4. Click **Image** and add a material image.
5. Click **Bump** and add the same image as the bump material.

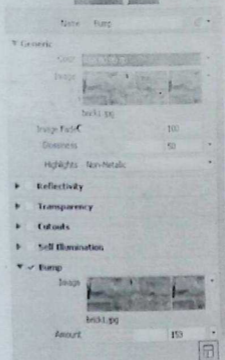

6. Apply the image to an object and set material mapping if necessary.

## AutoCAD 3D Tutorials

7. Render the viewport.

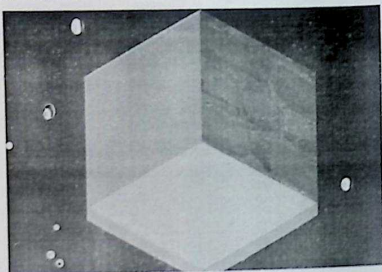

5. Adjust the bump settings and render again.

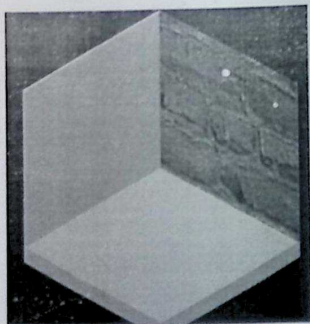
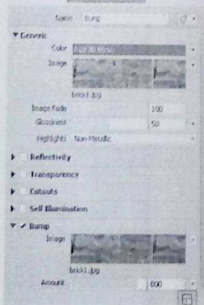

## AutoCAD 3D Tutorials

### 19.12 Materials ON/OFF

1. Open a drawing with materials and textures added.
2. Set the Visual Style to Realistic.
3. Choose Materials OFF from the Materials ribbon  
or
4. Type `VSMATERIALMODE` at the command prompt.  
Command: `_VSMATERIALMODE`  
Enter new value for VSMATERIALMODE <2>  
0  
0=Materials OFF/Textures OFF  
1= Materials ON/Textures OFF  
2=Materials ON/Textures ON

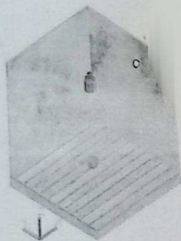
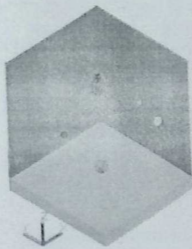
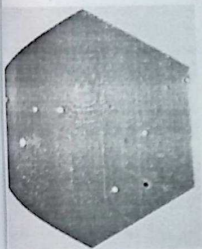

**AutoCAD 3D – Chapter 20**  
**Lights .**

## AutoCAD 3D Tutorials

### 20.1 Default Lighting

When there are no lights in a scene, the scene is shaded with default lighting. Default lighting is derived from two distant sources that follow the viewpoint as you move around the model. All faces in the model are illuminated so that they are visually discernible. You can control brightness and contrast, but you do not need to create or place lights yourself.

When you insert custom lights or add sunlight, you can disable the default lighting. You can apply default lighting to the viewport only, at the same time, you can apply custom lights to the rendering.

#### ON/OFF

1. Choose Default Lighting from the Lighting ribbon

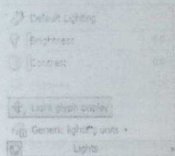

or

2. Type DEFAULTLIGHTING at the command prompt.  
Command: DEFAULTLIGHTING  
Enter new value for DEFAULTLIGHTING <0>: 1

## AutoCAD 3D Tutorials

---

### 20.2 Point Lights

A point light radiates light in all directions from its location.

1. Open a drawing with 3D objects and display in a 3D view.
2. Choose View, Render, Light, New Point Light.  
or
3. Type POINTLIGHT at the command prompt.  
Command: **POINTLIGHT**
4. Click Turn Off default lighting in the following prompt if default lighting was on:

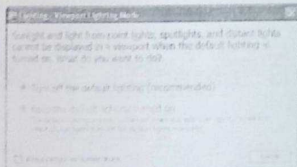

Specify source location <0,0,0>: .XY

of pick bottom center of bottle

(need Z): 15

Enter an option to change

[Name/Intensity/Status/shadow/Attenuation/Color/  
eXit] <eXit> press enter

5. Render the current viewport.

## AutoCAD 3D Tutorials

---

View rendered using a point light

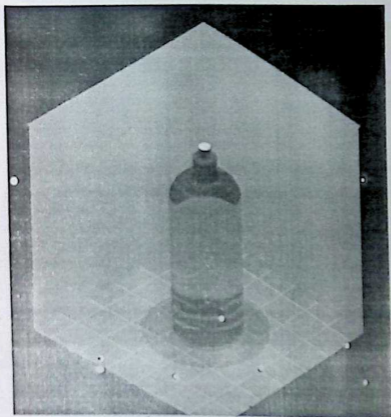

## AutoCAD 3D Tutorials

---

### 20.3 Spot Lights

A spotlight emits a directional cone of light.

1. Choose View, Render, Light, New Spot Light  
or
2. Type SPOTLIGHT at the command prompt.  
Command: SPOTLIGHT  
Specify source location <0,0,0>. P1  
Specify target location <0,0,-10>. P2  
Enter an option to change  
[Name/Intensity/Status/Hotspot/Falloff/shadow/Attenuation/Color/eXit] <eXit>: press enter

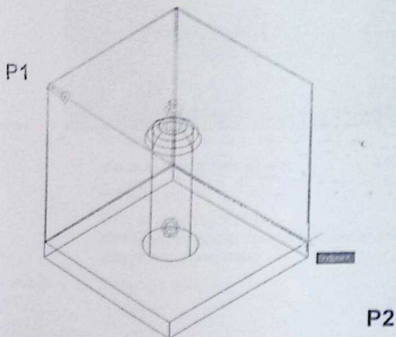

3. Render the current viewport.

## AutoCAD 3D Tutorials

---

*View rendered using a point and spotlight*

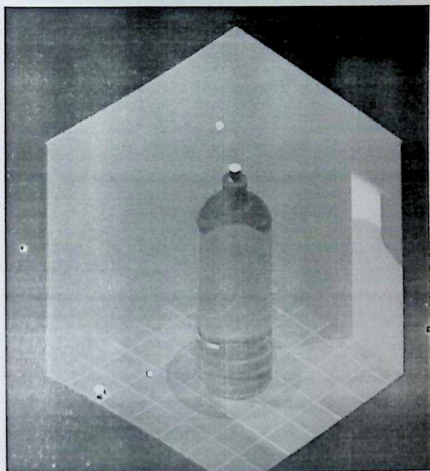

## AutoCAD 3D Tutorials

---



### 20.4 Editing Lights with Light List

The lightlist command allows you to modify lights in a drawing. This includes turning lights off, deleting lights, or changing the properties of one or more lights.

1. Open a drawing with lights.
2. Choose View, Render, Light, Lightlist.  
or
3. Type LIGHTLIST at the command prompt.

Command: LIGHTLIST

Lights in Model:

Type	Light Name
	Pointlight1
	Spotlight2

Click a light on the list to select it in the model. Use CTRL for multiple selection. Note: Distant lights and the sun do not appear as interface objects in the model.

4. Double-click the point light in the drawing to modify its properties.

## AutoCAD 3D Tutorials

General	
Name	Pointlight1
Type	Point
On/Off Status	On
Shadows	On
Intensity factor	2.0000
Filter color	<input type="checkbox"/> 255,255,255
Flat glyph	No
Glyph display	Auto
Geometry	
Position X	9.0243
Position Y	2.4496
Position Z	20.0000
Targeted	No
Attenuation	
Type	None
Use limits	No
Start limit offset	1.0000
End limit offset	10.0000
Rendered Shadow Details	
Type	Sharp
Map size	256
Softness	1

Render the viewport to see the changes to the light

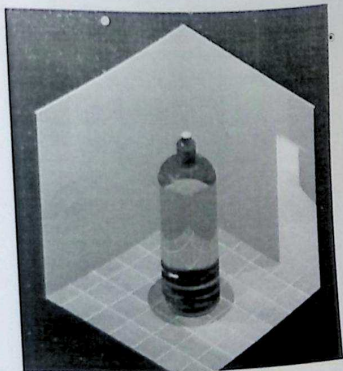

## AutoCAD 3D Tutorials

### 20.5 Photometric Lights

For more precise control over lighting, you can use photometric lights to illuminate your model. Photometric lights use photometric (light energy) values that enable you to more accurately define lights as they would be in the real world. You can create lights with various distribution and color characteristics, or import specific photometric files available from lighting manufacturers.

Photometric lights can use manufacturers' IES standard file format. By using manufacturers' lighting data, you can visualize commercially available lighting in your model. Then you can experiment with different fixtures, and by varying the light intensity and color temperature, you can design a lighting system that produces the results you want.

1. Open a drawing with lights.
2. Type LIGHTLIST to see the current lights in the drawing.

Lights in Model:

Type	Light Name
✓	Lens Spotlight
✓	Pointlight1
✓	Pointlight2
✓	Pointlight3
✓	Pointlight4

3. Render the viewport to see the current light settings with photometric lights off.

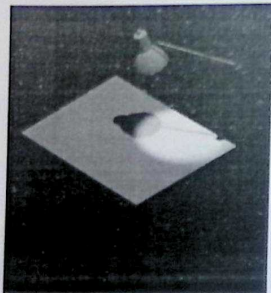

## AutoCAD 3D Tutorials

---

4. Type **LIGHTINGUNITS** at the command prompt and set its value to 1 (on).

Command: **LIGHTINGUNITS**

Enter new value for LIGHTINGUNITS <0>: 1

5. Render the viewport to see the current light settings with photometric lights on.

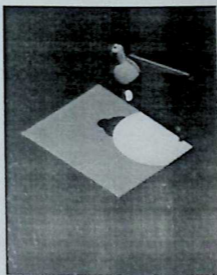

6. Type **LIGHTLIST** and double-click the Lamp Spotlight.  
7. Change the lamp color to **Halogen** and the Candela intensity to **150**.

Photometric properties	
Lamp intensity	150.000 Cd
Resulting intensity	150.000 Cd
Lamp color	<input type="checkbox"/> Halogen
Resulting color	<input type="checkbox"/> 255,247,219

8. Render the viewport.

## AutoCAD 3D Tutorials

---

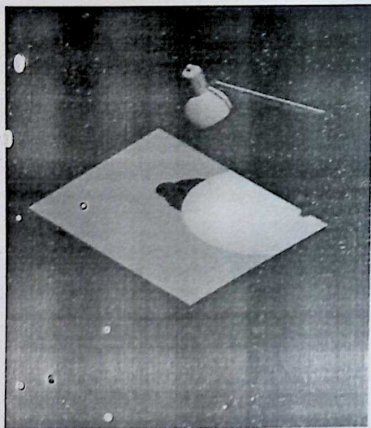

9. Practice changing other light's photometric properties.

## AutoCAD 3D Tutorials

### 20.6 Lights Tool Palette

Default lights can be added to your drawing from the Tool Palette menus.

1. Press CTRL +3 to open the Tool Palettes.
2. Right click Incandescent.

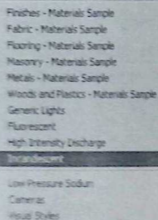

3. Right-click the 75 Watt bulb and choose properties.
4. Modify the photometric properties for this bulb.

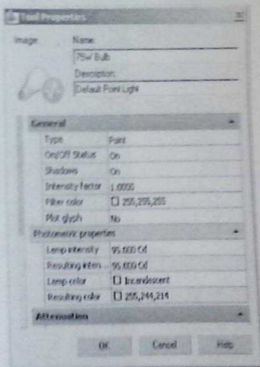

## AutoCAD 3D Tutorials

---

### 20.7 Luminaries

To create realistic lighting in a drawing, you can embed photometric lights in blocks that also contain geometry.

Tool palettes of photometric lights provide easy access to photometric lighting bulbs, lamps, or webs. You can select from fluorescent, low pressure sodium, incandescent, and high intensity discharge types of lighting.

A luminary assembles a set of light objects into a light fixture. For example, you can create a set of lights to create a light over a dining area. You can select the photometric lights from the tool palettes, position them within a 3D representation of the light, and create a block of the light objects and the 3D representation of the light to create the light fixture with photometric properties.

1. Open a drawing with photometric lights and a light fixture.
2. Create a block of the light fixture made up of the lights and fixture.
3. Insert the block in the drawing and render the viewport.

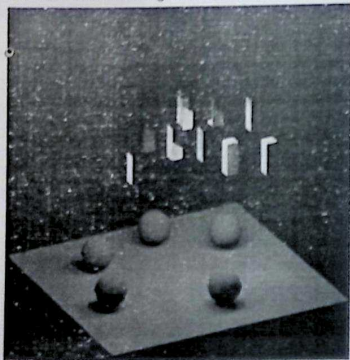

## AutoCAD 3D Tutorials

### 20.8 Distant Lights

A distant light emits uniform parallel light rays in one direction only. You specify a FROM point and a TO point anywhere in the viewport to define the direction of the light. There is no light glyph to represent a distant light in your drawing.

1. Open a drawing with 3D objects and display in a 3D view.
2. Choose View, Render, Light, New Distant Light  
or
3. Type DISTANTLIGHT at the command prompt.  
Command: **DISTANTLIGHT**  
Specify light direction FROM <0,0,0> or [Vector]: .XY  
of MID P1  
of (need Z): 5  
Specify light direction TO <1,1,1>: .XY  
of MID P2  
of (need Z): 5  
Enter an option to change  
[Name/Intensity/Status/shadoW/Color/eXit] <eXit>  
**enter**

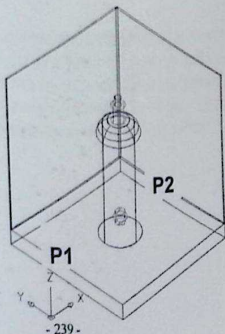

## AutoCAD 3D Tutorials

---

*View rendered using a point and distant light*

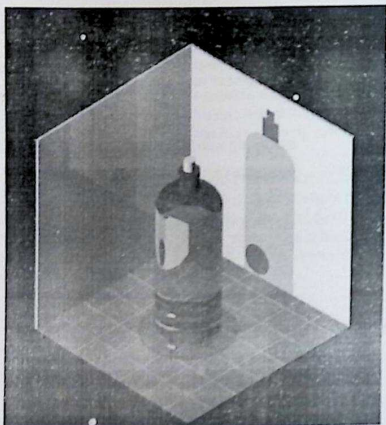

## AutoCAD 3D Tutorials

---

### 20.9 Other Lights

#### Weblights

Photometric weblights provide real-world light distribution.

A photometric weblight (web) is a 3D representation of the light intensity distribution of a light source. Photometric weblights can be used to represent anisotropic (non-uniform) light distributions derived from data provided by manufacturers of real-world lights. This gives a far more precise representation of the rendered light than either spot or point lights are capable of.

This directional light distribution information is stored in a photometric data file in the IES format using the IES LM-63-1991 standard file format for photometric data. You can load photometric data files provided by various manufacturers under the Photometric Web panel in the Properties palette for the light. The light icon represents the photometric web you select.

Light that uses a photometric web can be added to a drawing by entering the commands `WEBLIGHT` and `FREEWEB` at the command prompt. A weblight targets an object whereas a freeweb light does not.

#### Target Point Lights

You create a target point light with the `TARGETPOINT` command. The difference between the target point light and a point light is the additional target properties that are available. A target light can be pointed to an object. A target point light can also be created from a point light by changing the target property of the point light from No to Yes.

## AutoCAD 3D Tutorials

### 20.10 Geographic Locations

Specifies the latitude and longitude of a location for the sunlight.

1. Open a drawing with a known geography and lights.
2. Choose View, Render, Light, Geographic Location.  
or
3. Type GEOGRAPHICLOCATION at the command prompt.  
Command: GEOGRAPHICLOCATION
4. Choose **Enter the location values** from the following dialog box.

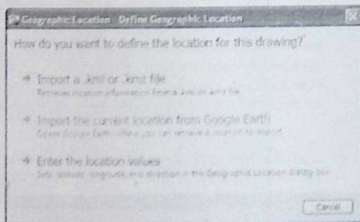

5. Click the **Use Map...** button.

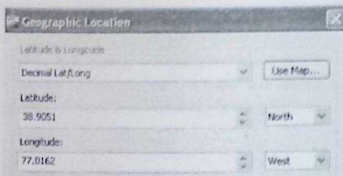

## AutoCAD 3D Tutorials

6. Choose Washington, D.C from the location dialog box.

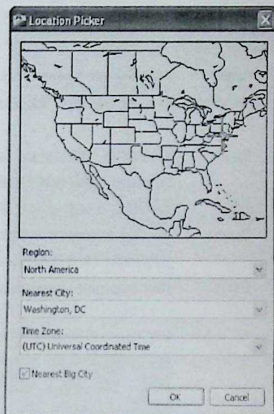

7. Accept the updated time zone settings.

## AutoCAD 3D Tutorials

---

### 20.11 Sun Properties

1. Open a drawing with a geographic location identified.
2. Choose View, Render, Light, Sun Properties.  
or
3. Type SUNPROPERTIES at the command prompt.  
Command: **SUNPROPERTIES**
4. Click the Status dropdown and click **ON**.
5. Change the date to **November 2 2010**  
(or the next election date).
6. Change other properties as desired and render the model.

*US Capitol Building rendered*

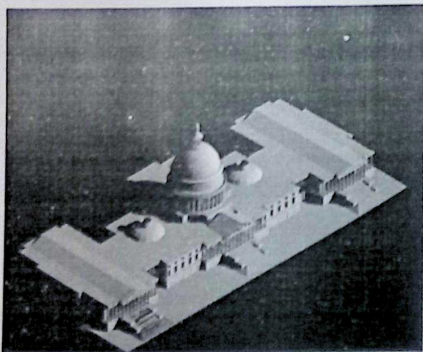

o **AutoCAD 3D – Chapter 21  
Render Environments and  
Background**

## AutoCAD 3D Tutorials

### 21.1 Render Environment

You can use environmental features to set up atmospheric effects or background images.

1. Open a drawing with 3D objects and display in a 3D view.
2. Choose View, Render, Advanced Render Environment...  
or
3. Type RENDERENVIRONMENT at the command prompt.  
Command: RENDERENVIRONMENT
4. Select Enable Fog On and set the following near and far percents.

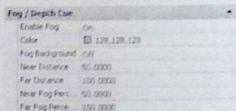

Before fog

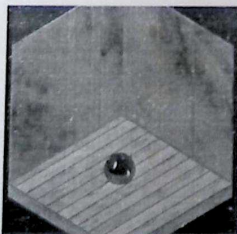

After fog

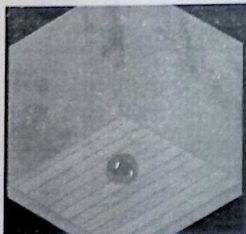

## AutoCAD 3D Tutorials

### 21.2 Solid Background

A background is a backdrop that displays behind your model. Backgrounds can be a single color, a multi-color gradient, or a bitmap image.

1. Open a drawing with 3D objects and display in a 3D view.
2. Choose View, Named Views.  
or
3. Type VIEW at the command prompt.  
Command: VIEW
4. Choose New...
5. Type a name for your new view.
6. Click the drop down box under background and choose Solid.
7. Choose a color for your solid background.

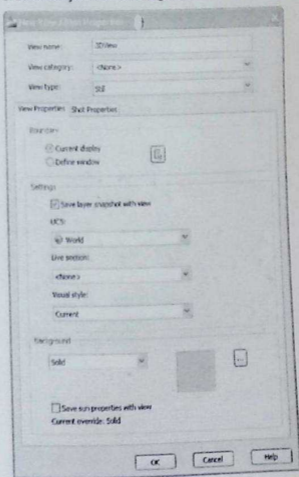

## AutoCAD 3D Tutorials

---

8. Set the new view to be the current view.
8. Render the viewport.

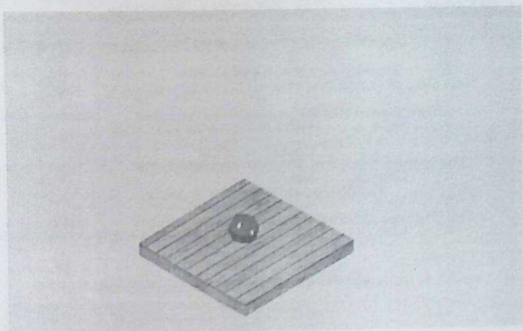

## AutoCAD 3D Tutorials

---

### 21.3 Gradient Environment

1. Open a drawing with 3D objects and display in a 3D view.
2. Choose View, Named Views.  
or
3. Type VIEW at the command prompt.  
Command: VIEW
4. Choose New...
5. Type a name for your new view.
6. Click the check box beside background.
7. Choose the dropdown option for background type and choose gradient.
8. Choose Colors for your gradient background

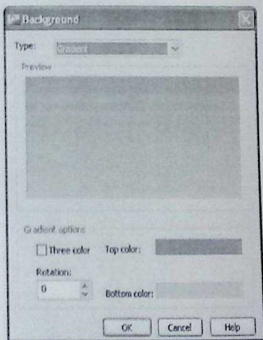

## AutoCAD 3D Tutorials

9. Set the new view to be current.

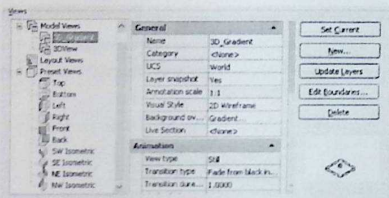

10. Render the viewport.

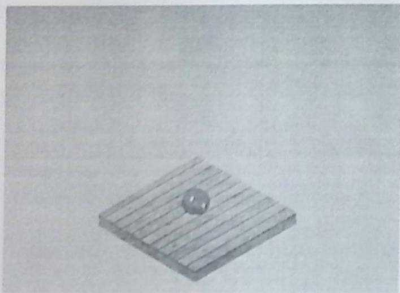

## AutoCAD 3D Tutorials

### 21.4 Image Background

1. Open a drawing with 3D objects and display in a 3D view.
2. Choose View, Named Views.  
or
3. Type VIEW at the command prompt.  
Command: VIEW
4. Choose New...
5. Type a name for your new view.
6. Click the check box beside background.
7. Choose the dropdown option for background type and choose image.
8. Click the Browse button and choose an image for your background.

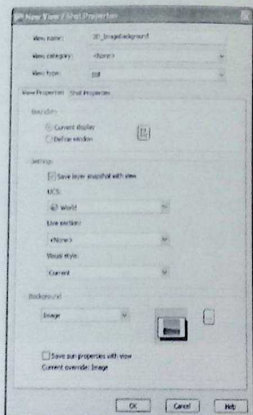

## AutoCAD 3D Tutorials

9. Set the new view to be the current view.

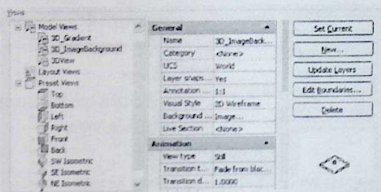

10. Render the viewport.

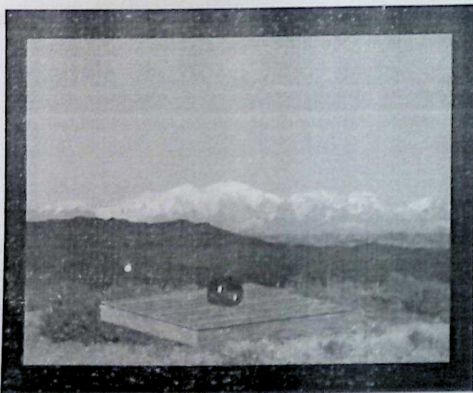

**AutoCAD 3D – Chapter 22**  
**Advanced Render Commands**

## AutoCAD 3D Tutorials

---

### 22.1 Materials

Contains settings that affect how materials are handled by the renderer.

#### Apply Materials

Applies the surface materials that you define and attach to an object in the drawing. If Apply Materials is not selected, all objects in the drawing assume the color, ambient, diffuse, reflection, roughness, transparency, refraction, and bump map attribute values defined for the GLOBAL material.

#### Texture Filtering

Specifies how texture maps are filtered.

#### Force 2-Sided

Controls if both sides of faces are rendered.

1. Open a drawing with 3D objects and display in a 3D view.
2. Choose View, Render, Advanced Render Settings...  
or
3. Type RPREF at the command prompt.  
Command: RPREF

Materials ▲	
Apply materials	On
Texture filtering	On
Force 2-sided	On

## AutoCAD 3D Tutorials

### 22.2 Sampling

Controls how the renderer performs sampling.

1. Type `RPREF` at the command prompt.

Command: `RPREF`

Sampling	
Min samples	1
Max samples	16
Filter type	Mitchell
Filter width	4.0000
Filter height	4.0000
Contrast color	0.0500, 0.0500, 0.0500, 0.0500
Contrast red	0.0500
Contrast blue	0.0500
Contrast green	0.0500
Contrast alpha	0.0500

#### Min Samples

Sets the minimum sample rate. The value represents the number of samples per pixel. A value greater than or equal to 1 indicates that one or more samples are computed per pixel. A fractional value indicates that one sample is computed for every N pixels (for example, 1/4 computes a minimum of one sample for every four pixels). Default=1/4.

#### Max Samples

Sets the maximum sample rate. If neighboring samples find a difference in contrast that exceeds the contrast limit, the area containing the contrast is subdivided to the depth specified by Maximum. Default=1.

The values of the Min Samples and Max Samples lists are "locked" together so that the value of Min Samples can't exceed the value of Max Samples. An error dialog box is displayed if the Min Samples value is greater than the Max Samples value.

## AutoCAD 3D Tutorials

---

### Filter Type

Determines how multiple samples are combined into a single pixel value. The filter types are:

- |                 |   |
|-----------------|---|
| <b>Box</b>      | Sums all samples in the filter area with equal weight. This is the quickest sampling method.  |
| <b>Gauss</b>    | Weights the samples using a Gauss (bell) curve centered on the pixel.   |
| <b>Triangle</b> | Weights the samples using a pyramid centered on the pixel.  |
| <b>Mitchell</b> | Weights the samples using a curve (steeper than Gauss) centered on the pixel.   |
| <b>Lanczos</b>  | Weights the samples using a curve (steeper than Gauss) centered on the pixel, diminishing the effect of samples at the edge of the filter area. |

### Filter Width and Filter Height

Specifies the size of the filtered area. Increasing the value of Filter Width and Filter Height can soften the image; however, it will increase rendering time.

### Contrast Color

Clicking [...] opens the Select Color dialog box where you interactively specify the R,G,B threshold values.

### Contrast Red, Blue, Green

Specifies the threshold values for the red, blue, and green components of samples. These values are normalized, and range from 0.0 to 1.0, where 0.0 indicates the color component is fully

## **AutoCAD 3D Tutorials**

---

unsaturated (black, or 0 in eight-bit encoding) and 1.0 indicates the color component is fully saturated (white, or 255 in eight-bit encoding).

### **Contrast Alpha**

Specifies the threshold value for the alpha component of samples. This value is normalized, and ranges from 0.0 (fully transparent, or 0 in eight-bit encoding) to 1.0 (fully opaque, or 255 in eight-bit encoding).

## AutoCAD 3D Tutorials

### 22.3 Shadows

Contains settings that affect how shadows appear in the rendered image.

1. **Type** RPREF at the command prompt.

Command: **rpref**

Shadows	
Mode	Simple
Shadow map	Off
Sampling Multiplier	1

#### Enable

Specifies if shadows are computed during rendering.

#### Mode

The shadow mode can be Simple, Sort, or Segments.

**Simple.** Generates shadow shaders in a random order.

**Sort.** Generates shadow shaders in order, from the object to the light.

**Segments.** Generates shadow shaders in order along the light ray from the volume shaders to the segments of the light ray between the object and the light.

#### Shadow Map

Controls if shadow mapping is used to render shadows. When on, the renderer renders shadow-mapped shadows. When off, all shadows are ray-traced.

#### Sampling Multiplier

Globally limits shadow sampling for area lights. This is part of the rendering preset data. This allows draft and low quality presets to reduce area light sampling. It's effect is to modulate the inherent sampling frequency specified for each light. The default value=1 for new presets. Values are 0, 1/8, 1/4, 1/2, 1, 2. Draft: 0; Low: 1/4; Med: 1/2; High: 1; Presentation: 1.

## AutoCAD 3D Tutorials

---

### 22.4 Ray Tracing

Contains settings that affect the shading of a rendered image.

1. Type RPREF at the command prompt.  
Command: RPREF

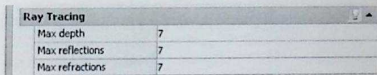

Ray Tracing	
Max depth	7
Max reflections	7
Max refractions	7

#### Enable

Specifies if ray tracing should be performed when shading

#### Max Depth

Limits the combination of reflection and refraction. Tracing of a ray stops when the total number of reflections and refractions reaches the maximum depth. For example, if Max Depth equals 3 and the two trace depths each equal the default value of 2, a ray can be reflected twice and refracted once, or vice versa, but it cannot be reflected and refracted four times.

#### Max Reflections

Sets the number of times a ray can be reflected. At 0, no reflection occurs. At 1, the ray can be reflected once only. At 2, the ray can be reflected twice, and so on.

#### Max Refractions

Sets the number of times a ray can be refracted. At 0, no refraction occurs. At 1, the ray can be refracted once only. At 2, the ray can be refracted twice, and so on.

## AutoCAD 3D Tutorials

### 22.5 Illumination

Affects how your scene is illuminated.

1. Type `RPREF` at the command prompt.

Command: `rpref`

Indirect Illumination	
Global Illumination	
Photons/sample	500
Use radius	Off
Radius	1.0000
Max depth	5
Max reflections	5
Max refractions	5
Final Gather	
Mode	Auto
Rays	500
Radius mode	Off
Max radius	1.0000
Use min	Off
Min radius	0.1000
Light Properties	
Photons/light	10000
Energy multiplier	1.0000

Enable

Specifies if lights should cast indirect light into the scene.

Photons/Samples

Sets how many photons are used to compute the intensity of the global illumination. Increasing this value makes global illumination less noisy but also more blurry. Decreasing this value makes global illumination more noisy but less blurry. The larger the Samples value, the greater the rendering time.

Use Radius

Determines the size of photons. When on, the spinner value sets the size of photons. When off, each photon is calculated to be 1/10 of the radius of the full scene.

## AutoCAD 3D Tutorials

---

### Radius

Specifies the area within which photons will be used when illuminance is computed.

### Max Depth

Limits the combination of reflection and refraction. Reflection and refraction of a photon stop when the total number of both equals the Max Depth setting. For example, if Max Depth equals 3 and the trace depths each equal 2, a photon can be reflected twice and refracted once, or vice versa, but it can't be reflected and refracted four times.

### Max Reflections

Sets the number of times a photon can be reflected. At 0, no reflection occurs. At 1, the photon can be reflected once only. At 2, the photon can be reflected twice, and so on.

### Max Refractions

Sets the number of times a photon can be refracted. At 0, no refraction occurs. At 1, the photon can be refracted once only. At 2, the photon can be refracted twice, and so on.

## AutoCAD 3D Tutorials

---

### 22.6 Diagnostic

Helps you understand why the renderer is behaving in a certain way.

1. Type RPREF at the command prompt.

Command: RPREF

Diagnostic	
Visual	
Grid	Off
Grid size	10.0000
Photon	Off
Samples	Off
BSP	Off

- Grid** Renders an image that shows the coordinate space of objects, the world, or camera.
- Object** Shows local coordinates (UWV). Each object has its own coordinate space.
- World** Shows world coordinates (XYZ). The same coordinate system applies to all objects.
- Camera** Shows camera coordinates, which appear as a rectangular grid superimposed on the view.
- Grid Size** Sets the size of the grid.
- Photon** Renders the effect of a photon map. This requires that a photon map be present. If no photon map is present, the Photon rendering looks just like the nondiagnostic rendering of the scene: the renderer first renders the shaded scene, then replaces it with the pseudocolor image.
- Density.** Renders the photon map as it is projected into the scene. High density is displayed in red, and lower values render in increasingly cooler colors.
- Irradiance.** Similar to the Density rendering, but shades the photons based on their irradiance. The maximum irradiance is rendered in red, and lower values render in increasingly cooler colors.
- BSP** Renders a visualization of the parameters used by the tree in the

## **AutoCAD 3D Tutorials**

---

BSP ray-trace acceleration method. If a message from the renderer reports excessively large depth or size values, or if rendering seems unusually slow, this can help you locate the problem.

- Depth.** Shows the depth of the tree, with top faces in bright red, and increasingly deep faces in increasingly cool colors.
- Size.** Shows the size of leaves in the tree, with differently sized leaves indicated by different colors.

100.000

## AutoCAD 3D Tutorials

### 22.7 Processing

1. Type RPREF at the command prompt

Command: RPREF

Processing	
Tile size	32
Tile order	Hilbert
Memory limit	1048

**Tile Size** Determines the tile size for rendering. To render the scene, the image is subdivided into tiles. The smaller the tile size, the more image updates are generated during rendering. When the tile size is reduced, the number of image updates increases, meaning that a rendering take longer to complete. If the tile size is increased, fewer image updates occur and the rendering takes less time to complete.

**Tile Order** Specifies the method used (render order) for tiles as an image is rendered. You can choose a method based on you prefer to see the image appear as it renders in the Render Window.

**Hilbert.** Next tile to be rendered is based on the cost of switching to the next one.

**Spiral.** Tiles are rendered beginning at the center of the image, and spiral outward.

**Left to Right.** Tiles are rendered in columns, from bottom to top, left to right

**Right to Left.** Tiles are rendered in columns, from bottom to top, right to left

**Top to Bottom.** Tiles are rendered in rows, from right to left, top to bottom

**Bottom to Top.** Tiles are rendered in rows, from right to left, bottom to top.

**Memory Limit** Determines the memory limit for rendering. The renderer keeps a count of the memory it uses at render time. If the memory limit is reached, the geometry for some objects is discarded in order to allocate memory for other objects.