

O.S. ABLYALIMOV

TERMODINAMIKA

I QISM

**«O‘ZBEKISTON TEMIR YO‘LLARI»
AKSIYADORLIK JAMIYATI
O‘ZBEKISTON RESPUBLIKASI OLIY VA
O‘RTA MAXSUS TA‘LIM VAZIRLIGI
TOSHKENT TEMIR YO‘L MUHANDISLARI INSTITUTI**

O.S. ABLYALIMOV

TERMODINAMIKA

*5310600 – Yer usti transport tizimlari va ularning ekspluatatsiyasi
(lokomotivlar), 5111000 – Kasb ta’limi (5310600 – Yer usti transport
tizimlari va ularning ekspluatatsiyasi (lokomotivlar) ta’lim yo‘nalishlari
2, 3 - bosqich bakalavriat talabalari uchun masalalar to‘plami*

I QISM

«O‘zbekiston xalqaro islom akademiyasi»
nashriyot-matbaa birlashmasi
Toshkent – 2020

UO‘K: 621.43.016(075.8)

KBK: 31.31ya73

A 17

Ablyalimov, O.S.

Termodinamika [Matn] : o‘quv qo‘llanma / O.S.Ablyalimov. – Toshkent : «O‘zbekiston xalqaro islom akademiyasi» nashriyot-matbaa birlashmasi, 2020. – 192 b.

UO‘K: 621.43.016(075.8)

KBK: 31.31ya73

Taqrizchilar:

Bazarov B. I. – *texnika fanlari doktori, professor,
Toshkent avtomobil yo‘llarini loyihalash, qurilish va
eksploatatsiya instituti «Ekologiya va IYOD» kafedrasini mudiri*

Rizayev A. N. – *texnika fanlari doktori, professor,
Toshkent temiryo‘l muhandislari instituti
«Muhandislik kommunikatsiyasi va tizimlari» kafedrasini mudiri*

O‘quv qo‘llanmada texnik termodinamika asoslari va issiqlik almashinuvi nazariyalari haqida qisqacha ma’lumot berilgan. Shuningdek, olingan mavzular bo‘yicha formulalar va ularga doir misollar ko‘rsatilgan. Barcha misollar yechimga ega va namunaviy misollar yechimi bilan ko‘rsatilgan. Misollarni yechish uchun kerakli materiallar berilgan, bu materiallar amaliy mashg‘ulotlar jarayonida foydali bo‘lishi mumkin, shuningdek oraliq va yakuniy nazorat ishi singari imtihonlarda va talabalar tomonidan bajariladigan mustaqil loyiha hisob ishlarida qo‘llanilishi mumkin.

O‘quv qo‘llanma oliy o‘quv yurtlarida tahsil olayotgan, issiqlik energiyasiga doir bo‘lmagan mutaxassislikda o‘qiyotgan, shuningdek, temiryo‘lchilar va issiqlik energiyasini o‘rganayotganlar uchun mo‘ljallangan. Bundan tashqari oliy texnik o‘quv yurtlari o‘qituvchilariga, muhandislarga, texnik ishchilarga va ilmiy xodimlarga, shuningdek, issiqlik energiyasi mutaxassislari uchun ham foydali bo‘lishi mumkin.

O‘quv qo‘llanma O‘zbekiston Respublikasi Oliy va o‘rta maxsus ta’lim va zirligining 2020-yil 30-iyundagi 359-sonli buyrug‘iga asosan nashr etishga ruxsat berilgan.

ISBN 978-9943-6529-6-5

© «O‘zbekiston xalqaro islom akademiyasi»
nashriyot-matbaa birlashmasi, 2020.

© O.S. Ablyalimov, 2020.

SO‘Z BOSHI

«Texnikaviy termodinamika» va «Issiqlik va massa uzatish asoslari» bo‘limlari uchun vazifalar to‘plami «Termodinamika» 5310600 – «Yer usti transport tizimlari va ularning ekspluatatsiyasi (lokomotivlar va vagonlar)» va 5111000 – Kasbiy ta‘lim (5310600 – «Yer usti transport tizimlari va ularning ekspluatatsiyasi (lokomotivlar va vagonlar)») va oliy o‘quv yurtlarining nodavlat-ixtisosliklari talabalari uchun o‘qitish vositasi sifatida mo‘ljallangan.

Texnikaviy termodinamika, issiqlik va massa o‘tkazish, issiqliklarni olish va konvertatsiya qilish usullari, shuningdek, issiqlik va elektr stansiyalarining ishlatish va loyihalash tamoyillarini o‘rganish bo‘yicha umumiy texnika qo‘llanmasi bo‘lib foydalaniladi. Ushbu kursning maqsadi sanoat, transport va qishloq xo‘jaligida keng qo‘llaniladigan issiqlik va energetika uskunalari yetkazib berish bo‘yicha mutaxassislarni tayyorlashdir.

Bu masalalar to‘plami (o‘quv qo‘llanma) noenergetik mutaxassislikda tahsil oluvchi oliy o‘quv yurtlari talabalari uchun mo‘ljallangan. Bundan tashqari oliy texnik o‘quv yurtlari o‘quvchilariga, muhandislariga, texnik ishchilarga va ilmiy xodimlarga, shuningdek, issiqlik energiyasi mutaxassislari uchun ham foydali bo‘lishi mumkin.

Tekshirish vazifalaridan tashqari darslik qisqacha nazariy fanni tavsiflaydi va ular uchun asosiy hisoblash formulalarini va tushuntirishlarini beradi. Tekshirish vazifalari javoblarga ega va tipik, odatiy va murakkab vazifalar batafsil yechimlar bilan berilgan. Muammoni hal qilish uchun suv va suv bug‘larining jadvallari, ma‘lumotlar va grafik bog‘liqliklar shaklidagi termal xususiyatlariga oid materiallar berilgan.

Texnika fanlari doktori, professor B. I. Bazarov (TAYLQ va EI), texnika fanlari doktori professor A. N. Rizayev (TTYMI), PhD, dotsent, ToshDTU «Termodinamika va issiqlik texnikasi» kafedra mudiri A. S. Isaxojayev, ToshDTU «Termodinamika va issiqlik texnikasi» kafedrasida katta o‘qituvchisi L. O. Alimova qo‘lyozmani diqqat bilan o‘qiganligi, foydali maslahatlar va qo‘lyozmani ko‘rib chiqishda ular tomonidan tuzilgan o‘quv qo‘llanmaning tarkibi va mazmunini yaxshilash bo‘yicha qimmatli izohlari va o‘quv ustasi V. V. Agapovga ushbu jarayonda ko‘rsatgan yordami uchun minnatdorlik bildiramiz.

Muallif

ASOSIY SHARTLI BELGILAR

- T – absolyut harorat, (K) °K;
 t – muzning erish nuqtasidan hisoblanadigan harorat, °C.
 Δt – haroratlar farqi, °C;
 ρ – zichlik, kg/m³;
 v – solishtirma hajm, m³/kg;
 V – hajm, m³;
 m – massa, kg;
 p – bosim, Pa (N/m²), kPa, MPa; bar;
 Δp – bosimlar farqi, Pa (N/m²), kPa, MPa;
 R – gaz doimiysi, /(kg·°K);
 μ – molekulyar massa, kg/kmol;
 c – solishtirma issiqlik sig‘imi, kJ/(kg·°K);
 c^1 – solishtirma hajmiy issiqlik sig‘imi, kJ/(m³·°K);
 μc – molyar issiqlik sig‘imi, kJ/(kmol·°K);
 q – solishtirma issiqlik miqdori, J/kg;
 Q – issiqlik miqdori, J;
 ℓ – ish, J/kg;
 u – ichki energiya, J/kg;
 Δu – ichki energiyaning o‘zgarishi, J/kg;
 i – solishtirma entalpiya, J/kg;
 Δi – entalpiyaning o‘zgarishi, J/kg;
 s – entropiya, J/(kg·°K);
 Δs – entropiyaning o‘zgarishi, J/(kg·°K);
 r – bug‘ hosil qilish issiqligi, kJ/kg;
 d – namlik miqdori, g/kg quruq havo;
 ϕ – nisbiy namlik, %;
 B – yoqilg‘i sarfi, kg/ik;
 b – yoqilg‘ining solishtirma sarfi, kg/(kVt·s);
 D – bug‘ unumdorligi, kg/ik (ik – ikkita);
 Q_q, Q_{yu} – yoqilg‘ining quyi va yuqori yonish issiqligi, kJ/kg;
 ε – sovutish koeffitsiyenti, siqilish darajasi;
 η_t – termik f.i.k.;
 χ – issiqlik o‘tkazuvchanlik koeffitsiyenti, Vt/(m·°K);
 α – issiqlik berish koeffitsiyenti, Vt/(m²·°K);
 k – issiqlik uzatish koeffitsiyenti, Vt/(m²·°K);
 N – quvvat, kVt.

1-BOB. TEXNIK TERMODINAMIKA

1.1. Ishchi jism holatining termik parametrlari.

Ideal gazlar holatining asosiy qonunlari va tenglamalari

Termodinamik holat parametrlari tushunchasiga mutlaq (absolyut) bosim (p), solishtirma hajm (v) va mutlaq harorat (T) kiradi.

Termodinamik parametrlar holatning $f(p, v, T) = 0$ ko'rishdagi termik tenglamasi tarkibiga kiradi va bevosita o'lchanishi mumkin.

Mutlaq bosim

Bosim – yuzaga tik ta'sir qilayotgan kuchning (uning normal tarkibiy qismi) ana shu yuzga maydoniga nisbati bilan belgilanadigan kattalikdir.

$$p = \frac{F}{S} \quad (1.1)$$

bu yerda p – bosim, Pa; F – kuch, N; S – maydon, m^2 .

Hisob-kitoblarda bir paskalga karrali (bo'linadigan) kattaliklardan foydalanadilar:

1 kPa = 10^3 Pa; 1 MPa = 10^6 Pa; 1 GPa = 10^9 Pa;

1 bar = 10^5 Pa = 100 kPa,

bu yerda bosimni o'lchash birliklari quyidagi tarzda o'qiladi: kPa – kilopaskal; MPa – megapaskal; GPa – gigapaskal.

Bosimni o'lchash texnikasida 1 sm^2 maydonga ta'sir qilayotgan 1 kgs kuchga teng bo'lgan texnik atmosferani qo'llaydilar.

$$1 \text{ at} = 1 \text{ kgs} / \text{sm}^2.$$

Kichik bosimlarni o'lchash uchun suyuqlik (suv, simob, spirt va sh.k.) ustuni balandligidan foydalanadi. Suyuqlik ustuni o'z og'irligi bilan asosga bosim o'tkazadi:

$$p = \rho \cdot g \cdot h, \quad (1.2)$$

(1.2) formuladan quyidagisi kelib chiqadi:

$$h = p / (\rho \cdot g) \quad (1.3)$$

bu yerda p – bosim, Pa;

ρ – suyuqlik zichligi, kg / m^3 ;

$g = 9,80665 \approx 9,81 \text{ m} / \text{s}^2$ – erkin tushish tezlanishi.

Masalan, suv uchun ($\rho_{\text{H}_2\text{O}} = 1000 \text{ kg} / \text{m}^3$) 1 Pa quyidagiga teng:

$$h_{\text{H}_2\text{O}} = \frac{p}{\rho_{\text{H}_2\text{O}} \cdot g} = \frac{1}{10^3 \cdot 9,81} = 1,02 \cdot 10^{-4} \text{ m suv ust.} = 0,102 \text{ mm suv ust.},$$

Bu yerda bosim o‘lchov birliklari belgilari quyidagi tarzda o‘qiladi:

m suv ust. – suv ustuni metrlari;

mm suv ust. – suv ustuni millimetrlari.

Bosim p ni yoki bosimlar farqi Δp ni aniqlashda modda zichligining haroratga bog‘liqligini hisobga olish va suyuqlik ustunining 0°C haroratga balandligini quyidagi formula bo‘yicha keltirish bo‘ladi:

$$h_0 = h \cdot (1 - \beta \cdot t) \quad (1.4)$$

bu yerda h_0 – asbob ko‘rsatkichlari, 0°C ga keltirilgan, m yoki mm ;

h – ushbu haroratda suyuqlik ustuni balandligi, m yoki mm ;

β – suyuqlikning hajmiy kengayish koeffitsiyenti, K^{-1} (simob uchun $\beta = 0,000172 \text{ K}^{-1}$);

t – suyuqlik harorati, $^\circ\text{C}$.

Bosim o‘lchov birliklarini o‘tkazish 1.1-jadvalda keltirilgan.

Termodinamik hisob - kitoblarda atmosfera bosimi, ortiqcha (manometrik) bosim, siyraklashish (vakuum) va mutlaq bosimni farqlaydilar. Bunda normal atmosfera bosimi sifatida dengiz sathi darajasidagi $t = 0^\circ\text{C}$ haroratdagi havo ust. 760 mm sim. ust. ga teng bo‘lgan havo bosimini qabul qiladilar.

Bosim o'lchov birliklarini o'tkazish

Birlik	Bar	Paskal, Pa (N / m ²)	Fizik atmosfera, atm	Mexanik atmosfera, at (kgs / sm ²)	Simob ustuni mil- limetrlari, mm sim. ust.	Suv ustuni mil- limetrlari, mm suv ust.
1 bar	1	10 ⁵	0,987	1,02	750	10200
1 Pa	10 ⁻⁵	1	-	-	-	0,10
1 atm	1,013	101300	1	1,033	760	10330
1 at	0,981	98100	0,968	1	735,6	10000
1 mm sim. ust.	0,00133	133,3	0,001316	0,00136	1	13,6
1 mm suv. ust.	9,81·10 ⁻⁵	9,81	9,68·10 ⁻⁵	10 ⁻⁴	0,0736	1

Termodinamikada holat parametrlari bo'lib, asosan, mutlaq bosim ishlatiladi p , Pa .

Texnikada qo'llanadigan asboblarda, odatda, mutlaq bosimni emas, balki bosimlar – idishdagi bosim va atmosfera havosi bosimi o'rtasidagi farqni o'lchaydilar.

Idishdagi bosim atmosfera bosimidan katta bo'lsa, mutlaq bosim quyidagi formula bo'yicha hisoblab topiladi:

$$p = p_{\text{bar}} + p_{\text{m}}, \quad (1.5)$$

bu yerda p_{bar} – barometrik bosim;

p_{m} – manometrik bosim yoki ortiqcha bosim.

Shunga o'xshash tarzda, idishdagi bosim atmosfera bosimidan past bo'lganida vakuum yoki siyraklashgan havo o'lchanadi va bu holda mutlaq bosim quyidagiga teng bo'ladi:

$$p = p_{\text{bar}} - p_{\text{vak}}, \quad (1.6)$$

bu yerda p_{vak} – vakuummetrik bosim yoki havoning siyraklanishi deb atiladi.

Mutlaq harorat

Harorat jismning qiziganlik yoki sovuq darajasini tavsiflaydigan kattalikdir.

Bugungi kunda muhandislik hisob-kitoblari amaliyotida ikki xil harorat shkalasi keng tarqalgan:

1. Mutlaq harorat – suvning uchta nuqtasiga ega bo‘lgan haroratlarning termodinamik shkalasi (suv bir vaqtning o‘zida uchta fazaviy holatda bo‘ladi) $t = 0,01\text{ }^{\circ}\text{C}$ ($T = 273,16\text{ }^{\circ}\text{K}$) va $p = 610\text{ Pa}$ bo‘lganida. Harorat Kelvin shkalasiga binoan o‘lchanadi, $^{\circ}\text{K}$. Hisobning boshlanishi $T = 0\text{ }^{\circ}\text{K} = -273,15\text{ }^{\circ}\text{C}$.

2. Xalqaro amaliy haroratlar shkalasi (MPSHT) ikki xil emperik nuqtasiga ega: birinchi nuqta – muzning erish, suvning muzlash nuqtasi $t_1 = 0\text{ }^{\circ}\text{C}$ va $p = 760\text{ mm sim. ust.}$; ikkinchi nuqta – suvning qaynash nuqtasi $t_2 = 100\text{ }^{\circ}\text{C}$ va bosim $p = 760\text{ mm sim. ust}$ teng bo‘lgani qabul qilingan. MPSHT haroratni o‘lchash uchun Selsiy graduslari qo‘llanadi, $^{\circ}\text{C}$.

Haroratni termodinamik shkaladan haroratlarning amaliy shkalasiga o‘tkazish va ortga qaytarishni quyidagi formula orqali amalga oshirish mumkin:

$$T = t + 273,15\text{ }^{\circ}\text{K}; \quad (1.7)$$

$$t = T - 273,15\text{ }^{\circ}\text{C}. \quad (1.8)$$

Termodinamik parametr – mutlaq harorat, kelvinlarda ifodalanadi, $^{\circ}\text{K}$.

Solishtirma hajm

Jismning massa birligiga teng bo‘lgan hajmda solishtirma hajm deyiladi:

$$v = \frac{1}{\rho}; v = \frac{V}{m}; \quad (1.9)$$

bu yerda v – solishtirma hajm, m^3 / kg ;

V – hajm, m^3 ;

m – modda massasi, kg .

Zichlik ρ – solishtirma hajmga teskari bo‘lgan kattalikdir:

$$\rho = \frac{1}{v}; \rho = \frac{m}{V}; \quad (1.10)$$

bu yerda ρ – modda zichligi, kg / m^3 ;
 m – modda massasi, kg ;
 V – hajm, m^3 .

Solishtirma hajm va modda zichligi o‘rtasidagi nisbat

$$\rho \cdot v = 1. \quad (1.11)$$

Solishtirma og‘irlik quyidagi formula bo‘yicha hisoblab topiladi,
 N/m^3

$$\gamma = g \cdot \rho \quad (1.12)$$

XIX asrda eksperimentlar yordamida ideal gazga yaqin bo‘lgan gazlar uchun termik parametrlar orasidagi quyidagi nisbatlar belgilab olindi:

– izobarik jarayon uchun $p = \text{const}$, $v / T = \text{const}$ – Gey-Lyussak qonuni;

– izoxorik jarayon uchun $v = \text{const}$, $p / T = \text{const}$ – Sharl qonuni;

– izotermik jarayon uchun $T = \text{const}$, $p / \rho = \text{const}$ yoki $\rho \cdot v = \text{const}$ – p · v = 1 Boyl – Mariott qonuni nisbatini hisobga olgan holda.

1834-yilda fransuz olimi Klapeyron ana shu qonunlarni birlashtirib, barcha uchta termodinamik (termik) parametr p , v va T larni o‘zaro bog‘lagan xarakteristik tenglamaga ega bo‘ldi. Ushbu tenglama ideal gaz holat tenglamasi deb nomlanadi.

1 kg gaz uchun ideal gaz holat tenglamasi quyidagi ko‘rinishga ega:

$$p \cdot v = R \cdot T, \quad (1.13)$$

bu yerda p – mutlaq bosim, Pa ;

v – solishtirma hajm, m^3 / kg ;

T – mutlaq harorat, $^{\circ}\text{K}$;

R – universal gaz doimiysi yoki gaz doimiysi, $\text{J} / (\text{kg} \cdot ^{\circ}\text{K})$.

Ushbu tenglamaning chap va o‘ng tarafini gaz massasiga ko‘paytirib, m massali gaz uchun holat tenglamasini olamiz:

$$p \cdot m \cdot v = m \cdot R \cdot T \text{ yoki } p \cdot V = m \cdot R \cdot T, \quad (1.14)$$

bu yerda $V = m \cdot v$ – gaz hajmi, m^3 .

SI tizimida modda miqdori mol va kilomollarda o‘lchanadi:

$$1 \text{ kmol} = 10^3 \text{ mol}.$$

Gaz (modda) kmoli kilogrammlardagi massasi molyar (nisbiy molekulyar) massaga teng bo'lgan gaz (modda) miqdoriga teng.

Molyar gaz massasi μ – bu gazning 1 kmol miqdorida olingan kilogrammlardagi massasi (moddaning).

Masalan, kislorodda (O_2) 1 kmol 32 kg ga va molyar massa $\mu_{O_2} = 32$ kg/kmolga teng.

Kilomollar soni orqali ifodalangan gaz massasi m , quyidagiga teng

$$m = n \cdot \mu, \quad (1.15)$$

bu yerda m – gaz massasi, kg;

μ – molyar massa, kg / kmol;

n – kilomollar soni, kmol.

Yuqorida berilgan qonunlardan tashqari, gazlar Avogadro qonuniga ham bo'ysunib, unda belgilanishicha, barcha gazlar bir xil harorat va bosimda teng hajmdagi bir xil miqdordagi molekullarga ega bo'ladilar.

Bundan gaz zichligi uning molyar massasiga to'g'ri proporsional ekanligi kelib chiqadi:

$$\frac{\rho_1}{\rho_2} = \frac{\mu_1}{\mu_2} \quad (1.16)$$

yoki, $\rho \cdot v = 1$ nisbatini hisobga olib, quyidagini olamiz:

$$\frac{v_1}{v_2} = \frac{\mu_1}{\mu_2} \quad (1.17)$$

bundan quyidagi nisbat kelib chiqadi:

$$\mu_1 \cdot v_1 = \mu_2 \cdot v_2 = \mu \cdot v = V_\mu = \text{const}, \quad (1.18)$$

bu yerda V_μ – kilomol hajmi, m^3 / kmol .

Shunday qilib, barcha ideal gazlar uchun bir xil harorat T va bosimda p bir kilomol hajmi ham bir xil bo'ladi.

Normal sharoitlarda ($p_0 = 760$ mm. sim. ust. = 101,3 kPa va $T_0 = 273,15$ °K) har qanday 1 kmol gazning hajmi $V_{\mu_0} = 22,4146$ m^3 / kmol ga teng.

D. I. Mendeleyev 1874-yilda μ , kg ideal gaz holati uchun (1 kilomol uchun) universal tenglamasini oldi:

$$p \cdot \mu \cdot v = \mu \cdot R \cdot T \text{ yoki } p \cdot V_{\mu} = R_{\mu} \cdot T, \quad (1.19)$$

bu yerda $V_{\mu} = \mu \cdot v$ - 1 kmol hajmi, m^3 / kmol ;

$R_{\mu} = \mu \cdot R = 8314,3 \text{ J} / (\text{kmol} \cdot ^\circ\text{K})$ – universal yoki molyar gaz doimiysi.

1.2-jadvalda turli gazlarning molyar massalari keltirilgan.

1.2-jadval

Gazlarning molyar massalari

Gaz	μ , kg / kmol
Vodorod H_2	2,016
Azot N_2	28,03
Kislorod O_2	32,00
Havo 21% O_2 +79% N_2	28,96
Metan CH_4	16,03
Uglerod oksidi CO	28,01
Karbonat angidrid CO_2	44,01
Geliy He	4,003
Argon Ag	39,94

1.1-masala. 1,2 m^3 hajmli idishda 2,5 kg uglerod oksidi (CO) bor. Uglerod oksidining solishtirma hajmi va zichligi aniqlansin.

Yechim: Solishtirma hajmi

$$v = \frac{V}{m} = \frac{1,2 \text{ m}^3}{4,8 \text{ kg}}$$

Zichligi

$$\rho = \frac{1}{v} = \frac{1}{0,48} \frac{\text{kg}}{\text{m}^3}$$

Javob: $v = 0,48 \text{ m}^3 / \text{kg}$; $\rho = 2,08 \text{ kg} / \text{m}^3$.

1.2-masala. Agar manometr $p_m = 0,18 \text{ MPa}$ ni ko'rsatayotgan bo'lsa, qozondagi bug'ning mutlaq bosimi topilsin. Simobli barometr ko'rsatkichlari bo'yicha atmosfera bosimi $t = 30 \text{ }^\circ\text{C}$ haroratda $P_{\text{bar}} = 740 \text{ mm}$ sim. ust. ni tashkil qiladi.

Yechim: Barometr ko'rsatkichlari simobning $t = 30\text{ }^{\circ}\text{C}$ haroratida olingan. Bu ko'rsatmani quyidagi formula bo'yicha $0\text{ }^{\circ}\text{C}$ ga keltirish shart:

$$P_{\text{bar}0} = P_{\text{bar}} \cdot (1 - 0,000172 \cdot t) = 740 \cdot (1 - 0,000172 \cdot 30) = 736,1816 \text{ mm sim.ust.} = 736,1816 \cdot 133,3 = 98133,01 \text{ Pa.}$$

Ozondagi bug'ning mutlaq bosimi:

$$p = p_{\text{bar}} + p_{\text{m}} = 98133,01 + 0,18 \cdot 10^6 = 278133,01 \text{ Pa} = 0,278 \text{ MPa}$$

Javob: $p = 0,228 \text{ MPa}$.

1.3-masala. $0,75 \text{ m}^3$ havo $140\text{ }^{\circ}\text{C}$ haroratda idish ichida joylashgan. Idishga ulangan vakuummetr 695 mm suv. ust. siyraklashini ko'rsatadi. Barometrik bosim 745 mm sim. ust. bo'lganida idishdagi gaz massasi aniqlansin.

Yechim: Gazning mutlaq bosimi

$$p = p_{\text{bar}} - p_{\text{vak}} = 745 \cdot 133,3 - 695 \cdot 9,81 = 92490,55 \text{ Pa.}$$

Havoning mutlaq harorati

$$T = t + 273,15 = 140 + 273,15 = 413,15 \text{ }^{\circ}\text{K.}$$

$$R = \frac{R_{\mu}}{\mu} = \frac{8314}{28,96} = 287,09 \frac{\text{J}}{\text{kg} \cdot ^{\circ}\text{K}}$$

Gaz doimiysi

$p \cdot V = m \cdot R \cdot T$ ko'rinishida yozib olingan ideal gaz holatining tenglamasidan gaz massasini ifodalaymiz:

$$m = \frac{p \cdot V}{R \cdot T} = \frac{92490,55 \cdot 0,75}{287,09 \cdot 413,15} = 0,585 \text{ kg.}$$

Javob: $m = 0,585 \text{ kg}$.

1.4-masala. Agar normal fizik sharoitlarda kislorod 5 m^3 hajmni egallasa, u $170\text{ }^{\circ}\text{C}$ harorat va $0,5 \text{ MPa}$ bosimda qanday hajm egallaydi?

Yechim: Normal fizik sharoitlar deganda $p = 760 \text{ mm}$ sim. ust. va $t = 0\text{ }^{\circ}\text{C}$ bo'lgandagi gaz holati tushuniladi. Normal fizik sharoitlar va mazkur masala fizik sharoitlari uchun ideal gaz holatining tenglamasi:

$$m = \frac{p_1 V_1}{R T_1} = \frac{p_{n.sh} V_{n.sh}}{R T_{n.sh}} \Rightarrow V_1 = \frac{T_1 p_{n.sh} V_{n.sh}}{p_1 T_{n.sh}}$$

Mutlaq bosim:

$$p_{n.sh} = 760 \cdot 133,3 = 101308 \text{ Pa} = 1,013 \cdot 10^5 \text{ Pa};$$

$$p_1 = 0,5 \text{ MPa} = 0,5 \cdot 10^6 \text{ Pa}.$$

Mutlaq harorat:

$$T_{n.sh} = 273,15 \text{ }^\circ\text{K};$$

$$T_1 = 170 + 273,15 = 443,15 \text{ }^\circ\text{K}$$

Berilgan sharoitlarda hajmni hisoblab topish uchun $p_{n.sh}$, p_1 , $T_{n.sh}$, T_1 qiymatlarini formulaga qo'yib ko'ramiz:

$$V_1 = \frac{443,15 \cdot 1,013 \cdot 10^5 \cdot 5}{0,5 \cdot 10^6 \cdot 273,15} = 1,643 \text{ m}^3$$

Javob: $V = 1,643 \text{ m}^3$.

1.5-masala. Azot harorati $70 \text{ }^\circ\text{C}$ ga teng bo'lganida 5 kg azot 2 m^3 hajmni egallaydigan bosim aniqlansin?

Javob: $0,25 \text{ MPa}$.

1.6-masala. $0,5 \text{ m}^3$ sig'imli ballonda $30 \text{ }^\circ\text{C}$ harorat va $0,5 \text{ MPa}$ ortiqcha bosimda azot bor. Agar ortiqcha bosim $0,2 \text{ MPa}$ gacha, harorat esa $-20 \text{ }^\circ\text{C}$ gacha pasaygan bo'lsa, ballondan chiqarib yuborilgan azot massasi aniqlansin. Barometrik bosim 750 mm simob ust. ga teng.

Javob: $1,61 \text{ kg}$.

1.7-masala. Havo hajmi $0,6 \text{ MPa}$ bosim va $100 \text{ }^\circ\text{C}$ haroratda 3 m^3 ni tashkil qiladi. Normal fizik sharoitlarda havo qanday hajm egallaydi?

Javob: 13 m^3 .

1.8-masala. Agar vodorod $50 \text{ }^\circ\text{C}$ haroratda idish ichida joylashib, barometrik bosim 760 mm sim. ust. ga teng bo'lganida, uning ortiqcha bosimi 50 mm suv ust. ga teng bo'lsa, vodorod zichligi aniqlansin.

Javob: $0,079 \text{ kg / m}^3$.

1.9-masala. Qo'zg'aluvchan porshenli silindrda $0,1 \text{ MPa}$ bosim ostidagi $0,2 \text{ m}^3$ bor. Bosim $0,2 \text{ MPa}$ gacha oshganida havo harorati o'zgarishsizligi uchun hajm qay darajada o'zgarishi kerak?

Javob: Hajmi 2 marotaba kamayadi.

1.10-masala. $0,6 \text{ m}$ diametrlilik silindr ichida $0,25 \text{ MPa}$ bosim va $t_1 = 35 \text{ }^\circ\text{C}$ haroratda $0,4 \text{ m}^3$ havo mavjud. Ishqalanishsiz harakatlanayotgan porshen $0,4 \text{ m}$ ga ko'tarilishi uchun havo doimiy bosimda qanday haroratga (t_2) qadar isitilishi kerak?

Javob: $t_2 = 122 \text{ }^\circ\text{C}$.

1.2. Gaz aralashmalari. Gazlar va gaz aralashmalarining issiqlik sig'implari

Issiqlik sig'imi tushunchasini fanga birinchi bo'lib ingliz fizigi Blek 1760-yilda quyidagi ko'rinishda kiritgan: «Moddaning issiqlik sig'imi jismni 1 °C (1 °K) ga isitish yoki sovutish uchun zarur bo'lgan issiqlik miqdoriga teng»

$$C = \frac{\delta Q}{dT} = \frac{\delta Q}{dt}, \quad (1,20)$$

bu yerda C – moddaning issiqlik sig'imi, $J / ^\circ K = J / ^\circ C$;

δQ – issiqlikning elementar miqdori, J ;

dT – jism haroratining o'zgarishi, $^\circ K$;

dt – jism haroratining o'zgarishi, $^\circ C$.

Zamonaviy izoh bilan aytganda, issiqlik sig'imi harorat o'zgarishi va ana shu o'zgarishni keltirib chiqargan issiqlik miqdori o'rtasidagi mutanosiblik (*proporsionallilik*) koeffitsiyentidir

$$\delta Q = C \cdot dT = C \cdot dt. \quad (1,21)$$

Eslatib o'tamiz, haroratlarning termodinamik shkalasida harorat o'zgarishi va haroratlarning xalqaro amaliy shkalasi bo'yicha o'zaro teng: $dT = dt$.

Issiqlik sig'imi – haroratga bog'liq holda tajribalar yordamida aniqlanadigan moddaning fizik tavsifi.

Termodinamik jarayonda ishchi jismga berilgan issiqlik miqdori shu jismning solishtirma issiqlik sig'imi orqali aniqlanadi:

c – solishtirma massa issiqlik sig'imi, $J / (kg \cdot ^\circ K)$

$$c = \frac{C}{m}, \quad (1,22)$$

bu yerda C – moddaning issiqlik sig'imi, $J / ^\circ K$;

m – modda massasi, kg ;

c' – solishtirma hajmiy issiqlik sig'imi, $J / (m^3 \cdot ^\circ K)$

$$c' = \frac{C}{V}, \quad (1,23)$$

bu yerda C – moddaning issiqlik sig'imi, $J / ^\circ K$;

V – moddaning hajmi, m^3 ;

c_μ – solishtirma mollardagi yoki molyar issiqlik sig'imi, $J / (kmol \cdot ^\circ K)$

$$c_{\mu} = \frac{C}{n}, \quad (1.24)$$

bu yerda C – issiqlik sig‘imi, $J / ^{\circ}K$;

n – modda miqdori, kmol.

Izoh. Molyar issiqlik sig‘imini belgilash uchun shuningdek $\mu c \equiv c_{\mu}$ belgisidan ham foydalanadilar.

Modda massasi quyidagiga teng ekanligini hisobga olib,

$$m = \rho \cdot V = \mu \cdot n \quad (1.25)$$

Solishtirma issiqlik sig‘imlari uchun quyidagi nisbatlarga ega bo‘lamiz:

$$c = \frac{c'}{\rho} = \frac{c_{\mu}}{\mu}, \quad (1.26)$$

bu yerda c – solishtirma massa issiqlik sig‘imi, $J / (kg \cdot ^{\circ}K)$;

c' – solishtirma hajmiy issiqlik sig‘imi, $J / (m^3 \cdot ^{\circ}K)$;

c_{μ} – molyar issiqlik sig‘imi, $J / (kmol \cdot ^{\circ}K)$;

ρ – moddaning zichligi, kg / m^3 ;

μ – molyar massa, $kg / kmol$;

n – moddaning miqdori, kmol.

Issiqlik sig‘imi termodinamik jarayonning kechish xarakteriga bog‘liq bo‘lib, umumiy holda, $-\infty$ dan $+\infty$ gacha oraliqda o‘zgarishi mumkin.

Termodinamik hisob – kitoblarda doimiy hajm c_v va doimiy bosim c_p dagi solishtirma issiqlik sig‘imlari eng ko‘p qo‘llanadilar.

Ideal gazning issiqlik sig‘imi harorat va bosimga bog‘liq emas va uni gazlarning molekulyar-kinetik nazariyasini qo‘llagan holda hisoblab topish mumkin.

Molekulyar – kinetik nazariyasiga muvofiq ideal gazlarning solishtirma molyar, massa va hajmiy izoxorik izobarik issiqlik sig‘imlari doimiy bo‘lib, quyidagi formulalarga binoan hisoblab topiladi:

$$\begin{aligned} \mu c_v &= \frac{R_{\mu}}{2} \cdot i, \frac{J}{kmol \cdot ^{\circ}K}; \\ \mu c_p &= \frac{R_{\mu}}{2} \cdot (i + 2), \frac{J}{kmol \cdot ^{\circ}K}; \\ c_v &= \frac{\mu c_v}{\mu} = \frac{R}{2} \cdot i, \frac{J}{kmol \cdot ^{\circ}K}; \end{aligned}$$

$$\begin{aligned}
c_p &= \frac{\mu c_p}{\mu} = (i + 2), \frac{J}{\text{kmol} \cdot ^\circ K}; \\
c'_v &= \frac{\mu c_v}{\nu_\mu} = \frac{J}{m^3 \cdot ^\circ K}; \\
c'_p &= \frac{\mu c_p}{\nu_\mu} = \frac{J}{m^3 \cdot ^\circ K}; \\
c'_{v_{n.sh}} &= \frac{\mu c_v}{22,4} = \frac{J}{Nm^3 \cdot ^\circ K}; \\
c'_{v_{n.sh}} &= \frac{\mu c_p}{22,4} = \frac{J}{Nm^3 \cdot ^\circ K}.
\end{aligned}
\tag{1,27}$$

bu yerda i – ushbu gaz molekulasini erkinlik darajalari soni;

ν_μ – kmol gaz hajmi, m / kmol;

R – gaz doimiysi, J / (kg · °K);

R_μ – universal gaz doimiysi, $R_\mu = 8314$ J / (kmol · °K).

Bir atomli gaz uchun $i = 3$, ikki atomli gazlar uchun $i = 5$, uch va ko'p atomli gazlar uchun esa $i = 6$.

Ideal gazlarning izobarik va izoxorik issiqlik sig'implari o'zaro Mayer tenglamasi yordamida bog'langan:

$$c_p - c_v = R$$

yoki:

$$\mu c_p - \mu c_v = R_\mu. \tag{1,28}$$

Puasson koeffitsiyenti yoki adiabat ko'rsatkichi quyidagiga teng:

$$k = \frac{c_p}{c_v} = \frac{\mu c_p}{\mu c_v} \tag{1,29}$$

Real moddalarning issiqlik sig'imi

Real gazlar, suyuqliklar va qattiq jismlarning issiqlik sig'imi haroratga bog'liq holda eksperiment (tajriba) orqali topilib, spravochniklarda keltiradilar. 1-2 jarayonlardagi o'rtacha solishtirma issiqlik sig'imi quyidagiga teng:

$$\bar{c} = \frac{q_{12}}{T_2 - T_1} = \frac{q_{12}}{t_2 - t_1} \quad (1.30)$$

bu yerda \bar{c} - o'rtacha massa issiqlik sig'imi, J / (kg · °K).

Spravochniklarda izobarik issiqlik sig'imlari qiymatlari keltiriladi. Bunda, agar haqiqiy issiqlik sig'imi $c(t)$ ma'lum bo'lsa, u holda o'rtacha issiqlik sig'imini quyidagi formulalar bo'yicha hisoblab topish mumkin:

$$c_p = \frac{q_{12}}{t_2 - t_1} = \frac{1}{t_2 - t_1} \int_{t_1}^{t_2} c_p(t) dt \quad (1.31)$$

yoki:

$$\bar{c}_p = c_p \Big|_{t_1}^{t_2} = \frac{c_p \Big|_{t_2}^{t_2} t_2 - c_p \Big|_{t_1}^{t_1} t_1}{t_2 - t_1}, \quad (1.32)$$

$c_p \Big|_0^t = \int_0^t c_p(t) dt$ – bu yerda $-0 \div t$ haroratlar intervalidagi o'rtacha issiqlik sig'imi.

Ideal gaz aralashmalari

Ideal gaz aralashmalari ideal gaz holati tenglamasiga bo'ysunadilar:

$$P_{\text{aral}} \cdot v_{\text{aral}} = R_{\text{aral}} \cdot T_{\text{aral}} - 1 \text{ kg gaz aralashmasi uchun,} \quad (1.33)$$

bu yerda R_{aral} – aralashmaning gaz doimiysi.

$$R_{\text{aral}} = \frac{R_{\mu}}{\mu_{\text{aral}}} \quad (1.33')$$

Ideal gazlar aralashmasi tarkibi massa yoki hajmiy ulushlar bilan berilishi ham mumkin. Aralashmaning massa ulushi quyidagiga teng:

$$g_i = \frac{m_i}{m_{\text{aral}}} \quad (1.34)$$

bu yerda m_i – gazlar aralashmasi i – nchi komponenti massasi, kg;

m_{aral} – aralashma massasi, kg.

Aralashmaning hajmiy ulushi quyidagiga teng:

$$r_i = \frac{V_i}{V_{\text{aral}}} = \frac{p_i}{p_{\text{aral}}} \quad (1.35)$$

bu yerda V_i, p_i – gazlar aralashmasi i – nchi komponentining parsial hajmi va parsial bosimi;

$V_{\text{aral}}, p_{\text{aral}}$ – gazlar aralashmasining hajmi va bosimi.

Gazlar aralashmasining massa va hajmiy ulushlari summasi birga teng:

$$\sum_{i=1}^n g_i = 1, \quad \sum_{i=1}^n r_i = 1. \quad (1.36)$$

Gaz aralashmasining massa va hajmiy ulushlari orasida quyidagi nisbatlar mavjud:

$$g_i = r_i \frac{\mu_i}{\mu_{aral}} = r_i \frac{R_{aral}}{R_i};$$

$$r_i = g_i \frac{\mu_{aral}}{\mu_i} = g_i \frac{R_i}{R_{aral}} \quad (1.37)$$

bu yerda μ_{aral} – kilomol aralashmaning massasi, kg / kmol;

R_{aral} – aralashmaning gaz doimiysi, J / (kg · °K).

Aralashmaning molyar massasi va gaz doimiysi ideal gazlar aralashmasi n quyidagi formulalar bo'yicha hisoblab topiladi:

$$\mu_{aral} = \sum_{i=1}^n r_i \cdot \mu_i;$$

$$R_{aral} = \sum_{i=1}^n g_i \cdot R_i \quad (1.38)$$

Termodinamik hisob-kitoblarda quyidagilar hisobga olinishi shart:

$$R_{aral} = \frac{R\mu}{\mu_{aral}} = \frac{8314}{\mu_{aral}} \quad (1.38')$$

Ideal gazlar aralashmasi n ning massa, molyar va hajmiy issiqlik sig'imi quyidagi formulalar bo'yicha hisoblab topiladi:

$$c_{aral} = \sum_{i=1}^n g_i \cdot c_i;$$

$$\mu c_{aral} = \sum_{i=1}^n r_i \cdot \mu c_i$$

$$c'_{aral} = \sum_{i=1}^n r_i \cdot c'_i \quad (1.39)$$

Puasson koeffitsiyenti (adiabata ko'rsatkichi) ideal gazlar aralashmasi uchun quyidagiga teng:

$$k_{aral} = \frac{\mu c_{p,aral}}{\mu c_{v,aral}} = \frac{c_{p,aral}}{c_{v,aral}} \quad (1.40)$$

1.11-masala. Gaz aralashmasi tarkibiga quyidagilar kiradi: 2,5 kg azot, 6 kg kislorod va 1,5 kg ikki oksidli uglerod (dвуokis). Barcha gazlar ideal deb hisoblanib, aralashma 4 bar bosim va 189 °C haroratda qanday hajmni egallashi aniqlansin.

Yechim: Aralashmaning massasi:

$$m_{\text{aral}} = m_{\text{N}_2} + m_{\text{O}_2} + m_{\text{CO}_2} = 2,5 + 6 + 1,5 = 10 \text{ kg.}$$

Aralashmaning massaviy ulushlari:

$$g_{\text{O}_2} = 0,6; g_{\text{N}_2} = 0,25; g_{\text{CO}_2} = 0,15.$$

Aralashmaning gaz doimiysi:

$$R_{\text{aral}} = \sum_{i=1}^m g_i R_i = 0,6 \cdot \frac{8314}{32} + 0,25 \cdot \frac{8314}{28} + 0,15 \cdot \frac{8314}{44} = 258,463 \frac{\text{J}}{\text{kg} \cdot ^\circ\text{K}}$$

Aralashmaning hajmi:

$$V_{\text{aral}} = \frac{m_{\text{aral}} \cdot R_{\text{aral}} \cdot T_{\text{aral}}}{p_{\text{aral}}} = \frac{10 \cdot 258,463 \cdot (189 + 273,15)}{4 \cdot 10^5} = 2,986 \text{ m}^3$$

Javob: $V_{\text{aral}} = 2,986 \text{ m}^3$.

1.12-masala. Havo atmosferasidagi azotning solishtirma izobarali va izoxorali issiqlik sig'implari aniqlansin.

Yechim: Havo atmosferasidagi azot – ikki atomli gaz. Erkinlik darajalari soni $i = 5$, atmosfera azotining molyar massasi $\mu = 28,16 \text{ kg / kmol}$.

Havo atmosferasi tarkibidagi azotning solishtirma molyar izoxorali issiqlik sig'imi:

$$\mu c_v = R_\mu \frac{i}{2} = 8314 \frac{5}{2} = 20780 \frac{\text{J}}{\text{kmol} \cdot ^\circ\text{K}}$$

Mayer tenglamasiga ko'ra atmosfera havo tarkibidagi azotning solishtirma molyar izobarali issiqlik sig'imini aniqlash mumkin:

$$\mu c_p = \mu c_v + R_\mu = 29099 \frac{\text{J}}{\text{kmol} \cdot ^\circ\text{K}}$$

Solishtirma issiqlik sig'implari orasidagi nisbatlardan foydalanib quyidagilarni olamiz:

– massa issiqlik sig‘imlari:

$$c_p = \frac{\mu c_p}{\mu} = \frac{29099}{28,16} = 1033,345 \frac{J}{kg \cdot ^\circ K};$$

$$c_v = \frac{\mu c_v}{\mu} = \frac{20780}{28,16} = 737,926 \frac{J}{kg \cdot ^\circ K}.$$

– ($V_{\mu n.sh} = 22,4 \text{ Nm}^3/\text{kmol}$) bo‘lganida normal fizik sharoitlardagi hajmiy issiqlik sig‘imlari:

$$c'_{v n.sh} = \frac{\mu c_v}{V_{\mu n.sh}} = \frac{20780}{22,4} = 927,618 \frac{J}{\text{Nm}^3 \cdot ^\circ K};$$

$$c'_{p n.sh} = \frac{\mu c_p}{V_{\mu n.sh}} = \frac{29099}{22,4} = 1299,06 \frac{J}{\text{Nm}^3 \cdot ^\circ K}.$$

1.13-masala. O‘rtacha issiqlik sig‘imlari jadvallari bo‘yicha [3] harorat 200°C dan 1200°C gacha o‘zgarishida normal sharoitlardagi gazlar aralashmasi uchun o‘rtacha hajmiy izobarik issiqlik sig‘imi aniqlansin. Aralashmaning hajmiy tarkibi: 13,5 % karbonat anhidrid, 7,5 % kislorod, 79 % azot.

Yechim: O‘rtacha issiqlik sig‘imlari jadvallari bo‘yicha molyar issiqlik sig‘imlari haroratning 0°C dan $t^\circ\text{C}$ gacha interval oralig‘ida quyidagiga teng bo‘ladi:

– karbonat anhidrid:

$$\mu c_{pm} |_0^{200} = 40,06 \frac{kJ}{\text{kmol} \cdot ^\circ K};$$

$$\mu c_{pm} |_0^{1200} = 50,74 \frac{kJ}{\text{kmol} \cdot ^\circ K}.$$

– kislorod:

$$\mu c_{pm} |_0^{200} = 29,93 \frac{kJ}{\text{kmol} \cdot ^\circ K};$$

$$\mu c_{pm} |_0^{1200} = 33,63 \frac{kJ}{\text{kmol} \cdot ^\circ K};$$

– azot:

$$\mu c_{pm} |_0^{200} = 29,29 \frac{kJ}{\text{kmol} \cdot ^\circ K};$$

$$\mu c_{pm} |_0^{1200} = 31,82 \frac{kJ}{\text{kmol} \cdot ^\circ K};$$

Aralashma komponentlari haroratning $t_1 \div t_2$ intervalidagi o'rtacha molyar issiqlik sig'irlarini quyidagi formula bo'yicha hisoblab topamiz:

$$\mu C_{pm} \Big|_{t_1}^{t_2} = \frac{\mu C_{pm} \Big|_0^{t_2} \cdot t_2 - \mu C_{pm} \Big|_0^{t_1} \cdot t_1}{t_2 - t_1}$$

Aralashma komponentlari $t_1 \div t_2$ harorat intervalidagi o'rtacha molyar issiqlik sig'irlari:

– karbonat anhidrid:

$$\mu C_{pm} \Big|_{200}^{1200} = \frac{50,74 \cdot 1200 - 29,93 \cdot 200}{1200 - 200} = 52,876 \frac{kJ}{kmol \cdot ^\circ K};$$

– kislorod:

$$\mu C_{pm} \Big|_{200}^{1200} = \frac{33,63 \cdot 1200 - 29,93 \cdot 200}{1200 - 200} = 34,37 \frac{kJ}{kmol \cdot ^\circ K};$$

– azot:

$$\mu C_{pm} \Big|_{200}^{1200} = \frac{31,82 \cdot 1200 - 29,29 \cdot 200}{1200 - 200} = 32,326 \frac{kJ}{kmol \cdot ^\circ K}.$$

Normal sharoitlarda gaz aralashmasi komponentlari o'rtacha hajmiy izobarik issiqlik sig'irlari:

– karbonat anhidrid:

$$c'_{pm,n.sh} = \frac{\mu C_{pm}}{V_{\mu n.sh}}$$

$$c'_{pm,n.sh} = \frac{52,876}{22,4} = 2,36 \frac{J}{Nm^3 \cdot ^\circ K};$$

– kislorod:

$$c'_{pm,n.sh} = \frac{34,37}{22,4} = 1,534 \frac{J}{Nm^3 \cdot ^\circ K},$$

– azot:

$$c'_{pm,n.sh} = \frac{32,326}{22,4} = 1,44 \frac{J}{Nm^3 \cdot ^\circ K}$$

Gaz aralashmasi komponentlari o'rtacha molyar issiqlik sig'implari:

$$c'_{pmaral} = \sum_{i=1}^m r_i \cdot c'_{pm_i} = 0,135 \cdot 2,36 + 0,075 \cdot 1,534 + 0,79 \cdot 1,44 = 1,57 \frac{J}{Nm^3 \cdot ^\circ K}$$

Javob: $c'_{pm\ n.sh} = 1,57 J / Nm^3 \cdot ^\circ K$

1.14-masala. $\mu = 42 \text{ kg} / \text{kmol}$ bo'lgan gaz aralashmasining haqiqiy molyar izobarik issiqlik sig'imi quyidagi tenglama bilan ifodalanadi:

$$\mu c_p = 40 + 0,003 \cdot t + 0,000001 t^2, \frac{J}{Nm^3 \cdot ^\circ K}$$

Izoxorik jarayonda aralashma $90 \text{ }^\circ\text{C}$ dan $900 \text{ }^\circ\text{C}$ gacha qiziydi. 8 kg aralashmani qizdirishga ketadigan issiqlik sarfi aniqlansin.

Yechim: Izoxorik jarayon issiqligi quyidagi formula bo'yicha hisoblab topiladi:

$$Q_v = m \cdot q_v,$$

bu yerda $q_v = \int_{t_1}^{t_2} c_v \cdot dt,$

$$c_v = \frac{\mu c_p}{\mu} = \frac{\mu c_p - R_u}{\mu} = \frac{40 + 0,003 \cdot t + 0,000001 \cdot t^2 - 8,314}{42} = \frac{31,686 + 0,003 \cdot t + 0,000001 \cdot t^2}{42}$$

$$q_v = \int_{90}^{900} \frac{31,686 + 0,003 \cdot t + 0,000001 \cdot t^2}{42} \cdot dt$$

$$= \frac{1}{42} \left| \frac{31,686 \cdot t}{1} + 0,003 \frac{t^2}{2} + 0,000001 \cdot \frac{t^3}{3} \right|_{90}^{900} = 645,5 \frac{kJ}{ka}$$

$$Q_v = 8 \cdot 645,5 = 5164 \text{ kJ.}$$

Javob: $Q_v = 5164 \text{ kJ.}$

1.15-masala. Vodorod va metan aralashmasining gaz doimiysi $2520 \text{ J} / (\text{kg } ^\circ\text{K})$ ga teng. Aralashmaning massasi va hajmi bo'yicha tarkibi aniqlansin.

Javob: $r_{H_2} = 0,907;$ $r_{CH_4} = 0,093;$
 $g_{H_2} = 0,55;$ $g_{CH_4} = 0,45.$

1.16-masala. Aralashma azot va uglerod ikki oksididan iborat. 27 °C haroratda va manometrik bosim 2 bar bo'lganida 4 kg aralashma 0,96 m³ hajmi egallaydi. Gazlarni ideal deb hisoblab, agar simobli barometr 27 °C haroratda atmosfera havosining 730 mm sim. ust. bosimini ko'rsatayotgan bo'lsa, aralashma uchun gaz doimiysi, molyar massasi, zichlik va solishtirma hajm, shuningdek, aralashma komponentlari parsial bosimlari aniqlansin.

Javob: $R = 237 \text{ J / kg } \cdot \text{ }^\circ\text{K}$; $\mu = 35 \text{ kg / kmol}$; $v = 0,24 \text{ m}^3 / \text{kg}$;
 $\rho = 4,16 \text{ kg / m}^3$; $p_{\text{N}_2} = 1,67 \text{ bar}$; $p_{\text{CO}_2} = 1,33 \text{ bar}$.

1.17-masala. Ideal gazlar aralashmasi massasi bo'yicha 20 % ga SO₂, 15 % SO, 10 % O₂, 55 % N₂ lardan tashkil topgan. Agar aralashmaning bosimi 0,5 MPa bo'lsa, aralashmaning hajmiy tarkibi, aralashma tarkibiga kirgan gazlarning parsial bosimlari, molyar va massa izoxorali issiqlik sig'irlari aniqlansin.

Javob: $r_{\text{CO}_2} = 0,139$; $p_{\text{CO}_2} = 0,0695 \text{ MPa}$;
 $r_{\text{CO}} = 0,164$; $p_{\text{CO}} = 0,082 \text{ MPa}$;
 $r_{\text{O}_2} = 0,096$; $r_{\text{O}_2} = 0,048 \text{ MPa}$;
 $r_{\text{N}_2} = 0,601$; $p_{\text{N}_2} = 0,3005 \text{ MPa}$;
 $c_{v \text{ aral}} = 0,7216 \text{ kJ / kg } \cdot \text{ }^\circ\text{K}$; $\mu_{c_{v \text{ aral}}} = 23,87 \text{ kJ / kmol } \cdot \text{ }^\circ\text{K}$.

1.18-masala. Ideal gazlar aralashmasi 6 kg SO₂, 4 kg O₂ va 10 kg N₂ dan tashkil topgan. Aralashmaning gaz doimiysi, aralashmaning molyar massasi va aralashmaning massa izobarali issiqlik sig'imi aniqlansin.

Javob: $R_{\text{aral}} = 256,35 \text{ J / (kg } \cdot \text{ }^\circ\text{K)}$; $\mu_{\text{aral}} = 32,43 \text{ kg / kmol}$;
 $c_{p \text{ aral}} = 0,5906 \text{ kJ / (kg } \cdot \text{ }^\circ\text{K)}$;

1.19-masala. Agar aralashmaning hajmiy tarkibi: 10 % vodorod, 10 % uglerod oksidi, 40 % karbonat anhidrid, 40 % azot sifatida berilgan bo'lsa, ideal gazlar aralashmasining massa izoxora va izobara issiqlik sig'irlari aniqlansin.

Javob: $c_v = 0,706 \text{ kJ / (kg } \cdot \text{ }^\circ\text{K)}$; $c_p = 0,976 \text{ kJ / (kg } \cdot \text{ }^\circ\text{K)}$.

1.20-masala. Agar quyidagicha bo'lsa, havoning o'rtacha haroratlari 200 °C÷800 °C intervalida havoning doimiy bosimidagi massa issiqlik sig'imi hisoblab aniqlansin:

a) o'rtacha massa izobarali issiqlik sig'irlari berilgan:

$$c_{pm} \Big|_{200}^{800} = 1,0115 \frac{\text{kJ}}{\text{kg} \cdot \text{ }^\circ\text{K}}$$

$$c_{pm} \Big|_{200}^{800} = 1,0710 \frac{\text{kJ}}{\text{kg} \cdot \text{ }^\circ\text{K}}$$

b) havoning o'rtacha molyar izobarali issiqlik sig'imi berilgan bo'lib, u quyidagi formula bilan aniqlanadi:

$$\mu c_{pm} = 28,827 + 0,0027080 \cdot t.$$

Javob:

$$a) c_{pm} \mid \frac{800}{200} = 1,09 \frac{kJ}{kg \cdot ^\circ K};$$

$$b) c_{pm} \mid \frac{800}{200} = 1,088 \frac{kJ}{kg \cdot ^\circ K}.$$

1.3. Ideal gazlar holatining o'zgarishiga doir termodinamik jarayonlar

Gazlarning termodinamik jarayonlari politrop va izotrop jarayonlarga (izojarayonlar) bo'linadilar. Politrop jarayonlarda bir vaqtning o'zida barcha holat parametrlar o'zgaradi. Izotrop jarayonlarda parametrlardan biri o'zgarib qoladi.

Ideal gaz holatining o'zgarishi bilan bog'liq asosiy izojarayonlar (izobarali, izoxorali, izotermik, adiabatoli) politrop jarayonning xususiy holati bo'lib, uning tenglamasi quyidagi ko'rinishga ega:

$$p \cdot v^n = \text{const}, \quad (1.41)$$

bu yerda n - politropa ko'rsatkichi.

Politropa ko'rsatkichi quyidagi formula bo'yicha hisoblab topiladi:

$$n = \frac{c_p - c_v}{c - c_v} \quad (1.42)$$

bu yerda c – politrop jarayonning massasi bo'yicha solishtirma issiqlik sig'imi, $J / (kg \cdot ^\circ K)$;

c_p – doimiy bosimdagi massasi bo'yicha solishtirma issiqlik sig'imi (izobarik issiqlik sig'imi), $J / (kg \cdot ^\circ K)$;

c_v – doimiy hajmdagi solishtirma yalpi issiqlik sig'imi (izoxorali issiqlik sig'imi), $J / (kg \cdot ^\circ K)$.

Politrop jarayon issiqlik sig'imining hisob-kitobi uchun mo'ljallangan ifoda:

$$c = c_v \frac{k-n}{1-n} \quad (1.43)$$

bu yerda $k = c_p / c_v$ - adiabata ko'rsatkichi (Puasson koeffitsiyenti).

Asosiy termodinamik jarayonlar va ana shu jarayonlar uchun issiqlik sig'imi qiymati politropa ko'rsatkichining quyidagi qiymatlarida olinadi:

– izobarik jarayon $p = \text{const}$, $n = 0$.

$$p \cdot v^0 = p = \text{const}, \quad (1.44)$$

izobarali jarayon issiqlik sig'imi quyidagiga teng $c = c_p$;

– izoxorik jarayon $v = \text{const}$, $n = \pm\infty$.

$$p \cdot v^n = p^n \cdot v = v = \text{const} \quad (1.45)$$

izoxora jarayonning issiqlik sig'imi quyidagiga teng $c = c_v$;

– izotermik jarayoni $T = \text{const}$, $n = 1$.

$$p \cdot v^1 = p \cdot v = \text{const}, \quad (1.46)$$

izotermik jarayonning issiqlik sig'imi gaz kengayganida $c = +\infty$ ga va gaz torayganida $c = -\infty$ ga teng;

– adiabatali jarayon $\delta q = 0$, $n = k$.

$$p \cdot v^n = \text{const}, \quad (1.47)$$

adiabata jarayonining issiqlik sig'imi quyidagiga teng $c = 0$.

Ideal gazlar politrop jarayonlarining tahlili va hisobi termodinamika tenglamalari va qonunlari asosida o'tkazilib, o'z ichiga quyidagilarni oladi:

– jarayon boshlang'ich va so'nggi nuqtalari uchun p , v va T termik parametrlar hisobi;

– q jarayonda solishtirma ilqlik hisobi;

– hajm o'zgarganda ℓ ishining hisobi;

– ichki energiya Δu , entalpiya Δi va entropiya Δs o'zgarishining hisobi.

Yuqorida keltirilgan kattaliklarning hisobiy formulalari 1.3-jadvalda keltirilgan.

Ideal gazlar holati o'zgarishlari termodinamik jarayonlarining hisobiy formulalari

Jarayon	s	n	α	p, v, T	ℓ
$p = \text{const}$	c_p	0	$\frac{1}{k}$	$\frac{v}{T} = \text{const}$	$p \cdot \Delta v = R \cdot \Delta t$
$v = \text{const}$	c_v	$\pm\infty$	1	$\frac{p}{T} = \text{const}$	0
$T = \text{const}$	∞	1	0	$p \cdot v = \text{const}$	$RT \ln \frac{p_1}{p_2}$
$dq = 0$	0	k	∞	$p \cdot v^k = \text{const}$ $T \cdot v^{k-1} = \text{const}$ $T \cdot p^{\frac{1-k}{k}} = \text{const}$	$u_1 - u_2 = c_v \cdot (T_1 - T_2) = (p_1 v_1 - p_2 v_2) / (k - 1)$
Politropi			$\frac{1-n}{k-n}$	$p \cdot v^n = \text{const}$ $T \cdot v^{n-1} = \text{const}$ $T \cdot p^{\frac{1-n}{n}} = \text{const}$	

1.3-jadv. davomi

Jarayon	Δs	Q	$\Delta u, \Delta t$
$p = \text{const}$	$c_p \ln \frac{T_2}{T_1}$	$c_p \cdot \Delta t$	$\Delta u = c_v \Delta t, \Delta t = c_p \Delta t$
$v = \text{const}$	$c_v \ln \frac{T_2}{T_1}$	$c_v \cdot \Delta t$	
$T = \text{const}$	$R \ln \frac{p_1}{p_2}$	$RT \ln \frac{p_1}{p_2}$	
$dq = 0$	0	0	
Politropi	$c \cdot \ln(T_2/T_1)$	$c \cdot \Delta t$	

Ideal gaz holati o'zgarishining termik va energetik parametrlari hisobi p, v - va T, s - diagrammalarda jarayon grafigini qurish bilan to'ldirilishi lozim.

p, v - va T, s - diagrammalardagi 1,1 va 1.2-rasmlarda termodinamik jarayonlar tasvirlangan.

hisobga olib, termodinamikaning birinchi qonuni $\delta q = \delta \ell$ ko‘rinishga ega bo‘ladi, buning asosida hajm o‘zgarishining musbat ishi ($\delta \ell > 0$ kengayish ishi) issiqlik keltirilganida $\delta q > 0$, hamda mos ravishda, entropiya ortishi ($s \uparrow \Rightarrow ds > 0$) bilan yuz beradi deb xulosa qilish mumkin. Qisqacha qilib, izotermik kengayishda holat funksiyalari doimiy bo‘lib, termodinamik parametrlar, ish va issiqlik esa quyidagi tarzda o‘zgaradilar deb yozib olish mumkin:

$$T = \text{const}; v \uparrow; p \downarrow; u = i = \text{const}; s \uparrow \quad (1.48)$$

yoki:

$$\begin{aligned} dT = 0; dv > 0; dp < 0; du = 0; di = 0; ds > 0; \\ \delta \ell > 0; \delta q > 0; \delta q = \delta \ell. \end{aligned} \quad (1.49)$$

Ideal gazning izotermik siqilishida ($v \downarrow \Rightarrow dv < 0$) jarayon yo‘nalishi qarama-qarshi tomonga o‘zgaradi (1-2 jarayon), termodinamik parametrlar, ish va issiqlik o‘zgarishi esa bir-biriga teng bo‘ladi:

$$T = \text{const}; v \downarrow; p \uparrow; u = i = \text{const}; s \downarrow \quad (1.50)$$

yoki:

$$\begin{aligned} dT = 0; dv < 0; dp > 0; du = 0; di = 0; ds < 0; \\ \delta \ell < 0; \delta q < 0; \delta q = \delta \ell. \end{aligned} \quad (1.51)$$

Ideal gazlar holati o‘zgarish politrop jarayonining tahlili

Sharoitlar. Ideal ikki atomli gaz politropa ko‘rsatkichi $n = 0,4$ bo‘lgani holda politrop tarzda kengayib boradi.

Analiz. $p v^n = p v^{0,4} = \text{const}$ tenglamasidan politropa bo‘yicha $n = 0,4$ dan kengayishida gaz bosimi pasayishini ko‘rsatadi, chunki shartga ko‘ra $v_2 > v_1$.

Harorat o‘zgarishi $T v^{n-1} = T v^{-0,6} = T/v^{0,6} = \text{const}$ tenglamasi bo‘yicha aniqlanadi. Shartga binoan $v_2 > v_1$ bo‘lgani sababli, bu holda jarayon harorat oshishi bilan oqib o‘tadi $T_2 > T_1$, shuning uchun ichki energiya $u_2 > u_1$ ($\Delta u > 0$) va entalpiya $i_2 > i_1$ ($\Delta i > 0$) oshgan holda kechadi.

Termodinamikaning birinchi qonuni tenglamasiga muvofiq $dq = du + d\ell$, chunki $du > 0$ va $d\ell > 0$ (shartga binoan), $du > 0$, bu holda $dq > 0$. Tadqiq etilayotgan jarayonda issiqlik keltirilishda davom etadi, bundan kelib chiqib, entropiya kattalashaveradi.

Ideal gaz kengayishining politropa ko'rsatkichi $n = 0,4$ bo'lgan politrop jarayonini p, v - va T, s - diagrammalarda 1.4-rasmda tasvirlaymiz.

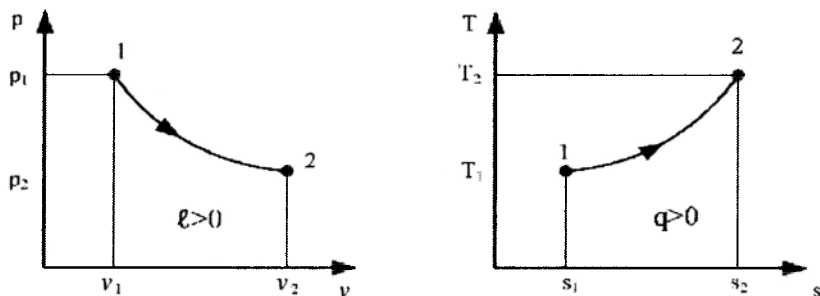

1.4-rasm. Ideal gazning p, v - va T, s - diagrammalardagi politrop kengayish jarayoni ($n=0,4$).

1.21-masala. Boshlang'ich parametrlari $p_0 = 10$ bar va $t_0 = 350$ °C bo'lgan 1 kg azot ($\mu = 28$ kg / kmol) kengayadi. Bunda gaz hajmi 4,5 marta kattalashadi.

Gazning kengayish jarayonlari:

- a) izobarali;
- b) izotermik;
- c) adiabatali.

Issiqlik miqdori, hajmning o'zgarish ishi va ichki energiya o'zgarishi va entropiya o'zgarishi aniqlansin.

Jarayonlar p, v - va T, s - diagrammalarda tasvirlansin.

Yechim: p, v - va T, s - diagrammalardagi jarayonlar 1.5-rasmda tasvirlangan.

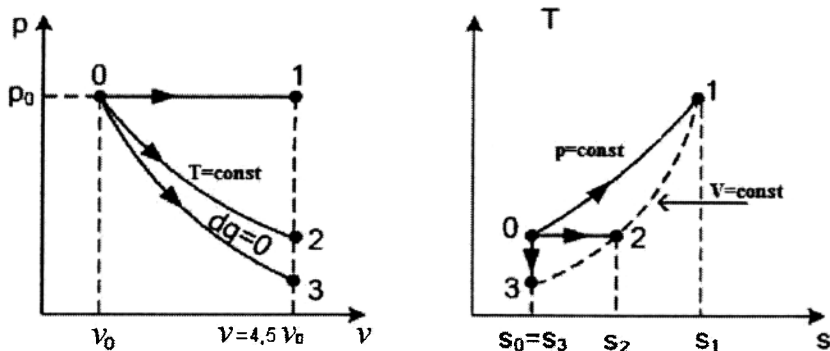

1.5-rasm. Gazning kengayish jarayoni:

0-1 - ideal gaz kengayishining izobarali jarayoni;

0-2 - ideal gaz kengayishining izotermik jarayoni;

0-3 - ideal gaz kengayishining adiabatali jarayoni.

a) Izobarali jarayon $p = \text{const}$

Shartga ko'ra $p_0 = 10 \text{ bar}$, $T_0 = 350 + 273 = 623 \text{ }^\circ\text{K}$.

$P = \text{const} - T_1 / T_0 = v_1 / v_0 = 4,5$ bo'lganida.

Gazning oxirgi harorati

$T_1 = 4,5 \cdot T_0 = 4,5 \cdot 623 = 2803 \text{ }^\circ\text{K} \approx 2530 \text{ }^\circ\text{C}$.

Izobarali jarayondagi issiqlik miqdori

$q = c_p \cdot (t_1 - t_0) = 1,04 \cdot (2530 - 350) = 2267 \text{ kJ/kg}$,

bu yerda yalpi izobarali issiqlik sig'imi:

$$c_p = 4,157 \cdot \frac{(i + 2)}{\mu} = 4157 \cdot \frac{7}{28} = 1,04 \frac{\text{kJ}}{\text{kg} \cdot ^\circ\text{K}}$$

Hajm o'zgarganda bajarilayotgan ish:

$$\ell = R \cdot (t_1 - t_0) = 0,2969 \cdot (2530 - 350) = 647 \text{ kJ/kg}$$

bu yerda gaz doimiysi:

$$R = \frac{R_\mu}{\mu} = \frac{8314}{28} = 296,9 \frac{\text{kJ}}{\text{kg} \cdot ^\circ\text{K}} = 0,2969 \frac{\text{kJ}}{\text{kg} \cdot ^\circ\text{K}}$$

Izobarali jarayon uchun hajm o'zgarganda bajarilayotgan ish quyidagi formula bo'yicha ham aniqlanishi mumkin:

$$\ell = p \cdot (v_1 - v_0) = 10^3 \cdot (0,8323 - 0,1850) = 647 \text{ kJ / kg,}$$

bu yerda shartga binoan $v_0 = R T_0 / p_0, v_1 = 4,5 v_0$
 $v_0 = 296,9 \cdot 623 / 10^6 = 0,1850 \text{ m}^3 / \text{kg}$
 $v_1 = 4,5 \cdot 0,1850 = 0,8323 \text{ m}^3 / \text{kg}$

Ichki energiya o'zgarishi

$$u_1 - u_0 = c_v \cdot (t_1 - t_0) = 0,742 \cdot (2530 - 350) = 1618 \text{ kJ / kg,}$$

$$c_v = 4,157 \cdot \frac{i}{\mu} = 4157 \cdot \frac{5}{28} = 0,742 \frac{\text{kJ}}{\text{kg} \cdot \text{°K}}.$$

bu yerda

Tekshirish:

$q = \Delta u + \ell = 1618 + 647 = 2265 \text{ kJ / kg.}$ (xatolik taxminan 0,09 foizni tashkil etadi)

Entropiya o'zgarishi

$$\Delta s = c_p \cdot \ln \frac{T_1}{T_0} = 1,04 \cdot \ln \frac{2803}{623} = 1,56 \frac{\text{kJ}}{\text{kg} \cdot \text{°K}}.$$

Yakuniy bosim: $p_1 = p_0 = 10 \text{ bar.}$

b) Izotermik jarayon $T = \text{const}$

Shartga ko'ra $p_0 = 10 \text{ bar, } T_2 = T_0 = 623 \text{ °K, } v_2 / v_0 = 4,5.$

$T = \text{const } pv = \text{const}$ va $p_0 / p_2 = 4,5$ bo'lganida.

Yakuniy bosim $p_2 = p_0 / 4,5 = 10 / 4,5 = 2,22 \text{ bar.}$

$T = \text{const}$ bo'lganida $u = \text{const}$ va $\Delta u = 0$, ya'ni gazning ichki energiyasi o'zgarmaydi.

Izotermik jarayondagi issiqlik miqdori hajm o'zgarishiga teng.

$$q = l = R \cdot T \cdot \ln \frac{p_2}{p_0} = R \cdot T \cdot \ln \frac{v_2}{v_0} = 0,2969 \cdot 623 \cdot \ln 4,5 = 278,2 \text{ kJ/kg}$$

Entropiya o'zgarishi

$$\Delta s = q / T = 278,2 / 623 = 0,446 \text{ kJ / (kg} \cdot \text{°K).}$$

c) Adiyatik jarayon $dq = 0$

$P_0 = 10 \text{ bar, } T_0 = 623 \text{ °K}$ shartiga ko'ra, $v_1 / v_0 = 4,5.$

Adiabatik jarayon tenglamasi $p v^k = \text{const}$ bo'lib, unda ikki atomli gazlar uchun ($i = 5$) adiabata ko'rsatkichi:

$$k = \frac{c_p}{c_v} = \frac{i + 2}{1} = 1,4$$

Yakuniy bosim $p_3 = p_0 (v_0 / v_3)^k = 10 (1 / 4,5)^{1,4} = 10 / 4,5^{1,4} = 1,22 \text{ bar}$.

Yakuniy harorat quyidagi tenglamaga ko'ra aniqlanadi $T v^{k-1} = \text{const.}$:

$$T_3 = T_0 (v_0 / v_3)^{k-1} = 623 (1 / 4,5)^{1,4-1} = 623 / 4,5^{0,4} = 327,2 \text{ }^\circ\text{K} = 54,2 \text{ }^\circ\text{C}$$

Adiabatik jarayon uchun: $q = 0, \Delta s = 0, s = \text{const}$.

Hajmning o'zgaranda bajariladigan ish

$$\ell = -\Delta u = u_0 - u_3 = c_v \cdot (t_0 - t_3) = 0,742 \cdot (350 - 54,2) = 219,5 \text{ kJ / kg}$$

Javob: a) $q = 2267 \text{ kJ / kg}$;

$$\ell = 647 \text{ kJ / kg}$$

$$\Delta u = 1618 \text{ kJ/kg}$$

$$\Delta s = 1,56 \text{ kJ/(kg} \cdot \text{ }^\circ\text{K)}$$

b) $q = \ell = 278,2 \text{ kJ / kg}$;

$$\Delta u = 0$$

$$\Delta s = 0,446 \text{ kJ / (kg} \cdot \text{ }^\circ\text{K)}$$

c) $q = 0$;

$$\ell = -\Delta u = 219,5 \text{ kJ / kg}$$

$$\Delta s = 0$$

1.22-masala. 1 m^3 havo ($\mu = 28,96 \text{ kg / kmol}$) boshlang'ich parametrlari $p_1 = 10 \text{ bar}$ va $t_1 = 180 \text{ }^\circ\text{C}$ politropa bo'yicha $p_2 = 1 \text{ bar}$ gacha kengayadi va $t_2 = 72 \text{ }^\circ\text{C}$ gacha isiydi. 1 m^3 havodan olingan issiqlik miqdori, hajmning o'zgarish ishi, ichki energiyaning o'zgarishi aniqlansin.

Yechim: Tenglamadan politropa ko'rsatkichini topamiz:

$$T_1 \cdot p_1^{\frac{1-n}{n}} = T_2 \cdot p_2^{\frac{1-n}{n}}; \quad \frac{T_1}{T_2} = \left(\frac{p_2}{p_1} \right)^{\frac{1-n}{n}}$$

$$\ln \left(\frac{T_1}{T_2} \right) = \frac{1-n}{n} \cdot \ln \left(\frac{p_2}{p_1} \right); \quad \frac{1-n}{n} = \frac{\ln \left(\frac{453}{345} \right)}{\ln \left(\frac{1}{10} \right)}$$

$$0,272 \cdot n = (1-n) \cdot (-2,08) \quad n = 1,15$$

Havo massasi:

$$m = \frac{p_1 \cdot V_1}{R \cdot T_1} = \frac{10 \cdot 10^5}{287 \cdot (273 + 180)} = 7,69 \text{ kg},$$

bu yerda:

$$R = \frac{R_\mu}{\mu} = \frac{8314}{28,96} = 287 \frac{\text{J}}{\text{kg} \cdot \text{°K}}.$$

Issiqlik miqdori:

$$Q = m \cdot q = m \cdot c \cdot (t_2 - t_1) = 7,69 \cdot (-1,0766) \cdot (72 - 180) = 894,14 \text{ kJ},$$

bu yerda

$$c = c_v \cdot \frac{n - k_1}{n - 1} = R \cdot \frac{i}{2} \cdot \frac{n - k}{n - 1} = \frac{8,314}{28,96} \cdot \frac{5}{2} \cdot \frac{1,15 - 1,4}{1,15 - 1} = -1,0766 \frac{\text{kJ}}{\text{kg} \cdot \text{°K}}.$$

Hajm o'zgarganda bajarilgan ish:

$$L = m \cdot \ell = m \cdot \frac{R}{n - 1} \cdot (t_1 - t_2) = 7,69 \cdot \frac{0,287}{1,15 - 1} \cdot (180 - 72) = 1589,06 \text{ kJ}$$

Ichki energiya o'zgarishi:

$$\Delta U = m \cdot \Delta u = m \cdot c_v \cdot (t_2 - t_1) = 7,69 \cdot \frac{8,314}{28,96} \cdot \frac{5}{2} \cdot (72 - 180) = -596,07 \text{ kJ}$$

Javob: $n = 1,15$; $Q = 894,14 \text{ kJ}$; $L = 1589,06 \text{ kJ}$;

$\Delta U = -596,07 \text{ kJ}$.

1.23-masala. Havo politropa bo'yicha $n = 1,2$ dan $p_1 = 6 \text{ bar}$ va $t_1 = 320 \text{ °C}$ $p_2 = 1 \text{ bar}$ gacha ko'rsatkichi bilan kengayadi. Jarayon boshlang'ich va so'nggi nuqtalar parametrlari, issiqlik sarfi, 1 kg havoga hajmning o'zgarish ishi aniqlansin va jarayon p, v - va T, s - diagrammalarda ifodalansin.

Javob: $v_1 = 0,284 \text{ m}^3 / \text{kg}$; $v_2 = 1,26 \text{ m}^3 / \text{kg}$; $T = 439 \text{ K}$;

$q_{1,2} = 110,6 \text{ kJ} / \text{kg}$; $\ell = 220,6 \text{ kJ} / \text{kg}$.

1.24-masala. Gaz aralashmasi massasi bo'yicha quyidagi tarkibga ega: $\text{H}_2 = 10\%$, $\text{CO}_2 = 10\%$, $\text{CH}_4 = 30\%$, $\text{N}_2 = 50\%$. Aralashmaning boshlang'ich parametrlari $p_1 = 2 \text{ bar}$, $t_1 = 27 \text{ °C}$. Agar aralashma adiabatik tarzda $p_2 = 10 \text{ bar}$ gacha siqilsa, oxirgi harorat va siqilish ishi aniqlansin. Jarayon p, v - va T, s - diagrammalarda tasvirlansin.

Javob: $t_2 = 195 \text{ }^\circ\text{C}$; $\ell = -325 \text{ kJ / kg}$.

1.25-masala. Massasi 1,5 kg bo'lgan havo siqiladi politropno $p_1 = 0,09 \text{ MPa}$ dan va $t_1 = 18 \text{ }^\circ\text{C}$ $p_2 = 1 \text{ MPa}$ gacha. Harorat bunda $t_2 = 125 \text{ }^\circ\text{C}$ ga qadar ko'tariladi. Politropa ko'rsatkichi, yakuniy hajm, sarflangan ish va ajratilgan issiqlik miqdori aniqlansin. Jarayon p, v - va T, s - diagrammalarda tasvirlansin.

Javob: $n = 1,149$; $V_2 = 0,171 \text{ m}^3$; $L = -309,2 \text{ kJ}$; $Q = -195,4 \text{ kJ}$.

1.26-masala. U uchun uch nuqta parametrlari quyidagi qiymatlarga ega bo'lgan gazning siqilish jarayoni politropali bo'la olish-olmasligi aniqlansin: $p_1 = 0,12 \text{ MPa}$, $t_1 = 30 \text{ }^\circ\text{C}$; $p_2 = 0,36 \text{ MPa}$, $t_2 = 91 \text{ }^\circ\text{C}$; $p_3 = 0,54 \text{ MPa}$, $t_3 = 116 \text{ }^\circ\text{C}$. Jarayon p, v - va T, s - diagrammalarda tasvirlansin.

Javob: jarayon politropali $n = 1,2$.

1.27-masala. Massasi 1 kg bo'lgan kislorod boshlang'ich bosim 2 MPa va 300 °C haroratda politrop tarzda 0,25 MPa bosimga qadar kengayadi. Oxirgi hajm 0,35 m³ / kg. Jarayonning issiqlik miqdori, hajm o'zgarishdagi ishi, ichki energiya, entalpiya va entropiya o'zgarishi aniqlansin. Jarayon p, v - va T, s - diagrammalarda tasvirlansin.

Javob: $q = 28,1 \text{ kJ / kg}$; $\Delta u = -153,4 \text{ kJ / kg}$;
 $\ell = 181,5 \text{ kJ / kg}$; $\Delta i = -224,2 \text{ kJ / kg}$;
 $\Delta s = 0,066 \text{ kJ / (kg} \cdot \text{ }^\circ\text{K)}$.

1.28-masala. 4 m³ hajmni egallagan va boshlang'ich harorat 20 °C ga ega bo'lgan karbonat anhidrid, doimiy hajmda kengayib boradi. Bunda uning bosimi 0,1 MPa dan 0,3 MPa gacha oshadi. Shundan so'ng gaz adiabat bo'yicha 0,15 MPa gacha kengayadi. Har bir jarayon uchun issiqlik miqdori, hajmning o'zgarish ishi, ichki energiya o'zgarishi, entropiya va entalpiya o'zgarishi aniqlansin. Jarayonlar p, v - va T, s - diagrammalarda tasvirlansin.

Javob: a) $L = 0$; $Q = 2398,9 \text{ kJ}$;
 $\Delta I = 3198,5 \text{ kJ}$;
 $\Delta S = 4,498 \text{ kJ / K}$;
 $\Delta U = Q = 2398,9 \text{ kJ}$.
b) $Q = 0$; $L = 570 \text{ kJ}$;
 $\Delta U = -570 \text{ kJ}$;
 $\Delta I = -758 \text{ kJ}$; $\Delta S = 0$.

1.4. Suv va suv bug'ı xossalari. Suv bug'ı jarayonlari

Suv uch xil faza holatida bo'lishi mumkin: qattiq – muz, suyuq – suv va gazsimon – bug'.

Suv bug'ı – real gaz, uning holat parametrlari va funksiyalari orasidagi bog'liqlik faqat tajriba yo'li bilan topilgan. Eksperimentlar natijalari jadvallar va diagrammalar ko'rinishida taqdim etilgan. Suyuqlik bug'lanish va qaynash ko'rinishida bug'ga aylanishi mumkin.

Bug'lanish – qattiq yoki suyuq faza yuzasida bug' hosil bo'lishi.

Qaynash – suyuqlik hajmida bug' hosil bo'lishi – hajmiy qaynash, yoki suyuqlik qatlami ostida qattiq yuzada – yuzada qaynash.

Suv bug'ining uch holati mavjud:

- nam to'yingan suv bug'ı;
- quruq to'yingan suv bug'ı;
- ortiqcha qizdirilgan suv bug'ı.

Ikki fazali aralashma suyuqlik – to'yingan holatdagi bug' to'yingan holdagi nam suv bug'ı deb nomlanadi.

To'yingan nam suv bug'ining massasi suyuqlik va quruq bug' yig'indisiga teng bo'ladi:

$$m = m_s + m_b, \quad (1.52)$$

bu yerda m_s – suyuqlik massasi, kg;

m_b – bug' massasi, kg.

Tarkibida suyuqlik bo'lmagan to'yingan suv bug'ı quruq to'yingan suv bug'ı deb ataladi ($m_s = 0$).

Suyuqlik qaynashi va suv bug'ining kondensatsiyalanishi ro'y beradigan harorat va bosim to'yinish harorati va to'yinish bosimi deb nomlanadi. Shu bosimda to'yinish bosimi haroratidan yuqori haroratli bug' ortiqcha qizdirilgan (qizdirib yuborilgan) suv bug'ı deb ataladi.

To'yingan nam suv bug'iga tavsif berish uchun bug'ning quruqlik darajasi tushunchasi kiritilib, u to'yingan quruq bug' massasining m_b suyuqlik – bug' ikki fazali aralashmasining massasi nisbatiga teng:

$$x = \frac{m_b}{m} \quad (1.53)$$

bu yerda $m = m_s + m_b$ – nam bug' massasi, kg.

Quruqlik darajasi noldan birgacha bo'lgan oraliqda o'zgaradi $0 \leq x \leq 1$. $x = 0$ bo'lganida suv qaynayotgan suyuqlik, $x = 1$ bo'lganida esa quruq to'yingan suv bug'i holatida bo'ladi.

Suyuqlik massasining to'yingan nam suv bug'ining massasiga nisbatini namlik darajasi deb ataydilar:

$$1 - x = \frac{m_s}{m} \quad (1.54)$$

Fazaviy holatni va holat parametrlari qiymatlarini suv va suv bug'ining termodinamik xossalari jadvallari bo'yicha aniqlanadi [8,14].

Suv va suv bug'i xossalarining jadvallari p-t diagrammasidagi nuqtalari uchun olingan tajriba ma'lumotlarini approksimatsiyalash yo'li bilan olingan. 1 va 2-jadvallarda [8,14] to'yinish chizig'idagi suyuqlik va bug' solishtirma hajmlari, entalpiya va entropiyasi hamda bug' hosil bo'lishi solishtirma issiqligining qiymatlari keltirilgan. Keltirilgan kattaliklar haroratga [8, 1-jadv.] hamda bosimga [8, 2-jadv.] bog'liq holda berilgan.

Suyuqliklar va ortiqcha qizdirilgan bug' uchun solishtirma hajmlar, entalpiya va entropiya qiymatlari haroratga bog'liq holda izobaralar bo'yicha 3-jadvalda berilgan [8,14].

Jadvallarda ichki energiya qiymati berilmagan, shu sababli ichki energiya formula bo'yicha hisoblab topiladi:

$$u = i - p \cdot v, \quad (1.55)$$

bu yerda i – entalpiya, kJ / kg;

p – bosim, kPa;

v – solishtirma hajm, m³ / kg.

Suv va suv bug'ining tajribalar orqali topilgan xossalari oltita jadval ko'rinishida keltirilgan.

1-jadval. Suvning termodinamik xossalari i suv bug'ining to'yingan holatdagi (argument - harorat);

2-jadval. Suvning termodinamik xossalari i suv bug'ining to'yingan holatdagi (argument - bosim);

3-jadval. Suv va ortiqcha qizdirilgan bug'ning termodinamik xossalari;

4-jadval. Suv va suv bug'ining massasining haqiqiy izobarik issiqlik sig'imi;

5-jadval. Suv va suv bug'ining dinamik qovushqoqligi;

6-jadval. Suv va suv bug‘ining issiqlik o‘tkazuvchanligi.

Suv va suv bug‘ining termodinamik xossalari jadvallarida keltirilgan ma’lumotlar asosida diagrammalar qurilgan bo‘lib, ular suv, to‘yingan nam suv bug‘ining va ortiqcha qizigan bug‘ holatlarini yaqqol ko‘rsatadilar. Bundan tashqari diagrammalar yordamida suv va suv bug‘i holatining o‘zgarish jarayonlarini tasvirlash va issiqlik - energetika uskunalari sikllarining muhandislik hisoblarini amalga oshirish mumkin.

Termodinamik hisob - kitoblarda eng ko‘p qo‘llanadigan suv va suv bug‘ining koordinatalarda qurilgan diagrammalarini ko‘rib chiqamiz: bosim - solishtirma hajm ($p-v$), mutlaq harorat - solishtirma entropiya ($T-s$) va solishtirma entalpiya - solishtirma entropiya ($i-s$). Fazaviy diagrammalar p,v -, T,s - va i,s - mos ravishda 1.6, 1.7 va 1.8-rasmlarda tasvirlangan.

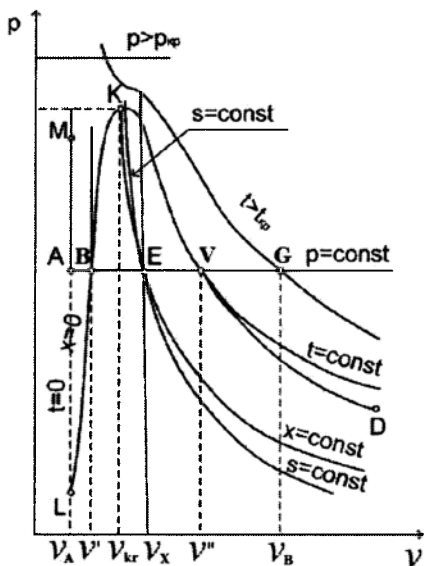

1.6-rasm. Suv bug‘ining fazaviy (p, v) - diagrammasi

Diagrammalarda kritik nuqta K quyidagi parametrlarga ega:

- kritik bosim $p_{kr} = 22,129 \text{ MPa}$;
- kritik harorat $t_{kr} = 374,16 \text{ }^\circ\text{C}$;
- kritik solishtirma hajm $v_{kr} = 0,00326 \text{ m}^3 / \text{kg}$.

Bu nuqtada suvning suyuq va bug' holatidagi fazalar orasidagi farqlar yo'qoladi.

Kritik nuqtada quyi chegaraviy nuqta KL va yuqori chegaraviy nuqta KD birlashadilar. Chegaraviy egri chiziqlar diagramma ko'rinishini 3 qismga ajratib turadilar:

– KL egri chizig'idan chaproqda tomchili suyuqlik holatidagi suv joylashgan;

– KD egri chizig'idan o'ngroqda ortiqcha qizigan bug' holati joylashgan;

– KL va KD egri chiziqlari orasida to'yingan nam suv bug'i joylashgan.

Quyi chegaraviy egri chiziqning barcha nuqtalarida suv to'yinish haroratida qaynash holatida bo'ladi, shu sababli KL chizig'ini, shuningdek, qaynayotgan suyuqlik egri chizig'i deb ham ataladi.

Yuqori chegara egri chiziqning barcha nuqtasida modda to'yingan quruq suv bug'i holatida bo'lib, shu sababli KD chizig'ini quruq to'yingan bug' chizig'i ham deb ataladi.

Chegaraviy egri chiziqlardan yuqorida joylashgan soha paytida suyuqlik va bug' o'rtasida yaqqol farq mavjud bo'lmagan suvning o'ta kritik holatini aks ettiradi.

Diagrammalarda izobara, izoxora, izoterma, adiabatlar va quruqlik darajasining doimiysi chiziqlari tasvirlangan. Moddaning qaynayotgan suyuqlik chizig'idagi quruqlik darajasi $x = 0$ bo'lganidagi parametrlari $x = 0$ «bitta shtrix» yuqori indeksi bilan belgilanadi. Masalan, v, s, i va sh.k. To'yingan quruq suv bug'i chizig'ida modda parametrlari quruqlik darajasi $x = 1$ bo'lganida «ikki shtrix» yuqori indeksi bilan belgilanadi. Masalan, v, s, i va sh.k.

To'yingan nam suv bug'i parametrlari x quruqlik darajasiga to'g'ri proporsional bog'liqlik formulalari bo'yicha hisoblab topiladi. Masalan, to'yingan nam suv bug'ining solishtirma hajmini hisob - kitob qilish uchun formula quyidagi ko'rinishga ega:

$$v_x = x \cdot v'' + (1 - x) \cdot v' \quad (1.56)$$

yoki:

$$v_x = v' + x \cdot (v'' - v'), \quad (1.57)$$

bu yerda $v' - x = 0$ chizig'idagi qaynayotgan suyuqlik egri chizig'idagi solishtirma hajmning parametrlari, $v - x = 1$ chizig'idagi to'yingan quruq suv bug'ining solishtirma hajmining parametrlari.

O'ta qizigan bug' parametrlari va holati funksiyalari indeksiz belgilanadi. Masalan, v, s, i va sh.k.

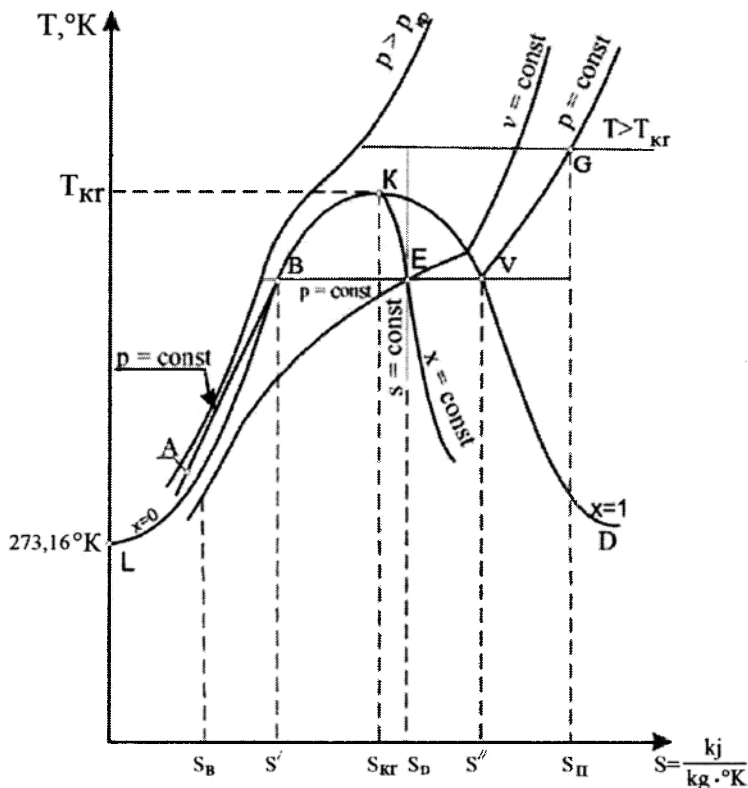

1.7-rasm. Suv bug'ining fazaviy (T, s) – diagrammasi

Suvning fazaviy holatining o'zgarishini tahlil qilish uchun barcha uchta diagrammada (1.6-rasm, 1.7-rasm va 1.8-rasm) suvning izobarali isitilish jarayoni ABEVG tasvirlangan. AB uchastkasida suvning tomchili suyuqlik holatida shu bosim t_n da to'yinish haroratiga qadar isishi yuz

beradi. Egri chiziqning quyi chegarasida joylashgan V nuqtasida, suv to‘yinish haroratida qaynaydi. BV uchastkasi – to‘yingan nam suv bug‘i uchastkasida – tomchili suyuqlikning (B n.) quruq to‘yingan suv bug‘ining holatiga (V n.) o‘tishi ro‘y beradi. V nuqtasi egri chiziqning yuqori chegarasida joylashadi. Bug‘ hosil bo‘lish jarayoni doimiy to‘yinish bosimida p_n va doimiy to‘yinish haroratida t_n ro‘y beradi. Issiqlik kelib tushishda davom etganida suv bug‘ining bu bosimda qizib ketishi – ya‘ni VG jarayoni yuz beradi.

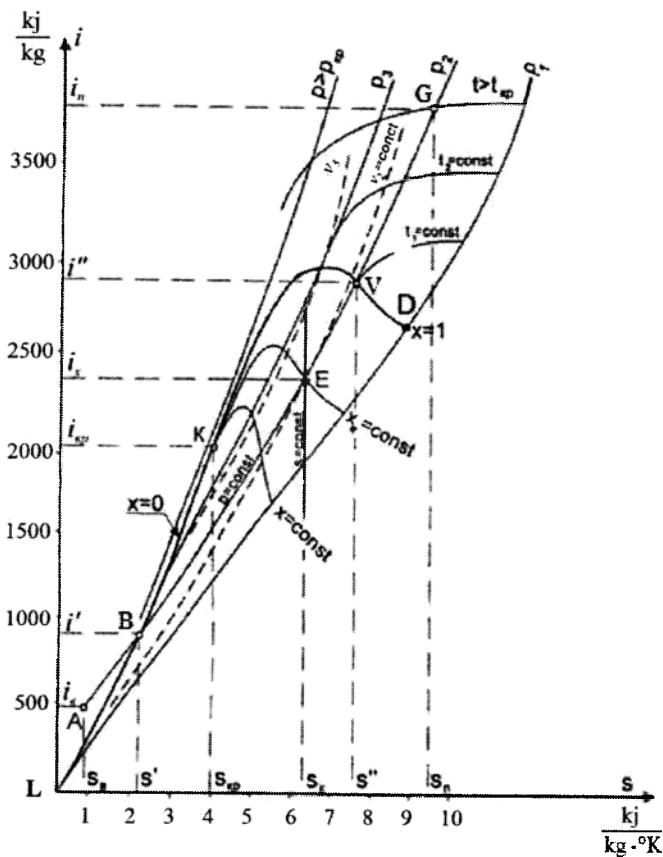

1.8-rasm. Suv bug‘ining fazaviy (i, s) – diagrammasi

T,s – diagrammada AB egri chiziq ostidagi maydon suvni to‘yinish holati q_v ga qadar isitishga sarflanadigan issiqlikka teng. BV egri chizig‘i ostidagi maydon fazaviy o‘tish r issiqligiga teng. VG egri chizig‘i ostidagi maydon q_{per} bug‘ni ortiqcha isitishga sarflanadigan issiqlikka teng.

p,v - diagrammada LM izoterma $t = 0\text{ }^{\circ}\text{C}$ suvning deyarli siqilmasligi hisobiga bir vaqtning o‘zida izoxora ham bo‘lib keladi.

Fransuz muhandisi R. Molye tomonidan 1904-yilda taklif etilgan i,s - diagrammasi issiqlik energetika uskunalarini sikllarini tahlil va hisob - kitob qilish uchun keng qo‘llanadigan bo‘ldi. i,s - diagrammaning ustun jihati izobarali jarayonda sarflanadigan, diagrammadagi ordinatalar farqiga teng bo‘lgan issiqlik miqdorining hisob-kitob qilish qulayligida.

Suv bug‘ining jarayonlarini hisob - kitob qilishda quyidagi harakatlar bajariladi:

- suv va suv bug‘ining boshlang‘ich va so‘nggi parametrlari topiladi;
- issiqlik miqdori va hajmning o‘zgarish ishi hisoblab topiladi;
- T,s - va i,s - diagrammalarda masshtabsiz, ammo berilgan shartlarga muvofiq jarayonlar quriladi.

Suv va suv bug‘ining parametrlari esa suv va suv bug‘ining termodinamik xossalari jadvallari va i,s – diagrammasi bo‘yicha aniqlanadi.

Suv bug‘i holatining asosiy o‘zgarish jarayonlarini hisob-kitob qilish formulalari 1.4-jadvalda keltirilgan.

1.4-jadval

Suv bug‘i holati o‘zgarish jarayonlarining hisobi

Jarayon	Q	ℓ
$p = \text{const}$	$q = i_2 - i_1$	$\ell = p \cdot (v_2 - v_1)$
$v = \text{const}$	$q = u_2 - u_1 = (i_2 - i_1) - v \cdot (p_2 - p_1)$	$\ell = 0$
$T = \text{const}$	$q = T \cdot (s_2 - s_1)$	$\ell = q - \Delta u = q - (u_2 - u_1),$ $u_2 - u_1 = (i_2 - i_1) - (p_2 \cdot v_2 - p_1 \cdot v_1)$
$dq = \text{const}$ $s = \text{const}$	$q = 0$	$\ell = u_1 - u_2 = (i_1 - i_2) - (p_1 \cdot v_1 - p_2 \cdot v_2)$

1.29-masala. 1,5 MPa bosimda to‘yingan quruq suv bug‘ining harorati, solishtirma hajmi, zichligi, entropiyasi, entalpiyasi aniqlansin.

Yechim: $p = 1,5 \text{ MPa} = 1,5 \cdot 10^6 \text{ Pa}$ [8, 2-jadv.] bo'lganida to'yingan quruq bug'ning parametrlari:

solishtirma hajm $v'' = 0,13170 \text{ m}^3 / \text{kg}$;

entalpiya $i'' = 2791,0 \text{ kJ} / \text{kg}$;

entropiya $s'' = 6,4431 \text{ kJ} / (\text{kg} \cdot ^\circ\text{K})$.

To'yingan quruq bug'ning harorati to'yinish haroratiga teng va $198,30 \text{ }^\circ\text{C}$ ni tashkil qiladi.

To'yingan quruq bug'ning zichligi

$P = 1/v = 1/0,13170 = 7,633 \text{ kg} / \text{m}^3$.

1.30-masala. Suvning fazaviy holati va uning $p = 2,5 \text{ MPa}$ va $t = 120 \text{ }^\circ\text{C}$ bo'lganidagi parametrlari aniqlansin.

Yechim: $p = 2,5 \text{ MPa}$ bo'lganida suvning qaynash harorati $t = t_n = 223,96 \text{ }^\circ\text{C}$. Shartga ko'ra $t < t_n$ bo'lganligi sababli, bu holda suvning fazaviy holati – qaynashgacha isitilmagan suyuqlik. [8; 3-jadv.] ga binoan $p = 2,5 \text{ MPa}$ va $t = 120 \text{ }^\circ\text{C}$ bo'lganida suv parametrlari:

$v = 0,0010590 \text{ m}^3 / \text{kg}$;

$i = 505,4 \text{ kJ} / \text{kg}$;

$s = 1,5257 \text{ kJ} / (\text{kg} \cdot ^\circ\text{K})$.

1.31-masala. 4 m^3 hajmli idishda $0,3 \text{ MPa}$ bosimda 8 kg suv bug'i bor. Bug' parametrlari aniqlansin.

Yechim: Bug'ning solishtirma hajmi $v = V/m = 0,5 \text{ m}^3 / \text{kg}$.

$P = 0,3 \text{ MPa} = 3 \cdot 10^5 \text{ Pa}$ bo'lganida suv va suv bug'ining termodinamik xossalari jadvallariga ko'ra [8; 2-jadv.]:

qaynayotgan suyuqlikning solishtirma hajmi $v' = 0,0010732 \text{ m}^3 / \text{kg}$,

to'yingan quruq bug'ning solishtirma hajmi $v'' = 0,060579 \text{ m}^3 / \text{kg}$.

$v = 0,5 \text{ m}^3 / \text{kg}$, ya'ni $v' < v < v''$ bo'lganligi sababli, suv bug'ining fazaviy holati – nam to'yingan bug'.

Quruqlik darajasi

$$x = \frac{v_x - v'}{v'' - v'} = \frac{0,5 - 0,0010732}{0,060579 - 0,0010732} = 0,825$$

$p = 3 \cdot 10^5 \text{ Pa}$ bosimda [8, 2-jadv.] ga binoan:

$i' = 561,5 \text{ kJ} / \text{kg}$;

$i'' = 2724,9 \text{ kJ} / \text{kg}$;

$s' = 1,6718 \text{ kJ} / \text{kg} \cdot ^\circ\text{K}$;

$s'' = 6,9916 \text{ kJ} / \text{kg} \cdot ^\circ\text{K}$.

Bug' entalpiyasi

$$i_x = i' + x \cdot (i'' - i') = 561,5 + 0,825 (2724,9 - 561,5) = 2346,3 \text{ kJ / kg.}$$

Bug' entropiyasi

$$s_x = s' + x \cdot (s'' - s') = 1,6718 + 0,825 \cdot (6,9916 - 1,6718) = 6,06 \text{ kJ / kg } ^\circ\text{K.}$$

$$p = 0,3 \text{ MPa bo'lganida to'yinish harorati } t_n = 133,53 \text{ } ^\circ\text{C.}$$

$$\text{Javob: } i_x = 2346,3 \text{ kJ / kg;}$$

$$s_x = 6,06 \text{ kJ / kg;}$$

$$t_n = 133,53 \text{ } ^\circ\text{C.}$$

1.32-masala. $P = 8 \text{ MPa}$ va $t = 410 \text{ } ^\circ\text{C}$ bo'lganida suv bug'ining ichki energiyasi aniqlansin.

$$\text{Yechim: } P = 8 \text{ MPa bo'lganida to'yinish harorati } t_n = 295,01 \text{ } ^\circ\text{C.}$$

$P = 8 \text{ MPa} = 8 \cdot 10^3 \text{ kPa}$ va $t = 410 \text{ } ^\circ\text{C}$ bo'lganida qizib ketgan suv bug'ini [8, 3-jadv.] quyidagicha aniqlaymiz:

$$i = 3167 \text{ kJ / kg;}$$

$$v = 0,03515 \text{ m}^3 / \text{kg.}$$

Ichki energiya $u = i - pv$.

$$u = 3167 - 8 \cdot 10^3 \cdot 0,03515 = 2885,8 \text{ kJ / kg.}$$

$$\text{Javob: } u = 2885,8 \text{ kJ / kg.}$$

1.33-masala. Harorati $120 \text{ } ^\circ\text{C}$ bo'lgan 1 kg suv 5 MPa doimiy bosim bilan isitilib, $440 \text{ } ^\circ\text{C}$ harorat bilan bug'ga aylanadi. Suvni qaynashga qadar, bug' hosil qilish jarayoniga, bug'ni ortiqcha qizdirishga, jarayonning umumiy issiqligiga, bug'ning ortiqcha qizdirilish darajasiga va hajmi o'zgartirish ishiga sarflanadigan issiqlik miqdori, boshlang'ich va oxirgi parametrlari aniqlansin.

Yechim: $P = 5 \text{ MPa} = 5 \cdot 10^6 \text{ Pa}$ bo'lganida to'yinish harorati $t_n = 263,94 \text{ } ^\circ\text{C}$ ga teng. [8, 3-jadv.] ga binoan $p_1 = 5 \text{ MPa}$ va $t_1 = 120 \text{ } ^\circ\text{C}$ bo'lganida suvning boshlang'ich parametrlari:

$$i_1 = 507,2 \text{ kJ / kg; } s_1 = 1,5235 \text{ kJ / kg } ^\circ\text{K; } v_1 = 0,0010588 \text{ m}^3 / \text{kg.}$$

$$u_1 = i_1 - p_1 \cdot v_1 = 507,2 - 5 \cdot 10^3 \cdot 0,0010588 = 501,906 \text{ kJ / kg}$$

$p_2 = p_1 = 5 \text{ MPa}$ va $t_2 = 440 \text{ } ^\circ\text{C}$ bo'lganida ortiqcha qizigan suv bug'ining so'nggi parametrlari:

$$i_2 = 3293,3 \text{ kJ / kg; } s_2 = 6,7877 \text{ kJ / kg } ^\circ\text{K; } v_2 = 0,06225 \text{ m}^3 / \text{kg.}$$

$$u_2 = i_2 - p_2 \cdot v_2 = 3293,3 - 5 \cdot 10^3 \cdot 0,06225 = 2982,05 \text{ kJ / kg}$$

1 kg suvni 5 MPa doimiy bosimda $t_1 = 120\text{ }^\circ\text{C}$ suvdan $t_2 = 440\text{ }^\circ\text{C}$ ga ega bo'lgan ortiqcha qizigan bug'ga aylantirishga sarflanadigan issiqlik miqdori:

$$q_{1,2} = i_2 - i_1 = 3293,6 - 507,2 = 2786,1 \text{ kJ / kg.}$$

$P = 5 \cdot 10^6$ Pa bosimda:

qaynayotgan suyuqlik entalpiyasi $i' = 1154,4 \text{ kJ / kg}$;

bug' hosil bo'lishining solishtirma issiqligi $p = 1639,7 \text{ kJ / kg}$;

entalpiya to'yingan quruq bug'ning $i'' = 2794,2 \text{ kJ / kg}$.

Quyidagilarga sarflanadigan issiqlik miqdori:

– suvni qaynashga qadar isitishga

$$q_v = i' - i_1 = 1154,5 - 507,2 = 653,3 \text{ kJ / kg};$$

– bug' hosil bo'lish jarayoniga

$$r = i'' - i' = 2794,2 - 1154,5 = 1639,7 \text{ kJ/kg};$$

– bug'ni qizdirishga

$$q_{\text{per}} = i_2 - i'' = 3293,3 - 2794,2 = 499,1 \text{ kJ / kg.}$$

Bug'ning ortiqcha qizish darajasiga

$$\Delta t = t_2 - t_n = 440 - 263,94 = 176,06\text{ }^\circ\text{C.}$$

Hajmning o'zgarish ishiga

$$\ell = p \cdot (v_2 - v_1) = 5 \cdot 10^3 \cdot (0,06225 - 0,0010588) = 306 \text{ kJ / kg.}$$

Javob: $q_{1,2} = 2786,1 \text{ kJ / kg}$; $q_{\text{per}} = 499,1 \text{ kJ / kg}$;

$q_v = 653,3 \text{ kJ / kg}$; $\Delta t = 176,06\text{ }^\circ\text{C}$;

$r = 1639,7 \text{ kJ / kg}$; $\ell = 306 \text{ kJ / kg}$.

1.34-masala. Bosimi 700 kPa va quruqlik darajasi 0,75 bo'lgan 1 m suv bug'ining massasi aniqlansin.

Javob: $m = 4,9 \text{ kg}$.

1.35-masala. To'yingan quruq bug'ning 10 bar bosimdagi ichki energiyasi aniqlansin.

Javob: $i = 2582,7 \text{ kJ / kg}$.

1.36-masala. Sig‘imi 5 m^3 bo‘lgan idishda bosimi 150 bar va quruqlik darajasi $0,3$ bo‘lgan to‘yingan nam bug‘ bor. Nam bug‘ massasi va qaynayotgan suv va to‘yingan quruq bug‘ egallagan hajm aniqlansin.

Javob: $m = 1,17\text{ t}$; $v' = 1,36\text{ m}^3$; $v'' = 3,64\text{ m}^3$.

1.37-masala. Boshlang‘ich parametrlari $p_1 = 60\text{ bar}$ va $t_1 = 430\text{ }^\circ\text{C}$ bo‘lgan $0,2\text{ m}^3$ suv bug‘i izobarali tarzda shunday siqiladiki, uning hajmi 5 marta kamayadi. Ketkazilgan issiqlik miqdori aniqlansin. Jarayon p, v -, T, s - va i, s - diagrammalarda tasvirlansin.

Javob: $Q = -6,36\text{ MJ}$.

1.38-masala. 500 kPa bosimda va quruqlik darajasi $0,75$ bo‘lganida 2 kg suv bug‘i izotermik ravishda 100 kPa bosimga qadar kengayadi. Keltirilgan issiqlik miqdori aniqlansin.

Javob: $Q = 1,7\text{ MJ}$.

1.39-masala. Doimiy harorat $300\text{ }^\circ\text{C}$ bo‘lganida 1 kg to‘yingan quruq bug‘dan 165 kJ issiqlik olib ketiladi. Jarayon tugashidagi entalpiya qiymati aniqlansin.

Javob: $i = 2583,4\text{ kJ / kg}$.

1.40-masala. 1 kg suv doimiy bosim 1 MPa va boshlang‘ich harorat $100\text{ }^\circ\text{C}$ bo‘lganida 2100 kJ / kg issiqlik olib, so‘ng adiabatli tarzda $0,1\text{ MPa}$ bosimga qadar kengayadi. Jarayonlar hisoblanib, p, v -, T, s - va i, s - diagrammalarda tasvirlansin.

Javob: $l_{1-2} = 167,96\text{ kJ / kg}$; $l_{2-3} = 308,22\text{ kJ / kg}$;
 $q_{1-2} = 2100\text{ kJ / kg}$; $q_{2-3} = 0\text{ kJ / kg}$;
 $\Delta u_{1-2} = 1932,04\text{ kJ / kg}$; $\Delta u_{2-3} = -308,22\text{ kJ / kg}$.

1.41-masala. $t_1 = 350\text{ }^\circ\text{C}$ va $p_1 = 8\text{ bar}$ bo‘lgan suv bug‘i doimiy hajmda sovutiladi. Chekli holatda $i_2 = 2400\text{ kJ / kg}$. Jarayon hisoblanib, p, v -, T, s - va i, s - diagrammalarda tasvirlansin.

Javob: $q = \Delta u = -632,2\text{ kJ / kg}$; $\ell = 0$;
 $\Delta s = -1,35\text{ kJ / (kg} \cdot \text{ }^\circ\text{K)}$; $\Delta i = -760\text{ kJ / kg}$.

1.5. Nam havo

Nam havo quruq havo va suv bug‘ining aralashmasidan iborat.

Nam havo nam havodagi suv bug‘ining fazaviy holatiga bog‘liq holda to‘yingan, to‘yinmagan va o‘ta to‘yingan bo‘lishi mumkin.

To‘yinmagan nam havo deb quruq havo va ortiqcha qizdirilgan suv bug‘ining aralashmasiga aytiladi.

To'yingan nam havo deb quruq havo va quruq to'yingan bug' aralashmasiga aytiladi.

O'ta to'yingan nam havo deb quruq havo va to'yingan nam suv bug'ining aralashmasiga aytiladi.

Nam havo holati nam havodagi suv bug'ining parsial bosimi kattaligiga ko'ra aniqlanadi.

Suv bug'ining nam havodagi parsial bosimi kichik, shu sababli bug'ga, ayniqsa, ortiqcha qizigan bug'ga nisbatan ideal gazlar qonunlari qo'llanishi mumkin.

Dalton qonuniga binoan, nam havo p bosimi quruq havo va suv bug'ining parsial bosimlari yig'indisiga teng:

$$p = p_{\text{havo}} + p_b, \quad (1.58)$$

bu yerda p_{havo} – quruq havoning parsial bosimi;

p_b – suv bug'ining parsial bosimi.

Nam havoning asosiy tavsiflari:

– havoning mutlaq namligi (ρ) - 1 m³ nam havodagi bug'ning massa miqdori;

– havoning nisbiy namligi (φ) – havo mutlaq namligining mumkin bo'lgan maksimal nam havo haroratiga nisbati:

$$\varphi = \frac{\rho}{\rho_{\text{max}}} = \frac{\rho}{\rho''} = \frac{p_b}{p_n} \quad (1.59)$$

bu yerda ρ'' – nam havo haroratida quruq to'yingan bug'ning zichligi;

p_b – nam havo haroratida to'yingan suv bug'ining parsial bosimi;

shudring nuqtasi harorati – bug'ning parsial bosimida to'yinish holatiga erishiladigan harorat.

Nam havoning nam saqlami deb, nam havo tarkibidagi bug' massasining quruq havo massasining nisbatiga aytiladi:

$$d = \frac{m_b}{m_x} = \frac{p_b}{\rho_x} \quad (1.60)$$

Nam saqlami (d) g/kg da hisoblanadi. Nam saqlami quyidagicha aniqlanadi:

$$d = 0,622 \cdot \frac{p_b}{p - p_b} = 0,622 \cdot \frac{p_b}{p_{\text{havo}}}, \frac{g}{kg \text{ g-h}} \quad (1.61)$$

– nam havo entalpiyasi (I) 1 kg quruq havoga nisbatan aniqlanib, 1 kg quruq havodagi mavjud komponentlar entalpiyasi yig‘indisidan iborat:

$$I = c_p \cdot t + d \cdot i_b, \text{ kJ / kg g.h.}, \quad (1.62)$$

bu yerda c_p – havoning izobarali massaviy issiqlik sig‘imi (kJ / kg ·°K),

t – havo harorati, °C,

d – tarkibdagi namlik miqdori, g / kg g.h.,

i_b – suv bug‘ining entalpiyasi, kJ / kg.

Nam havoning holatini tavsiflab keladigan kattaliklarni aniqlash uchun, suv va suv bug‘ining termodinamik xossalarining jadvallari va nam havoning I, d - diagrammalari qo‘llanadi.

Nam havoning I, d - diagrammasi 1.9-rasmda taqdim etilgan.

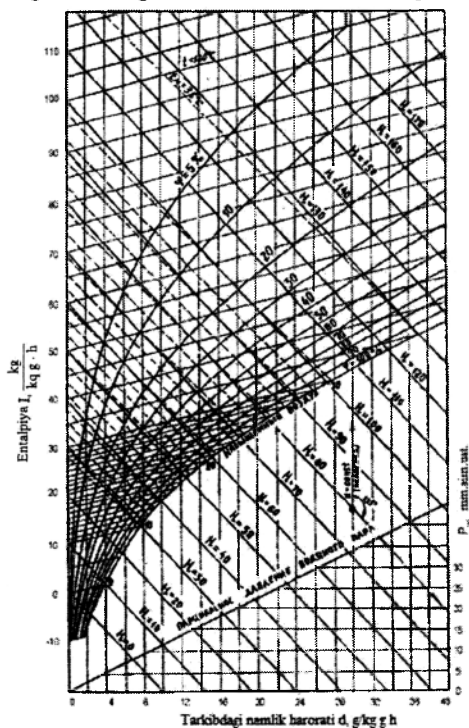

1.9-rasm. R = 745 mm. sim. ust. bo‘lganida nam atmosfera havosining I, d - diagrammasi

Diagramma qiya burchakli koordinatalar tizimida quriladi. Tarkibdagi namlik miqdori $o'qi$ (d) va entalpiyalar (I) orasidagi burchak 135° ni tashkil etadi.

Havoning nisbiy namlik chizig'i $\varphi = 100\%$ diagrammani 2 sohaga bo'lib turadi: chiziqdan yuqorida – to'yinmagan nam havo holati, chiziqdan pastda - o'ta to'yingan nam havo holati.

$\varphi = 100\%$ egri chizig'i to'yingan nam havoga to'g'ri keladi.

I, d - diagrammadagi izotermalar to'g'ri chiziqlardan iborat. Harorat ortishi bilan izotermalarning yotqlik burchagi ham kattalashib boradi.

Diagrammada nam termometr izotermalari uzuq chiziq ko'rinishida tushirilgan. $\varphi = 100\%$ bo'lganida nam va quruq termometrlar haroratlari o'zaro teng $t_n = t_{g,h}$.

Diagrammaning quyi qismida koordinatalarning to'g'riburchakli tizimida suv bug'i parsial bosimining havodagi namlik miqdoriga bog'liqligini tavsiflab keladigan chiziq berilgan.

1.42-masala. Nam havo $50^\circ C$ haroratda joylashgan. Barometrdagi bosim $p = 745$ mm sim. ust. bo'lganida nam havodagi suv bug'ining parsial bosimi $37,5$ mm sim. ust. Nam havo holati, shudring nuqtasi harorati, havoning mutlaq namligi, havoning nisbiy namligi, nam havo tarkibidagi namlik miqdori va uning entalpiyasi aniqlansin.

Yechim: Masalaning suv va suv bug'ining issiqlik-fizik xossalari jadvallaridan foydalangan holdagi yechilishini ko'rib chiqamiz [8,14].

Nam havo holati bug'ning parsial bosimiga $p_b = 37,5$ mm sim. ust. To'yinish harorati to'g'ri keladi $t_n = 32,88^\circ C$ [8, 2-jadv.].

Masala shartiga ko'ra nam havodagi suv bug'i harorati $t = 50^\circ C$, ya'ni to'yinish haroratidan baland, demak bug' o'ta qizigan bo'ladi.

Quruq havoning ortiqcha qizigan suv bug'i bilan aralashmasi to'yinmagan nam havo deb nomlanadi.

Shunday qilib, $p_b = 37,5$ mm sim. ust. va $t = 50^\circ C$ bo'lganida nam havo to'yinmagan.

Shudring nuqtasi harorati

Suv bug'ining parsial bosimida uning to'yinish harorati $32,88^\circ C$ ga teng.

$$t_b = 32,88^\circ C.$$

Havoning mutlaq namligi

$$\rho = \frac{1}{v}$$

bu yerda v – bug‘ning solishtirma hajmi.

$p_b = 37,5$ mm sim. ust. bo‘lganida $p_b = 0,05$ bar va $t = 50$ °C [8, 3-jadv.]

$$v = 29,78 \text{ m}^3 / \text{kg},$$

$$\rho = \frac{1}{v} = \frac{1}{29,78} = 0,0336 \frac{\text{kg}}{\text{m}^3}.$$

Havoning nisbiy namligi

$$\varphi = \frac{\rho}{\rho''} = \frac{p_b}{p_n}$$

$t = 50$ °C bo‘lganida [8, 1-jadv.]:

$$v'' = 12,028 \text{ m}^3 / \text{kg}; p_n = 0,1235 \text{ bar}.$$

$$\rho'' = \frac{1}{v''} = \frac{1}{12,028} = 0,083 \frac{\text{kg}}{\text{m}^3}.$$

$$\varphi = \frac{\rho}{\rho''} = \frac{0,0336}{0,083} = 0,4048 = 40,48\%.$$

$$\varphi = \frac{p_b}{p_n} = \frac{0,05}{0,1235} = 0,4048 = 40,48\%$$

1 kg quruq havodagi olingan namlik miqdori

$$d = \frac{622 \cdot p_b}{(p - p_b)} = \frac{622 \cdot 37,5}{745 - 37,5} = 32,97 \frac{\text{g}}{\text{kg}}$$

1 kg quruq havodagi nam havo entalpiyasi

$$I = c_p \cdot t + d \cdot i_{pb}; c_p = 1 \text{ kJ} / (\text{kg} \cdot \text{°K}).$$

$p_b = 0,05$ bar va $t = 50$ °C [8, 3-jadv.] bo‘lganida;

$i_b = 2593,4$ kJ / kg;

$$I = 50 + 32,97 \cdot 10^{-3} \cdot 2593,4 = 135,5 \text{ kJ} / \text{kg g.h.}$$

Masalani nam havoning I,d – diagrammasidan foydalanib yechilishini ko‘rib chiqamiz (1.10-rasm).

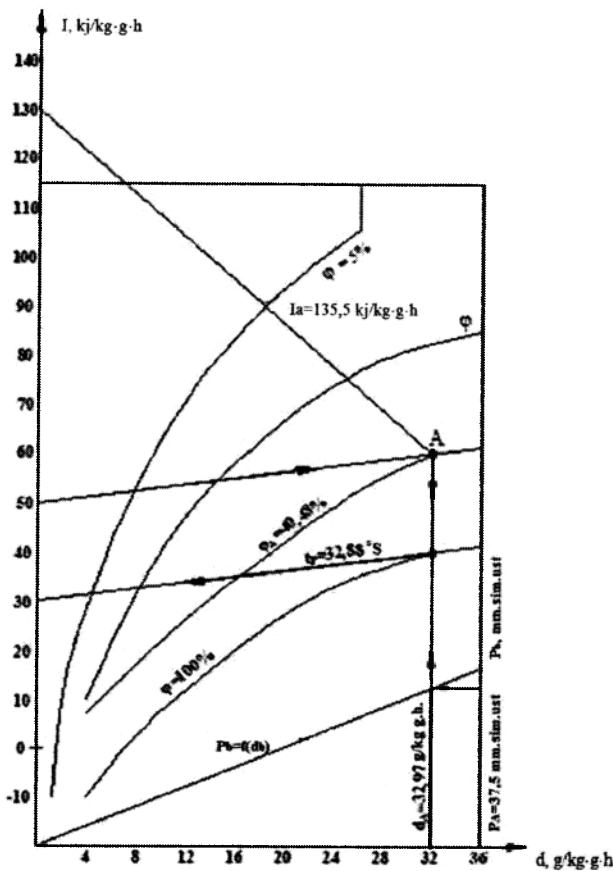

1.10-rasm. Nam havo parametrlarini I,d - diagramma bo‘yicha aniqlash

10-rasmda strelkalar bilan I,d - diagramma bo‘yicha berilgan parametrlari A nuqtani aniqlash yo‘li ko‘rsatilgan: $p_b = 37,5$ mm sim. ust. bo‘lganida chiziqdan parsial bosimlar chizig‘idan 50 °C izotermasi bilan kesishishga qadar vertikal chiziq o‘tkazamiz.

Nam havo holati

A nuqta nisbiy namlik egri chizig'idan $\varphi = 100\%$ yuqoriroq joylashgan. Demak, nam havo - to'yinmagan.

Shudring nuqtasi harorati

Shudring nuqtasi haroratining qiymati A nuqtadan $\varphi = 100\%$ chiziqqa tushirilgan vertikalni kesib o'tishda izoterma bo'yicha aniqlanadi.

$$t_r = 32,88 \text{ }^\circ\text{C}.$$

Havoning mutlaq namligi

Havoning mutlaq namligi I,d - diagramma bo'yicha aniqlanmaydi.

Havoning nisbiy namligi

A nuqta $\varphi = 40\%$ va $\varphi = 50\%$ egri chiziqlari orasida joylashgan. Grafik interpolyatsiya havoning nisbiy namligi qiymatini beradi $\varphi_A = 40,48\%$.

1 kg quruq havodagi namlik miqdori

Namlik miqdori ushbu nuqtada absissalar o'qi bo'yicha aniqlanadi $d_A = 32,97 \text{ g / kg g.h.}$

1 kg quruq havodagi nam havo entalpiyasi

Nam havo entalpiyasi qiymati ordinatalar o'qi bo'yicha aniqlanadi. A nuqta $I = 130 \text{ kJ / kg g.h.}$ va $I = 140 \text{ kJ / kg g.h.}$ chiziqlari orasida joylashadi. Grafik interpolyatsiya $I_A = 135,5 \text{ kJ / kg g.h.}$ qiymatini beradi.

1.43-masala. Agar psixrometr bo'yicha quruq va nam termometrlar haroratlari teng, ya'ni $t_s = 40 \text{ }^\circ\text{C}$, $t_m = 30 \text{ }^\circ\text{C}$ bo'lsa, havoning holati, uning nisbiy namligi, namlik miqdori, nam havo entalpiyasi, shuningdek nam havodagi suv bug'larining parsial bosimi aniqlansin. Barometrik bosim $p = 745 \text{ mm sim. ust.}$

Yechim: I,d – diagramma bo'yicha bizga berilgan nam havo holatini aniqlaymiz (1.11-rasm).

izotermasining (uzuq chiziq) quruq termometr $t_s = 40\text{ }^\circ\text{C}$ izotermasi bilan kesishish nuqtasini topamiz. Olingan V nuqta nam havo holatini aniqlab beradi.

V nuqtasi holati bo'yicha (1.42-masaladagi kabi):

nam havo holati - to'yinmagan nam havo;

$$\varphi_v = 40\ %;$$

$$d_v = 13,7\ \text{g} / \text{kg g.h.};$$

$$I_v = 81,76\ \text{kJ} / \text{kg g.h.}$$

Diagramma o'ng qismi ordinatalar o'qi bo'yicha, dastlab V nuqtadan parsial bosimlar chizig'iga qadar vertikal tushirib, suv bug'i parsial bosimi qiymatini topamiz.

$$p_b = 13,21\ \text{mm sim. ust.}$$

1.44-masala. Nam havo barometrik bosim $p = 745\ \text{mm sim. ust.}$ bo'lganida $50\text{ }^\circ\text{C}$ haroratga ega. Nam havodagi suv bug'ining parsial bosimi $45\ \text{mm sim. ust.}$ ni tashkil qiladi. Nam havoning mutlaq va nisbiy namligi, namlik miqdori va entalpiyasi aniqlansin.

Suv va suv bug'ining issiqlik - fizik xossalari jadvallari va nam havoning I,d - diagrammasidan foydalanib masalani yeching.

Javob: $\rho = 0,04\ \text{kg} / \text{m}^3$; $\varphi = 48,6\ %$; $d = 40\ \text{g} / \text{kg g.h.};$

$$I = 153,73\ \text{kJ} / \text{kg.}$$

1.45-masala. $40\text{ }^\circ\text{C}$ haroratdagi mavjud nam havoning nisbiy namligi $50\ %$ ga teng. Nam havodagi suv bug'larining namlik miqdori nam saqlash, entalpiyasi, shudring nuqtasi harorati va parsial bosimi aniqlansin. Barometrik bosim $750\ \text{mm sim. ust.}$

Javob: $d = 23,9\ \text{g} / \text{kg g.h.};$ $I = 101,5\ \text{kJ} / \text{kg};$

$$p_b = 27,75\ \text{mm sim. ust.}; \quad t_r = 27,7\text{ }^\circ\text{C.}$$

1.46-masala. Agar nam havo harorati $25\text{ }^\circ\text{C}$, shudring nuqtasi harorati esa $17,5\text{ }^\circ\text{C}$ bo'lsa, havoning nisbiy namligi, entalpiyasi, havodagi namlik miqdori va nam havodagi suv bug'ining parsial bosimi aniqlansin. Barometrik bosim $p = 750\ \text{mm sim. ust.}$

Javob: $\varphi = 63,1\ %$; $d = 12,72\ \text{g} / \text{kg g.h.};$

$$I = 57,4\ \text{kJ} / \text{kg};$$

$$p_b = 1,9986\ \text{kPa.}$$

1.47-masala. Nam havoning holatini aniqlash uchun quruq termometri $40\text{ }^{\circ}\text{C}$ ni, nam termometri esa $-30\text{ }^{\circ}\text{C}$ ni ko'rsatayotgan psixrometr qo'llanadi. Nam havoning I,d - diagrammasidan foydalanib havoning mutlaq va nisbiy namligi, entalpiyasi, havodagi namlik miqdori, shudring nuqtasi va nam havodagi suv bug'larining parsial bosimi aniqlansin.

Javob: $\varphi = 50\%$; $d = 23\text{ g/kg g.h.}$;
 $I = 102\text{ kJ/kg}$; $p_b = 26\text{ mm sim. ust.}$;
 $t_r = 27,3\text{ }^{\circ}\text{C}$.

1.48-masala. Nam havoning shudring nuqtasi harorati gigrometr bo'yicha aniqlangan bo'lib, $25\text{ }^{\circ}\text{C}$ ni tashkil qiladi. Nam havo $40\text{ }^{\circ}\text{C}$ haroratga ega. Havoning mutlaq va nisbiy namligi, undagi namlik miqdori, entalpiyasi va nam havodagi suv bug'ining parsial bosimi aniqlansin. Barometrik bosim $p = 745\text{ mm sim. ust}$.

Javob: $\rho = 0,0221\text{ kg/m}^3$; $\varphi = 43,39\%$;
 $d = 20,71\text{ g/kg g.h.}$;
 $I = 93,33\text{ kJ/kg}$; $p_b = 3,2\text{ kPa}$.

1.6. Bug'-kuch uskunasi (BKU) sikli.

Bug'ni qizdirish bilan kechadigan Renkin sikli

Bug'-kuch uskunasi (BKU) ishchi jism holatini o'zgartirish bo'yicha yopiq jarayon sodir etadi. BKU ideal sikli ikkita izobara va ikkita adiabatadan iborat. Ishchi jism quyi bosim sohasidan yuqori bosim sohasiga minimal solishtirma hajmda suyuqlik holatida o'tkaziladi. Issiqlik haydab keltirish va ketkazish jarayonlari $p = \text{const}$ da yuz beradilar. Turbinadagi kengayish va nasosdagi bosim ko'tarilishi jarayonlari tez yuz bergani sababli ularni adiabatil deb hisoblash mumkin. Siklning minimal harorati kondensatordagi sovituvchi suvning haroratiga teng bo'lib, maksimal harorat esa po'latning issiqqa chidamliligi va mexanik mustahkamligi bilan cheklanadi.

Bug'-kuch uskunasi (BKU) prinsipl sxemasi (BKU) 1.12-rasmda, p , v -, T , s -, va i , s - diagrammalardagi Renkin sikli esa 1.13-rasmda tasvirlangan. Diagrammalardagi nuqtalar bug'-kuch uskunasi sxemasidagi nuqtalarga muvofiq keladi.

Sikl quyidagi tarzda ro'y beradi. p_0 bosimli va $i_A = c \cdot t_{pu}$ (A.n.) entalpiyasi ta'minot suvi bug' qozoniga kelib tushib, bu yerda u qozonning suv

ekonomayzerida to‘yinish haroratiga t_n (B n.) qadar qizdirilib, so‘ng quruq to‘yingan suv bug‘iga (V n.) aylanadi va bug‘ni ortiqcha qizdirgichida t_0 ga qadar ortiqcha qizdiriladi (G n.). Issiqlikni ABVG ishchi jismiga keltirish jarayoni $p_0 = \text{const}$ doimiy bosimda yuz beradi.

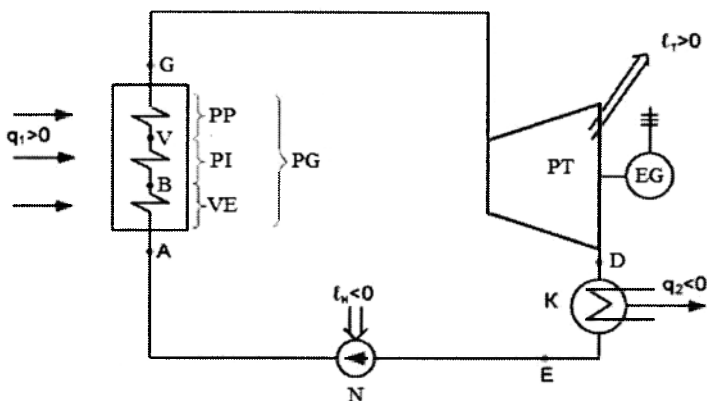

1.12-rasm. Bug‘-kuch uskunasiining prinsipial sxemasi:

VE – suv ekonomayzeri; PI – bug‘lanish yuzasi;

PP – bug‘ qayta isitgich; PG – bug‘ generatori; PT – bug‘ turbinasi;

K – kondensator; N – nasos; EG – elektr generator

G nuqtasidagi bug‘ parametrlari bug‘ qizdirgichdan so‘ng p_0 , t_0 , i_0 qiymatlarga ega bo‘ladilar. Bug‘ qizdirgichdan bug‘ turbinaga kelib tushib, unda adiabat jarayonida kondensatordagi bosim r_k ga qadar kengayadi - GD jarayoni. D. nuqtadagi bug‘ parametrlari turbinadan so‘ng p_k , t_k , i_k qiymatlariga ega bo‘ladilar. Turbina ishi ℓ_1 elektrogeneratorda elektr ishga aylanib, iste‘molchilarga uzatiladi.

Kondensatorda bug‘ issiqlik q_2 ning sovutgichga o‘tishi hisobiga kondensatsiyalanadi. Bug‘ning kondensatorda kondensatsiyalanish jarayoni DE doimiy bosim p_k va doimi harorat t_k da ro‘y beradi.

Tomchili suyuqlik (kondensat) kondensatordan so‘ng minimal hajm v'_k bilan nasos yordamida bug‘ qozoniga uzatilib, bunda ishchi jism bosimi p_k dan p_0 gacha o‘zgaradi. Ta‘minot suvi EA ning gacha adiabatali siqilish jarayoni bir vaqtning o‘zida suvning kam siqiluvchanlik xususiyati tufayli izoxorali bo‘lib ham hisoblanadi.

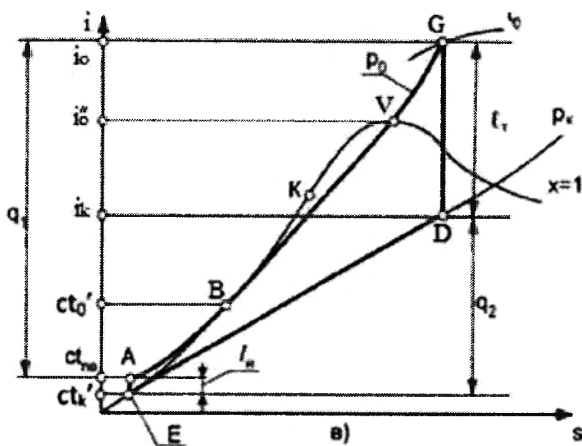
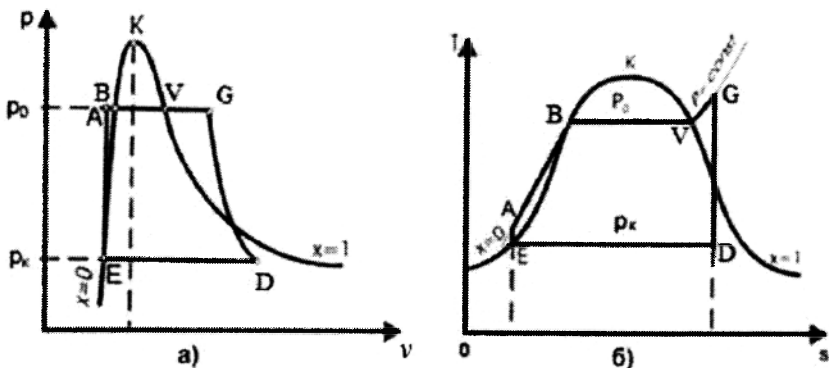

1.13-rasm. Bug'ni ortiqcha qizitish bilan kechadigan Renkin sikli

Muhandislik hisob-kitoblarda BKU siklining asosiy ko'rsatkichlarini i, s - diagrammadan foydalanib hisoblash (aniqlash) qulay. I, s - diagrammadan (1.13, b-rasm) foydalanib quyidagilarni osonlik bilan olish mumkin:

– ishchi jismga keltirilgan issiqlik miqdori

$$q_1 = i_G - i_A = i_0 - ct_{pu}; \quad (1.63)$$

– kondensatordagi issiqlik chiqindisi (teplovoy otbros)

$$q_2 = i_D - i_E = i_k - ct_k; \quad (1.64)$$

– turbinadagi ish

$$\ell_t = i_g - i_d = i_o - i_k; \quad (1.65)$$

– nasosning ish

$$\ell_n = i_A - i_E = ct_{pv} - ct_k = v'_k (p_o - p_k). \quad (1.66)$$

q_1 , ℓ_t va ℓ_n lar uchun ifodalarni hisobga olib, siklning termik f.i.k. ini hisob - kitob qilish formulasi quyidagi ko'rinishga ega:

$$\eta_t = \frac{\ell_t - \ell_n}{q_1} = \frac{i_o - i_k - v'_k (p_o - p_k)}{i_o - i'_k}. \quad (1.67)$$

Turbinadagi ish ℓ_t va siklning termik f.i.k. ini η_t lardan tashqari Renkin sikli samaradorligini tavsiflab keladigan ko'rsatkichlarga bug'ning solishtirma sarfi d_t va 1 kVt·s = 3600 kJ ishlab chiqish uchun zarur bo'lgan turbinaning elektr ishi issiqlikning solishtirma sarfi q_1 oid deb hisoblaydilar. Bug'ning solishtirma sarfi

$$d_t = \frac{1}{l_t}, \frac{kJ}{kg} \quad (1.68)$$

yoki 1 kJ = 1/3600 kVt·s nisbatini hisobga olib

$$d_t = \frac{3600}{l_t} = \frac{3600}{i_o - i_k}, \frac{kJ}{kVt \cdot s} \quad (1.69)$$

Solishtirma issiqlik sarfi formula bo'yicha hisoblab topiladi

$$d_t = \frac{q_1}{l_t} = q_1 \cdot d_t = \frac{1}{\eta''_t}, \frac{kJ_{\text{issiqlik}}}{kJ_{\text{elektr ishi}}}, \quad (1.70)$$

yoki 1 kJ = 1/3600 kVt·s nisbatini hisobga olib

$$q_t = \frac{3600 \cdot q_1}{l_t} = \frac{3600}{\eta''_t}, \frac{kJ}{kVt \cdot s}, \quad (1.71)$$

bu yerda η''_t - termik f.i.k. ini, nasos ishini hisobga olmaganda.

1.49-masala. BKU oddiy sikli quyidagi parametrlarga ega: turbina oddidagi bug' bosimi va harorati $p_o = 150$ bar va $t_o = 530$ °C, kondensatordagi bug' bosimi $p_k = 0,045$ bar. Siklning termik f.i.k. ini, bug' va issiqlik ishlab chiqilgan kVt·s ga solishtirma sarflari aniqlansin.

Yechim: p_0 va t_0 qiymatlari bo'yicha [14; 3-jadv.] bug'ning qozondan chiqishdagi entalpiyasi va entropiyasini aniqlaymiz: $i_0 = 3395,7 \text{ kJ / kg}$; $s_0 = 6,4556 \text{ kJ / (kg} \cdot \text{°K)}$.

Nasosdagi ta'minot suvining adiabatali siqilish jarayoni bir vaqtning o'zida izoxorali bo'lib keladi (1.14-rasm).

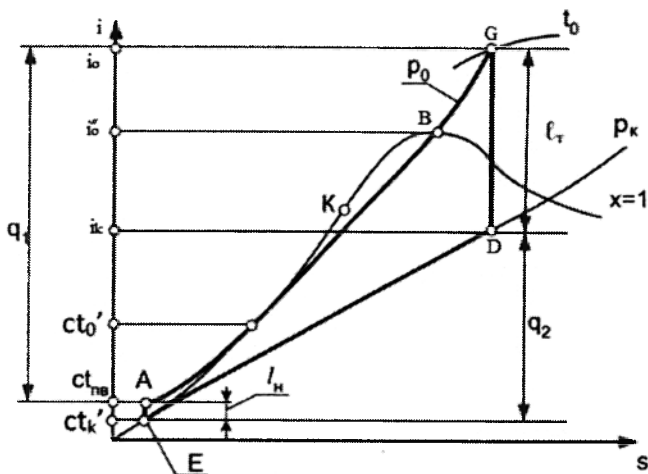

1.14-rasm. I, s - diagrammaga BKU sikli

Nasosdagi suvning siqilish ishi

$$l_n = i_A - i_E = ct_{pv} - ct'_k = v'_k (p_0 - p_k),$$

bu yerda ct_{pv} - ta'minot suvining nasosda siqilganidan keyingi entalpiyasi;

$ct'_k - p_k$ bosimda to'yingan holatdagi suv entalpiyasi $ct'_k = 129,98 \text{ kJ / kg}$ [8,14; 2-jadv.].

$$l_n = v'_k (p_0 - p_k) \cdot 100 = 0,0010047 \cdot (150 - 0,045) \cdot 100 = 15,066 \text{ kJ / kg};$$

$$ct_{pv} = ct'_k + l_n = 129,98 + 15,066 = 145,046 \text{ kJ/kg}.$$

$P_0 = 150 \text{ bar} = 15 \cdot 10^6 \text{ Pa}$ bosimda [14; 2-jadv.]:

- qaynayotgan suyuqlik entalpiyasi $ct'_0 = 1610,2 \text{ kJ / kg}$;
- bug' hosil bo'lishining solishtirma issiqligi $r = 1000,7 \text{ kJ / kg}$;
- to'yingan quruq bug'ning entalpiyasi $i''_0 = 2610,9 \text{ kJ / kg}$.

Quyidagilarga sarflanadigan issiqlik miqdori:

– suvni qaynashga qadar isitishga

$$q_v = i_B - i_A = ct'_0 - ct_{pv} = 1610,2 - 145,046 = 1465,15 \text{ kJ / kg};$$

– bug‘ hosil bo‘lish jarayoniga

$$r = i_v - i_B = i''_0 - ct'_0 = 2610,9 - 1610,2 = 1000,7 \text{ kJ / kg};$$

– bug‘ni o‘ta qizdirishga

$$q_{per} = i_G - i_v = i_0 - i''_0 = 3395,74 - 2610,9 = 784,8 \text{ kJ / kg}.$$

Ishchi jismiga keltirilgan issiqlik miqdori

$$q_1 = i_G - i_A = i_0 - ct_{pv} = 3395,7 - 145,046 = 3250,65 \text{ kJ / kg}.$$

Kondensatordagi bug‘ bosimi $p_k = 0,045 \text{ bar} = 4,5 \cdot 10^3 \text{ Pa}$ bo‘lganida [14; 2-jadv.]:

– to‘yingan holatdagi suv entalpiyasi

$$ct'_0 = 129,98 \text{ kJ / kg};$$

– to‘yingan holatdagi suv entropiyasi

$$s'_k = 0,4507 \text{ kJ / (kg} \cdot \text{°K)};$$

– to‘yingan holatdagi suv bug‘ining entalpiyasi

$$i''_0 = 2557,4 \text{ kJ / kg};$$

– suv bug‘ining to‘yingan holatdagi entropiyasi

$$s''_k = 8,4314 \text{ kJ / (kg} \cdot \text{°K)}.$$

P_k va $s_k = s_0$ bo‘lganida turbinadan chiqishdagi bug‘ parametrlari:

– bug‘ning quruqlik darajasi

$$x_k = \frac{s_k - s'}{s'' - s'} = \frac{6,4556 - 0,4507}{8,4314 - 0,4507} = 0,7516$$

– bug‘ entalpiyasi

$$i_k = ct'_k + x_k (i''_k - ct'_k) = 129,98 + 0,7516 (2557,4 - 129,98) = 1954,43 \text{ kJ / kg}.$$

Bug'ning turbinadagi adiabatli kengayishining texnik ishi

$$\ell_t = i_G - i_D = i_0 - i_k = 3395,7 - 1954,43 = 1441,27 \text{ kJ / kg.}$$

Kondensatordagi ishchi jismdan haydalgan issiqlik

$$q_2 = i_D - i_E = i_k - ct'_k = 1954,43 - 129,98 = 1824,45 \text{ kJ / kg.}$$

Siklning termik f.i.k. ini

$$\eta_l = \frac{l_t - l_n}{q_l} = \frac{1441,27 - 15,066}{3250,65} = 0,4387$$

Turbina tomonidan amalga oshirilgan 1 kVt·s ish hisobiga bug'ning solishtirma sarfi:

$$d_t = \frac{3600}{l_t} = \frac{3600}{1441,27} = 2,4978, \frac{\text{kg}}{\text{kVt} \cdot \text{s}}$$

Turbina tomonidan amalga oshirilgan 1 kVt·s ish hisobiga issiqlikning solishtirma sarfi

$$q_l = \frac{3600}{l_t} = \frac{3600 \cdot 3250,65}{1441,27} = 8119,464, \frac{\text{kJ}}{\text{kVt} \cdot \text{s}}$$

Javob: $\eta_t = 43,87 \%$; $d_t = 2,4978 \text{ kg / (kVt} \cdot \text{s)}$; $q_l = 8119,464 \text{ kJ / (kVt} \cdot \text{s)}$

1.50-masala. Oddiy BKU sikli quyidagi parametrlarga ega: turbinada oldidagi bug' bosimi va bug' harorati $p_0 = 110 \text{ bar}$, $t_0 = 490 \text{ }^\circ\text{C}$, kondensatordagi bug' bosimi $p_k = 0,05 \text{ bar}$. Siklning termik f.i.k. ini aniqlansin.

Javob: $\eta_t = 42,074 \%$.

1.51-masala. Agar 1-masala shartlarida kondensatordagi bug' bosimi 120 bar ($p_0 = 120 \text{ bar}$) gacha, masala shartlarida turbinada oldidagi 1 bug' bosimi 120 bar ($p_0 = 120 \text{ bar}$) gacha ko'tarilib, barcha qolgan shartlar o'zgarishsiz qolsa, siklning termik FIKi qanchaga o'zgarishi aniqlansin.

Javob: $\eta_t = 42,329 \%$ (0,255 % ga kattalashadi).

1.52-masala. Agar 1-masala shartlarida bug'ning turbinada oldidagi harorati $520 \text{ }^\circ\text{C}$ ($t_0 = 520 \text{ }^\circ\text{C}$) deb olinsa, siklning termik FIK ini qanchaga o'zgarishi aniqlansin, barcha qolgan shartlar o'zgarishsiz qoladi.

Javob: $\eta_t = 44,16 \%$ (2,09 % ga kattalashadi).

1.53-masala. Agar 1-masala shartlarida kondensatordagi bug' bosimi 0,03 bar ($p_k = 0,03 \text{ bar}$) deb olinsa, siklning termik f.i.k. ini qanchaga o'zgarishi aniqlansin, barcha qolgan shartlar o'zgarishsiz qoladi.

Javob: $\eta_t = 43,258 \%$ (1,184 % ga kattalashadi).

2-BOB. ISSIQLIK VA MASSA ALMASHINUV ASOSLARI

2.1. Statsionar issiqlik uzatish jarayoni

Yassi devor orqali issiqlik uzatish

Yassi devor orqali issiqlik uzatilish hisob - kitobini issiqlik oqimining yuza zichligini qoʻllagan holda bajarish qulay:

$$q = \frac{Q}{F}, \quad (2.1)$$

bu yerda Q – issiqlik oqimi, Vt ;

F – devor maydoni, m^2 .

Bu holda

$$q = \frac{\Delta T}{R_t}, \quad (2.2)$$

bu yerda ΔT – issiqlik almashinuvining berilgan uchastkasida harorat farqi (koʻtarilib tushishi), $^{\circ}K$ ($^{\circ}C$), u issiqlik almashinuvining bitta yoki bir nechta qoʻshni elementar uchastkalaridan tashkil topishi mumkin: issiqlik uzatish va issiqlik oʻtkazuvchanlik;

R_t – ana shu uchastka yoki qoʻshni uchastkalar birligining issiqlik almashinuvi termik qarshiligi, $(m^2 \cdot ^{\circ}K) / Vt$.

Issiqlik uzatishning termik qarshiligi formula boʻyicha hisoblab topiladi:

$$R_{t,a} = \frac{1}{\alpha}, \quad (2.3)$$

bu yerda α – issiqlik berish koeffitsiyenti, $Vt / (m^2 \cdot ^{\circ}K)$.

Yassi devorning i -nchi qatlami orqali issiqlik oʻtkazish termik qarshiligini hisob-kitob qilish uchun formula quyidagi koʻrinishga ega:

$$R_{t,i} = \frac{\delta_i}{\lambda_i}, \quad (2.4)$$

bu yerda δ_i – i -nchi qatlam qalinligi, m;

λ_i – ko‘p qatlamli devor i -nchi qatlamining issiqlik o‘tkazish koeffitsiyenti, $\text{Vt} / (\text{m} \cdot ^\circ\text{K})$.

Issiqlik uzatishning termik qarshiligi barcha issiqlik almashinuv elementar uchastkalarining termik qarshiliklari yig‘indisiga teng.

Tavsiya etilgan yechish ketma-ketligi:

a) barcha elementar uchastkalarining termik qarshiligi aniqlanadi;

b) issiqlik almashinuv tizimida ikkita berilgan harorat bo‘yicha issiqlik oqimining zichligi topiladi;

c) q ning topilgan qiymati va ma‘lum haroratlardan biri bo‘yicha qatlamlar va suyuqliklarning qolgan noma‘lum haroratlari hisoblab topiladi.

Silindrsimon devor orqali issiqlik uzatish

Silindrsimon shakldagi devor orqali issiqlik uzatilishini hisob-kitob qilish uchun issiqlik oqimining chiziqli zichligi deb ataladigan solishtirma issiqlik oqimidan foydalanadilar:

$$q_t = \frac{Q}{\ell}, \quad (2.5)$$

bu yerda Q - issiqlik oqimi, Vt ;

ℓ - silindrsimon devor uzunligi, m.

$$q_t = \frac{\pi \cdot \Delta T}{R_t}, \quad (2.6)$$

bu yerda ΔT – berilgan issiqlik almashinuv uchastkasida harorat ko‘tarilib – tushishi, $\text{K} (^\circ\text{C})$, issiqlik almashinuvining qator elementar uchastkalaridan tashkil topishi mumkin bo‘lgan: issiqlik berishi va issiqlik o‘tkazuvchanligi;

R_t – ana shu uchastka issiqlik almashinuvining chiziqli termik qarshiligi, $(\text{m} \cdot ^\circ\text{K}) / \text{Vt}$.

Issiqlik uzatishning chiziqli termik qarshiligi formula bo‘yicha hisoblab topiladi:

$$R_{t,\alpha} = \frac{1}{\alpha \cdot d}, \quad (2.7)$$

bu yerda α – issiqlik berish koeffitsiyenti, $\text{Vt} / (\text{m}^2 \cdot ^\circ\text{K})$;

d – silindrsimon devorning yuvilayotgan yuzasi diametri, m.

Silindrsimon devorning i -nchi qatlami issiqlik o'tkazuvchanligining chiziqli termik qarshiligi quyidagi formula bo'yicha hisoblab topiladi:

$$R_{t,i} = \frac{1}{2 \cdot \lambda_i} \cdot \ln \frac{d_{i+1}}{d_i}, \quad (2.8)$$

bu yerda λ_i – silindrsimon devor i -nchi qatlamining issiqlik o'tkazuvchanlik koeffitsiyenti, $\text{Vt} / (\text{m} \cdot ^\circ\text{K})$;

d_i va d_{i+1} – silindrsimon devor i -nchi qatlamining ichki va tashqi diametrlari, m.

Masalani silindrsimon devor orqali issiqlik uzatilishi orqali hal qilishning tavsiya etilgan tartibi yuqorida ko'rib chiqilgan yassi devor uchun yechim algoritmi bilan to'liq mos keladi.

2.1-masala. Agar uning yuzalari haroratlaridagi farq $\Delta T = T_{w2} - T_{w1} = 95 \text{ }^\circ\text{C}$ bo'lganida u orqali issiqlik o'tkazuvchanlik bo'lgan stasionar issiqlik oqimi o'tsa, termik qarshiligi R_t va yassi bir qavatli devor qalinligi δ aniqlansin. Devorning issiqlik o'tkazuvchanlik koeffitsiyenti $\lambda = 4 \text{ Vt} / (\text{m} \cdot ^\circ\text{K})$.

Yechim: Issiqlik oqimining bir qavatli devor orqali yuza zichligi $q = \Delta T / R_t$,

bu yerda $R_t = \delta / \lambda$.

$$R_t = \Delta T / q \text{ va } \delta = \lambda \cdot R_t \text{ larni aniqlaymiz.}$$

Masala vazifasiga ko'ra $q = 5 \text{ kVt} / \text{m}^2 = 5000 \text{ Vt} / \text{m}^2$, shunda

$$R_t = \Delta T / q = 95 / 5000 = 0,019 \text{ (m}^2 \cdot ^\circ\text{K) / Vt,}$$

$$\delta = \lambda \cdot R_t = 4 \cdot 0,019 = 0,076 \text{ m.}$$

Javob: $R_t = 0,019 \text{ (m}^2 \cdot ^\circ\text{K) / Vt}$; $\delta = 0,076 \text{ m}$.

2.2-masala. Issiqlik koeffitsiyenti $\lambda = 3 \text{ Vt} / (\text{m} \cdot ^\circ\text{K})$, qalinligi $\delta = 90 \text{ mm}$ bo'lgan yassi devor yuza zichligi $q = 4 \text{ kVt} / \text{m}^2$ bo'lgan stasionar issiqlik oqimini o'tkazadi. Devor issiqlikni qabul qiladigan yuzasining harorati $T_{d1} = 140 \text{ }^\circ\text{C}$. Devor issiqlik o'tkazuvchanligining termik qarshiligi R_t va issiqlik uzatuvchi (beruvchi) yuza harorati T_{d2} aniqlansin.

Yechim: Issiqlik oqimining yuza zichligi

$$q = \Delta T / R_t = (T_{d1} - T_{d2}) / R_t,$$

bu yerda $R_t = \delta / \lambda = 0,09 / 3 = 0,03 \text{ (m}^2 \cdot \text{°K) / Vt}$.

$T_{d1} - T_{d2} = q \cdot R_t$, bundan kelib chiqib,

$$T_{d2} = T_{d1} - q \cdot R_t = 140 - 4000 \cdot 0,03 = 20 \text{ °C}.$$

Javob: $R_t = 0,03 \text{ (m}^2 \cdot \text{°K) / Vt}$; $T_{d2} = 20 \text{ °C}$.

2.3-masala. Yassi devor qalinliklari $\delta_1 = 120 \text{ mm}$, $\delta_2 = 90 \text{ mm}$ va $\delta_3 = 50 \text{ mm}$ bo'lgan uch qatlamdan iborat, qatlamlarning issiqlik o'tkazish koeffitsiyentlari mos ravishda quyidagilarga teng $\lambda_1 = 4 \text{ Vt / (m} \cdot \text{°K)}$, $\lambda_2 = 9 \text{ Vt / (m} \cdot \text{°K)}$ va $\lambda_3 = 12 \text{ Vt / (m} \cdot \text{°K)}$. Ikkinchi qatlam yuzalarining haroratlari $T_{1-2} = 125 \text{ °C}$ va $T_{2-3} = 50 \text{ °C}$. Tashqi yuzalarning T_{d1} va T_{d2} haroratlari aniqlansin.

Yechim: Uch qatlamli devor issiqlik o'tkazuvchanligining to'liq termik qarshiligi qatlamlarning termik qarshiliklari summasiga teng:

$$R_{t1} = \delta_1 / \lambda_1 = 0,12 / 4 = 0,03 \text{ (m}^2 \cdot \text{°K) / Vt};$$

$$R_{t2} = \delta_2 / \lambda_2 = 0,09 / 9 = 0,01 \text{ (m}^2 \cdot \text{°K) / Vt};$$

$$R_{t3} = \delta_3 / \lambda_3 = 0,06 / 12 = 0,005 \text{ (m}^2 \cdot \text{°K) / Vt}.$$

$$R_t = R_{t1} + R_{t2} + R_{t3} = 0,03 + 0,01 + 0,005 = 0,045 \text{ (m}^2 \cdot \text{°K) / Vt}.$$

Issiqlik almashinuvining statsionar rejimida issiqlik oqimining yuza usti zichligi har bir qatlam uchun doimiy bo'lib, istalgan qatlamning parametrlari orqali ifodalanadi:

$$q = \frac{T_{d1} - T_{1-2}}{R_{t1}} = \frac{T_{1-2} - T_{2-3}}{R_{t2}} = \frac{T_{2-3} - T_{d2}}{R_{t3}}; \text{ Vt / m}^2.$$

$$q = \frac{T_{1-2} - T_{2-3}}{R_{t2}} = \frac{125 - 50}{0,01} = 7500 \text{ Vt / m}^2.$$

Devorlar tashqi yuzalarining izlanayotgan haroratlarini ifodalaymiz:

$$T_{d1} = T_{1-2} + q \cdot R_{t1} = 125 + 7500 \cdot 0,03 = 350 \text{ °C};$$

$$T_{d2} = T_{2-3} - q \cdot R_{t3} = 50 - 7500 \cdot 0,005 = 12,5 \text{ °C}.$$

q kattaligini, shuningdek, devorning umumiy termik qarshiligi orqali ifodalash mumkin:

$$q = \frac{T_{d1} - T_{d2}}{R_{t1} + R_{t2} + R_{t3}} = \frac{T_{d1} - T_{d2}}{R_t}$$

Bu ifodadan hisob-kitoblarning to‘g‘riligini tekshirish uchun foydalanish mumkin

$$q = (350 - 12,5)/0,045 = 7500 \text{ Vt/m}^2.$$

Javob: $T_{d1} = 350 \text{ }^\circ\text{C}$; $T_{d2} = 12,5 \text{ }^\circ\text{C}$.

2.4-masala. Qalinligi $\delta = 90 \text{ mm}$ bo‘lgan, issiqlik o‘tkazuvchanlik koeffitsiyenti $\lambda = 9 \text{ Vt} / (\text{m} \cdot \text{ }^\circ\text{K})$ ga teng yassi, bir qavatli devor issiqlik uzatish jarayonida $T_{d1} = 125 \text{ }^\circ\text{C}$ va $T_{d2} = 50 \text{ }^\circ\text{C}$ haroratlariga ega. Agar issiqlik berish koeffitsiyentlari mos ravishda $\alpha_1 = 40 \text{ Vt} / (\text{m}^2 \cdot \text{ }^\circ\text{K})$ va $\alpha_2 = 250 \text{ Vt} / (\text{m}^2 \cdot \text{ }^\circ\text{K})$ ni tashkil qilsa, termik qarshiliklar, issiqlik uzatish koeffitsiyenti va devor yuzasini yuvadigan qaynoq va sovuq muhitlar haroratlari aniqlansin.

Yechim: Yassi bir qavatli devor orqali issiqlik uzatilishi jarayonining to‘liq termik qarshiligi quyidagi qatlamlar termik qarshiligi summasiga teng:

– qaynoq suyuqlikdan devorga issiqlik uzatishga

$$R_{t,\alpha 1} = 1/\alpha_1 = 1/40 = 0,025 (\text{m}^2 \cdot \text{ }^\circ\text{K}) / \text{Vt};$$

– devorning issiqlik o‘tkazuvchanligiga

$$R_{t,\lambda} = \delta/\lambda = 0,09/9 = 0,01 (\text{m}^2 \cdot \text{ }^\circ\text{K}) / \text{Vt};$$

– devordan sovuq suyuqlikka issiqlik uzatilishiga

$$R_{t,\alpha 2} = 1/\alpha_2 = 1/250 = 0,004 (\text{m}^2 \cdot \text{ }^\circ\text{K}) / \text{Vt}.$$

To‘liq termik qarshilik

$$R_t = 1/\alpha_1 + \delta/\lambda + 1/\alpha_2 = 0,025 + 0,01 + 0,004 = 0,039 (\text{m}^2 \cdot \text{ }^\circ\text{K}) / \text{Vt}.$$

Issiqlik uzatish koeffitsiyenti

$$k = 1/R_t = 1/0,039 = 25,64 \text{ Vt} / (\text{m}^2 \cdot \text{ }^\circ\text{K})$$

Issiqlik oqimining statsionar issiqlik almashinuv rejimida yuza usti zichligi har bir uchastka (qatlam) uchun doimiy bo‘lib, istalgan qatlam parametrlari orqali ifodalanadi.

Masalan:

$$q = \frac{T_{f1} - T_{d1}}{R_{t,\alpha 1}} \quad \text{yoki} \quad q = \frac{T_{d2} - T_{f2}}{R_{t,\alpha 2}}$$

Qaynoq va sovuq muhitlar haroratlarini aniqlaymiz:

$$\begin{aligned} T_{f1} &= T_{d1} + q \cdot R_{t,\alpha1} = 125 + 7500 \cdot 0,025 = 312,5 \text{ } ^\circ\text{C}; \\ T_{f2} &= T_{d2} - q \cdot R_{t,\alpha2} = 50 - 7500 \cdot 0,004 = 20 \text{ } ^\circ\text{C}. \end{aligned}$$

Javob: $k = 25,64 \text{ Vt}/(\text{m}^2 \cdot ^\circ\text{K})$; $T_{f1} = 312,5 \text{ } ^\circ\text{C}$; $T_{f2} = 20 \text{ } ^\circ\text{C}$.

2.5-masala. Agar truba ichidan o'rtacha harorati $T_{f1} = 120 \text{ } ^\circ\text{C}$ bo'lgan suv oqib, atrofdagi havo harorati esa $T_{f2} = -10 \text{ } ^\circ\text{C}$ bo'lsa, diametri $d_1/d_2 = 150 \text{ mm} / 170 \text{ mm}$ ga teng, ochiq havodan o'tkazilgan l m izolyatsiyalanmagan quvurdagi issiqlik yo'qotilishi hisoblab topilsin. Truba materialining issiqlik o'tkazuvchanlik koeffitsiyenti $\lambda = 75 \text{ Vt} / (\text{m} \cdot ^\circ\text{K})$. Suvdan truba devoriga $\alpha_1 = 1000 \text{ Vt} / (\text{m}^2 \cdot ^\circ\text{K})$ va trubadan o'rab turgan havoga issiqlik berish koeffitsiyenti $\alpha_2 = 15 \text{ Vt} / (\text{m}^2 \cdot ^\circ\text{K})$. Shuningdek trubaning ichki va tashqi yuzasidagi haroratlar aniqlansin.

Yechim: Issiq suyuqlikdan devorga issiqlik uzatilishining termik qarshiligi:

$$R_{t,\alpha1} = 1/(d_1 \cdot \alpha_1) = 1/(0,15 \cdot 1000) = 0,00667 \text{ (m} \cdot ^\circ\text{K)} / \text{Vt}.$$

Devor issiqlik o'tkazuvchanligining termik qarshiligi

$$R_{t,\lambda} = \frac{1}{2 \cdot \lambda} \cdot \ln \frac{d_2}{d_1} = \frac{1}{2 \cdot 75} \cdot \ln \frac{170}{150} = 0,000834 \text{ (m} \cdot ^\circ\text{K)} / \text{Vt}.$$

Devordan havoga issiqlik uzatilishining termik qarshiligi

$$R_{t,\alpha2} = 1/(d_2 \cdot \alpha_2) = 1/(0,170 \cdot 15) = 0,392157 \text{ (m} \cdot ^\circ\text{K)} / \text{Vt}.$$

Chiziqli issiqlik oqimining zichligi

$$q_l = \frac{\pi \cdot (T_{f1} - T_{f2})}{R_{t,\alpha1} + R_{t,\lambda} + R_{t,\alpha2}} = \frac{3,14 \cdot [120 - (-10)]}{0,00667 + 0,000834 + 0,392157} = 1021,4 \text{ Vt}/\text{m}^2.$$

Trubaning ichki va tashqi yuzalaridagi haroratlar:

$$T_{d1} = T_{f1} - \frac{q_l \cdot R_{t,\alpha1}}{\pi} = 120 - \frac{1021,4 \cdot 0,00667}{3,14} = 117,83 \text{ } ^\circ\text{C};$$

Javob: $q_l = 1021,4 \text{ Vt} / \text{m}$; $T_{d1} = 117,83 \text{ } ^\circ\text{C}$; $T_{d2} = 117,56 \text{ } ^\circ\text{C}$.

2.6-masala. Agar issiqlik o'tkazuvchanligi R_l va devor qalinligi δ , ichki diametri $d_1 = 8,5 \text{ mm}$ bo'lgan po'lat quvurning yuzalari harorati orasidagi farq $\Delta T = 0,02 \text{ } ^\circ\text{C}$ ga teng bo'lib, quvurning $l = 100 \text{ m}$ li

uchastkasidan atrof-muhitga bir soat davomida $Q_{\tau} = 4,45$ MJ issiqlik yo'qotilsa, uning chiziqli termik qarshiligi aniqlansin. Issiqlik almashinuv rejimi – statsionar. Truba materiali issiqlik o'tkazuvchanligi ko'effitsiyenti $\lambda = 16 \text{ Vt} / (\text{m} \cdot ^\circ\text{K})$.

Javob: $R_{\tau} = 5,081 \cdot 10^{-3} (\text{m} \cdot ^\circ\text{K}) / \text{Vt}$; $\delta = 0,75 \text{ mm}$.

2.7-masala. Quritish kamerasi devorlari qalinligi $\delta_1 = 250$ mm bo'lgan qizil g'isht qatlamidan va qurilish namati qatlamidan bajarilgan. G'isht qatlamining ichki yuzasidagi harorat $T_{d1} = 130$ °C, namat qatlamining tashqi yuzasida esa $T_{d2} = 40$ °C. Qizil g'ishtning issiqlik o'tkazuvchanlik ko'effitsiyenti $0,7 \text{ Vt} / (\text{m} \cdot ^\circ\text{K})$ va qurilish namatining o'tkazuvchanlik ko'effitsiyenti $0,0465 \text{ Vt} / (\text{m} \cdot ^\circ\text{K})$. Kameraning 1 m^2 devori orqali yo'qotiladigan issiqlik miqdori $q = 130 \text{ Vt} / \text{m}^2$ ga teng bo'lishi sharti bilan qatlamlarning o'zaro tegib turadigan sathdagi $T_{1,2}$ harorat va namat qatlami qalinligi hisoblab topilsin.

Javob: $T_{1,2} = 83,5$ °C; $\delta \approx 15,6 \text{ mm}$.

2.8-masala. Agar qozon devorining qalinligi $\delta = 250$ mm, gazlar harorati $T_{g1} = 720$ °C, qozonxonadagi havo harorati $T_{g2} = 25$ °C bo'lsa, bug' qozoni g'isht obmurovkasi yuzasi birligi orqali issiqlik yo'qotilishi va devor yuzasidagi harorat hisoblab topilsin. Gazlardan devor yuzasiga issiqlik berish ko'effitsiyenti $\alpha_1 = 23 \text{ Vt} / (\text{m}^2 \cdot ^\circ\text{K})$ va devordan havoga issiqlik uzatish ko'effitsiyenti $\alpha_2 = 12 \text{ Vt} / (\text{m}^2 \cdot ^\circ\text{K})$. Devorning issiqlik o'tkazuvchanlik ko'effitsiyenti $\lambda = 0,7 \text{ Vt} / (\text{m} \cdot ^\circ\text{K})$.

Javob: $q = 1436,25 \text{ Vt} / \text{m}^2$; $T_{d1} = 657,6$ °C va $T_{d2} = 169,7$ °C.

2.9-masala. Issiqlik o'tkazuvchanlik ko'effitsiyenti $\lambda_1 = 50 \text{ Vt} / (\text{m} \cdot ^\circ\text{K})$ bo'lgan $d_1 / d_2 = 150 \text{ mm} / 160 \text{ mm}$ diametrlil po'lat quvur usti bir xil qalinlikdagi $\delta_2 = \delta_3 = 60$ mm li ikki qavat izolyatsiya bilan qoplangan. Truba ichki yuzasining harorati $T_{d1} = 250$ °C va izolyatsiya tashqi yuzasining harorati $T_{d2} = 50$ °C. Agar truba yuzasiga yotqiziladigan izolyatsiyaning birinchi qatlami issiqlik o'tkazuvchanlik ko'effitsiyenti $\lambda_2 = 0,06 \text{ Vt} / (\text{m} \cdot ^\circ\text{K})$, ikkinchi qatlami ko'effitsiyenti esa $\lambda_3 = 0,12 \text{ Vt} / (\text{m} \cdot ^\circ\text{K})$ bo'lgan materiallardan ishlangan bo'lsa, 1 m quvur izolyatsiyasidan yo'qotiladigan issiqlik miqdori va izolyatsiya qatlamlari tegib turadigan chegaradagi harorat aniqlansin.

Javob: $q_t = 102,2 \text{ Vt} / \text{m}$; $T_{2,3} = 98,22$ °C.

2.10-masala. Agar izolyatsiya qatlamlarining o'rni almashtirilsa, ya'ni kattaroq issiqlik o'tkazish ko'effitsiyentiga ega bo'lgan qatlam bevosita

truba yuzasiga yotqizilsa, 1 m quvur yuzasidan yo'qotilgan issiqlik miqdori qanday o'zgaradi (4-masalaga qar.)? Barcha qolgan shartlar o'zgarishsiz qoldirilsin.

Javob: $q_t = 118,39 \text{ Vt / m}$; $T_{2,3} = 162,1 \text{ }^\circ\text{C}$.

2.2. Konvektiv issiqlik almashinuv

Issiqlik almashinuv qurilmalarini hisob-kitob qilishda va loyiha-lashtirishda suyuqlikdan devorga yoki, aksincha, devordan suyuqlikka konvektiv issiqlik uzatilishidagi issiqlik oqimini hisoblab topish talab etiladi. Bu holda issiqlik oqimi issiqlik uzatish (berish) qonuni - Nyuton qonuniga binoan topiladi:

$$Q = \alpha \cdot (T_d - T_s) \cdot F, \quad (2.9)$$

bu yerda Q – issiqlik oqimi, Vt;

$\Delta T = |T_d - T_s|$ – devor va flyuid orasidagi haroratlar farqi moduli, $^\circ\text{C}$ ($^\circ\text{K}$);

T_d – issiqlik almashinuv yuzasi (devor) harorati, $^\circ\text{C}$ ($^\circ\text{K}$);

T_s – devordan uzoqda oquvchan muhit (flyuid) harorati, $^\circ\text{C}$ ($^\circ\text{K}$);

F – issiqlik almashinish yuzasi maydoni, m^2 ; α – o'rtacha issiqlik berish koeffitsiyenti, $\text{Vt} / (\text{m}^2 \cdot ^\circ\text{K})$.

Issiqlik almashinuv tizimining berilgan geometrik o'lchamlari, devor va oquvchan muhit haroratida issiqlik oqimini hisob-kitob qilish masalasi issiqlik uzatish koeffitsiyentini (α) aniqlashdan iborat bo'ladi.

Issiqlik uzatish koeffitsiyentining kattaligini ayniyat tenglamasini yoki ko'p sonli eksperimental ma'lumotlarga ishlov berish natijasida olinadigan kriterial tenglamani hal qilish yo'li bilan oladilar. Kriterial (mezoniy) tenglama shakli konveksiya turi (erkin yoki majburiy) va suyuqlikning harakatlanish rejimiga (laminar, o'tish yoki turbulent rejimlar) bog'liq.

Umumiy holda ayniyat tenglamasi yoki mezonli (kriterial) tenglama quyidagi ko'rinishga ega:

$$\text{Nu} = f(\text{Gr}, \text{Re}, \text{Pr} \dots), \quad (2.10)$$

bu yerda Nu , Gr , Re , Pr – mezonlar (kriteriyalar).

Mezonlar – fizik kattaliklardan tashkil topgan o'lchamsiz kompleks, u fizik effektlarning nisbatini tavsiflab keladi.

Barcha kriterial mezonlarini ikki asosiy guruhga ajratish mumkin: aniqlanadigan va aniqlaydigan. Noma'lum (izlanayotgan) kattaliklarga ega bo'lgan mezonlar aniqlanadigan mezonlar deb ataladi. Bir xil qiymatlilik shartlari bilan berilgan fizik kattaliklardan tuzilgan (o'xshashlik) mezonlarini aniqlaydigan mezonlar deydilar. Aniqlanadigan mezonlar eksperimentdan topilsa, aniqlaydigan mezonlarga esa eksperiment natijalari bog'liq bo'ladi. Mezonli tenglamasida aniqlanmish bo'lib, Nusselt mezoni (Nu) kelsa, aniqlovchi mezonlar sifatida - Grasgof mezoni (Gr), Reynolds mezoni (Re) va Prandtl mezoni (Pr) keladi.

Nusselt mezoni issiqlik oqimining konvektiv issiqlik berish bilan devor yaqinidagi oquvchan muhitning chegaraviy qatlamidagi konvektiv issiqlik oqimiga issiqlik berish nisbatini tavsiflab keladi.

$$Nu = \frac{\alpha \cdot R_0}{\lambda} \quad (2.11)$$

bu yerda α – issiqlik berish koeffitsiyenti, $Vt / (m^2 \cdot ^\circ K)$;

R_0 – belgilovchi (xarakterli) o'lcham, m;

λ – oquvchan muhitning issiqlik o'tkazuvchanlik koeffitsiyenti, $Vt / (m \cdot ^\circ K)$.

Grasgof mezoni (kriteriysi) termogravitatsion kuchning qayishqoq ishqalanish kuchiga nisbatini tavsiflab keladi

$$Gr = \frac{g \cdot R_0^3}{\nu^2} \cdot \beta \cdot \Delta T, \quad (2.12)$$

bu yerda $g = 9,81 \text{ m/ik}^2$ – erkin tushish tezlashishi;

ΔT – devor va suyuqlik orasidagi haroratlar farqi modeli, $^\circ C$ ($^\circ K$);

β – suyuqlikning hajmiy kengayish koeffitsiyenti, $1/^\circ K$.

Tomchili suyuqliklarning hajmiy kengayish koeffitsiyenti spravochniklarda, masalan, [7,14] da suyuqlik haroratiga bog'liq ravishda berilgan bo'lib, gazlar uchun quyidagi formula bo'yicha hisoblab topiladi:

$$\beta = \frac{1}{T_0}, \quad (2.13)$$

bu yerda T_0 – belgilovchi harorat (Kelvin shkalasi bo'yicha).

Reynolds mezoni inersiya kuchining ishqalanish kuchiga bo'lgan nisbatini tavsiflab keladi:

$$Re = \frac{w_0 \cdot R_0}{\nu}, \quad (2.14)$$

bu yerda w_0 – belgilovchi yoki xarakterli tezlik, m/s;
 R_0 – belgilovchi yoki xarakterli o‘lcham, m;
 ν – oquvchan muhit qovushqoqligining kinematik koeffitsiyenti, m^2 / ik .

Re mezoni qiymatiga ko‘ra suyuqlikning majburiy konveksiyadagi oqish rejimi to‘g‘risida fikr yuritadilar.

Prandtl mezoni molekular ko‘chishining ikki tavsifi nisbatidan iborat: impuls (ν) ko‘chishi va issiqlik (a) ko‘chishi.

$$Pr = \frac{\nu}{a}, \quad (2.15)$$

bu yerda ν – oquvchan muhit qovushqoqligining kinematik koeffitsiyenti, m^2 / ik ;

a – suyuqlikning harorat o‘tkazuvchanlik koeffitsiyenti, m^2 / ik .

Harorat o‘tkazuvchanlik koeffitsiyenti muhitning fizik parametri bo‘lib, uning qiymati haroratga bog‘liq holda ma‘lumotnomalarda keltiriladi.

Funksional bog‘liqlikning muayyan turi ayniyat tenglamalarida formula muallifi tomonidan beriladi. Aslini olganda, eksperiment ma‘lumotlarini approksimatsiyalash uchun har qanday polinomial bog‘liqlikdan foydalanish mumkin.

Mahalliy adabiyotlarda, odatda, approksimasiyalovchi tenglamalar sifatida quyidagi ko‘rinishli daraja funksiyalarini qo‘llaydilar:

$$\overline{Nu} = c \cdot Gr^k \cdot Re^n \cdot Pr^m \cdot \varepsilon_t \cdot \varepsilon_r, \quad (2.16)$$

bu yerda c, n, m, k – empirik koeffitsiyentlar bo‘lib, ular eksperiment ma‘lumotlariga statistika ishlovi berish yo‘li bilan topiladilar;

ε_t – suyuqlikning fizik xossalarning haroratga bog‘liqligini hisobga oladigan tuzatish;

ε_r – muayyan obyekt geometriyasini hisobga oladigan tuzatish.

Modelni qurish va eksperiment natijalariga mezonli formulalar ko‘rinishida ishlov berishda to‘g‘ridan-to‘g‘ri yoki bilvosita ayniyat mezonlariga kiradigan belgilovchi parametrlarni bilish talab etiladi. Konvektiv issiqlik almashinuvining statsionar masalalarida belgilovchi parametrlarga quyidagilarni oid deb hisoblaydilar: belgilovchi o‘lcham (R_0), belgilovchi harorat (T_0) va majburiy konveksiya masalalarida – belgilovchi tezlik (w_0).

Belgilovchi o'lcham (R_0) va belgilovchi harorat (T_0) formula muallifi tomonidan beriladi. Belgilovchi tezlik (w_0) esa uzviylik tenglamasidan topiladi.

$$w_0 = G/(\rho \cdot f), \quad (2.17)$$

bu yerda G – suyuqlik sarfi, kg / ik;

ρ – zichligi, kg / m³;

f – issiqlik tashuvchi o'tishi uchun ko'ndalang kesim maydoni, m².

Diqqat! Mezonli tenglamalarni qo'llashda belgilovchi parametrlar kriterial formulalarga berilgan sharhlarda ko'rsatilgan.

Issiqlik uzatish koeffitsiyentining hisob-kitobi uchun zarur mezonli tenglamalar [4,5,7,14] da keltirilgan.

Issiqlik uzatish koeffitsiyentining mezonli tenglamalar bo'yicha hisob-kitob algoritmi

1. Konvektiv issiqlik almashinuvining turi (erkin yoki majburiy konveksiya) va u ro'y berayotgan obyekt aniqlanadi. So'ng ma'lumot adabiyotlarida [4,5,7,14] ushbu konveksiya turiga oid mezonli formulalarni topadilar.

2. Mezonli formulalarga berilgan sharhlarda bayon etilgan talablarga muvofiq, muayyan parametrlar topiladi:

– o'lcham;

– oquvchan muhitning fizik xossalari (ν , λ , Pr va h.k.) izlanadigan ma'lumot jadvallaridan [7] haroratni topadilar;

– quvurlar va kanalarda suyuqlik majburiy tarzda oqqanida yoki trubalar va kanalga jamlangan truba tutamlari tashqi tarafdan yuvilganida suyuqlikning belgilovchi tezligini uzluksizlik integral tenglamasidan kelib chiqib hisoblab topadilar.

3. Muhitning oqim rejimini aniqlaydilar:

– majburiy harakatda Reynolds (Re) mezoniga (Re) ko'ra;

– erkin harakatda Reley (Ra) mezoniga (Ra) ko'ra. Oquvchan muhitning harakatlanish rejimiga bog'liq ravishda mezoniy formulaga aniqlik kiritiladi.

4. Mezonli tenglamaga ko'ra beo'lchov issiqlik berish koeffitsiyenti - Nusselt soni (Nu) topiladi.

5. Nusselt mezonini aniqlashdan foydalanib, konvektiv issiqlik uzatish koeffitsiyenti α hisoblab topiladi

$$\alpha = Nu \frac{\lambda}{R_0}, \quad (2.18)$$

2.11-masala. Diametri $d = 50$ mm va uzunligi $\ell = 0,75$ m li trubkadan bajarilgan isitgich $T_f = 30$ °C haroratli suv solingan bak ichiga vertikal tarzda joylangan. Uning yuzasi haroratini butun uzunligi bo'ylab doimiy va $T_d = 45,5$ °C ga teng deb hisoblab, isitgich vaqt birligi davomida uzatiladigan issiqlik miqdori aniqlansin.

Yechim: Isitgich yuzasidagi va atrof-muhitning berilgan harorat qiymatlarida masala yechimi va issiqlik uzatish koeffitsiyentini aniqlashga borib taqaladi. Vertikal yuza yaqinidagi erkin konveksiya jarayonini hisob-kitob qilish uchun M.A. Mixeyev formulasini [7,9] qo'llaymiz. Unga ko'ra belgilovchi, hal qiluvchi harorat sifatida chegara qatlamning o'rtacha harorati olingan $T_m = (45,5 + 30) \cdot 0,5 = 37,75$ °C.

Ushbu haroratga ko'ra suv quyidagi xossalarga ega bo'ladi [5,7,14]:

$$\lambda = 0,63 \text{ Vt} / (\text{m} \cdot ^\circ\text{K}); c_p = 4187 \text{ J} / (\text{kg} \cdot ^\circ\text{K}); \nu = 0,687 \cdot 10^{-6} \text{ m}^2 / \text{ik}; \\ \rho = 993,1 \text{ kg} / \text{m}^3; \beta = 0,36 \cdot 10^{-3} \text{ K}^{-1}; Pr_f = 4,52; Pr_d = 3,26.$$

Belgilovchi o'lcham sifatida isitgich uzunligi qabul qilinadi $R_0 = \ell = 0,75$ m.

Grasgof mezoni

$$Gr = \left(\frac{g \cdot l^3}{\nu^2} \right) \cdot \beta \cdot (T_d - T_f) = \left(\frac{9,8 \cdot 0,75^3}{0,687^2 \cdot 10^{-6}} \right) \cdot 0,36 \cdot 10^{-3} \cdot (45,5 - 30) = 0,489 \cdot 10^{11}$$

$Ra = Gr \cdot Pr = 0,489 \cdot 10^{11} \cdot 4,52 = 2,21 \cdot 10^{11} > 2 \cdot 10^7$ bo'lganligi sababli, harakat rejimining turbulent va empirik koeffitsiyentlari quyidagi qiymatlarni oladilar:

$$c = 0,135; n = 0,33.$$

Nusselt mezoni

$$Nu = 0,135 \cdot (Gr \cdot Rg)^{0,33} = 0,135 \cdot (1,5 \cdot 10^{11})^{0,33} = 711,16.$$

Issiqlik berish koeffitsiyenti

$$\alpha = Nu \cdot \lambda / R_0 = 711,16 \cdot 0,63 / 0,75 = 597,37 \text{ Vt} / (\text{m}^2 \cdot ^\circ\text{K})$$

Suvga vaqt birligi davomida uzatiladigan issiqlik miqdori

$$Q = \alpha \cdot (T_d - T_f) \cdot \pi \cdot d \cdot \ell = 597,37 \cdot (45,5 - 30) \cdot 3,14 \cdot 0,05 \cdot 0,75 = 1090,3 \text{ Vt}.$$

Javob: $Q = 1090,3 \text{ Vt}$.

2.12-masala. $d = 90 \text{ mm}$ li truba bo'ylab $\overline{w} = 6 \text{ m/ik}$ tezlik bilan havo oqib o'tadi. Agar havoning o'rtacha harorati $T_f = 100 \text{ }^\circ\text{C}$ bo'lsa, issiqlik berish koeffitsiyentining o'rtacha qiymati aniqlansin.

Yechim: Muayyan (aniq) harorat sifatida $T_0 = T_f = 100 \text{ }^\circ\text{C}$ ni olamiz. Muayyan haroratda havo quyidagi xossalarga ega [7]:

$$\lambda = 0,0321 \text{ Vt} / (\text{m} \cdot \text{ }^\circ\text{C}); \nu = 23,13 \cdot 10^{-6} \text{ m}^2 / \text{ik}.$$

Ma'lum o'lcham sifatida truba diametrini olamiz $R_0 = d = 0,09 \text{ m}$.

Reynolds mezonini

$$Re = \frac{w \cdot d}{\nu} = \frac{6 \cdot 0,09}{23,13 \cdot 10^{-6}} = 23346,3, \quad Re > 10^4 \text{ bo'lgani uchun, bu holda}$$

oqim rejimi turbulent bo'ladi.

Nusselt mezonini [4,5,7,14]

$$Nu = 0,018 \cdot Re^{0,8} = 0,018 \cdot 23346,3^{0,8} = 56,21.$$

$$\alpha = Nu \frac{\lambda}{R_0} = 56,21 \cdot \frac{0,0321}{0,09} = 20,05 \text{ Vt/m}^2 \cdot \text{ }^\circ\text{K}$$

Javob: $\alpha = 20,05 \text{ Vt} / (\text{m}^2 \cdot \text{ }^\circ\text{K})$.

2.13-masala. $d = 80 \text{ mm}$ li va uzunligi $\ell = 4,4 \text{ m}$ bo'lgan truba bo'ylab $\overline{w} = 1,2 \text{ m}$ / ik tezlik bilan suv oqmoqda. Agar suvning o'rtacha harorati $T_f = 50 \text{ }^\circ\text{C}$, devor harorati esa $T_d = 70 \text{ }^\circ\text{C}$ bo'lsa, issiqlik berish koeffitsiyentining o'rtacha qiymati aniqlansin.

Yechim: Asosiy (hal qiluvchi) harorat $T_f = 50 \text{ }^\circ\text{C}$ bo'lganida suvning fizik xossalari quyidagicha: $\lambda = 0,648 \text{ Vt} / (\text{m} \cdot \text{ }^\circ\text{K})$; $\nu = 5,56 \cdot 10^{-7} \text{ m}^2 / \text{s}$; $Pr_f = 3,54$. $T_d = 70 \text{ }^\circ\text{C}$ bo'lganida suv uchun Prandtl mezonini $Pr_{wd} = 2,55$.

Suyuqlik truba ichidan majburiy harakatlanishida Reynolds mezonini asosiy (belgilovchi) bo'lib hisoblanadi:

$$Re = \frac{w \cdot d}{\nu} = \frac{1,2 \cdot 0,08}{5,56 \cdot 10^{-7}} = 17,27 \cdot 10^4$$

$Re = 17,27 \cdot 10^4 > Re = 10^4$ bo'lganligi sababli, bu holda oqim rejimi turbulent bo'ladi.

Bu holda mezoniniy formula quyidagi ko'rinishga ega [4,5,7,14]

$$Nu = 0,021 \cdot Re^{0,8} \cdot Pr_f^{0,43} \cdot \varepsilon_i \cdot \varepsilon_s;$$

$$\varepsilon_s = (Pr_f / Pr_w)^{0,25} = (3,54 / 2,55)^{0,25} = 1,09;$$

$$Nu = 0,21 \cdot (17,27 \cdot 10^4)^{0,8} \cdot 3,54^{0,43} \cdot 1,09 = 610,26.$$

$\ell/d = 55 > 50$ bo'lgani sababli, gidrodinamik stabilizatsiyaning boshlang'ich uchastkasiga tuzatish $\epsilon_f = 1$ ga teng.

Nusselt sonini bilib, issiqlik berish koeffitsiyentini topamiz:

$$\alpha = \text{Nu} \frac{\lambda}{d} = 610,26 \frac{0,648}{0,08} = 4393,1 \text{ Vt/m}^2 \cdot \text{°K}$$

Javob: $\alpha = 4393,1 \text{ Vt / (m}^2 \cdot \text{°K)}$.

2.14-masala. $d = 20$ mm diametrli va uzunligi $\ell = 1,2$ m trubadan bajarilgan elektr isitgich, solishtirma elektr qarshiligi $\rho_p = 0,2$ (Om \cdot mm²)/m, $u w = 0,75$ m/ik tezlikdagi ko'ndalang havo oqimi va harorat $T_f = 20$ °C bilan shamollatiladi. Agar isitgich yuzasi harorati $T_d = 95$ °C dan oshmasa, isitgichning havoga vaqt birligida uzatayotgan issiqlik miqdori va undagi yo'l qo'yiladigan tok kattaligi aniqlansin.

Yechim: $T_f = 20$ °C haroratda havo quyidagi fizik xossalarga ega bo'ladi [7]:

$$v = 15,06 \cdot 10^{-6} \text{ m}^2 / \text{ik}; \lambda = 0,0259 \text{ Vt / (m} \cdot \text{°K)}; \text{Pr}_f = 0,703.$$

Reynolds mezonini

$$\text{Re} = w \cdot d/v = 0,75 \cdot 0,02/(15,06 \cdot 10^{-6}) = 996.$$

$\text{Re} = 996$ bo'lganida issiqlik uzatilish hisobini trubani ko'ndalang aylanib oqib o'tishda [4,5,7,14] tenglama bo'yicha amalga oshirish mumkin:

$$\text{Nu} = 0,52 \cdot \text{Re}^{0,5} \cdot \text{Pr}_f^{0,37} = 0,52 \cdot 996^{0,5} \cdot 0,703^{0,37} = 0,52 \cdot 31,56 \cdot 0,88 = 14,5.$$

Issiqlik berish koeffitsiyenti

$$\alpha = \text{Nu} \cdot \lambda/d_0 = 14,5 \cdot 0,0259/0,02 = 18,8 \text{ Vt / (m}^2 \cdot \text{°K)}$$

Istitgichdan havoga uzatiladigan issiqlik miqdori

$$Q = \alpha \cdot (T_d - T_f) \cdot F = 18,8 \cdot (95 - 20) \cdot \pi \cdot 0,02 \cdot 1,2 = 106,26 \text{ Vt}.$$

Elektr toki isitgichdan o'tganida ajralib chiqqan issiqlik miqdorini atrofda havoga uzatilgan issiqlik miqdoriga tenglashtirib, tokning yo'l qo'yiladigan kattaligini topamiz:

$$Q = I^2 \cdot R_{el};$$

$$I = \sqrt{Q/R_{el}} = \sqrt{Q/[\rho_p \cdot l \cdot 4 \cdot (\pi \cdot d^2)]} = \sqrt{106,26/[0,2 \cdot 1,2 \cdot 4 \cdot (3,14 \cdot 20^2)]} = 372,86 \text{ A.}$$

Javob: $Q = 106,26 \text{ Vt}$; $I = 372,86 \text{ A}$.

2.15-masala. Korpusi silindrsimon shaklga ega bo'lgan va erkin havo oqimi bilan sovutiladigan gorizontal issiqlik almashtirgichning 1 m^2 yuzasidan konveksiya orqali yo'qotiladigan issiqlik miqdori hisoblab topilsin. Issiqlik almashtirgich korpusining tashqi diametri $d = 400 \text{ mm}$, yuzasining harorati $T_d = 160 \text{ }^\circ\text{C}$, xonadagi havo harorati $T_f = 20 \text{ }^\circ\text{C}$.

Javob: $\alpha = 7,3 \text{ Vt} / (\text{m}^2 \cdot \text{ }^\circ\text{K})$; $q = 1025 \text{ Vt} / \text{m}^2$.

2.16-masala. 1-masala shartiga ko'ra kamroq issiqlik yo'qotish maqsadida issiqlik almashgich korpusi issiqlik izolyatsiyasi qatlami bilan qoplangan. Agar qalinligi 50 mm li issiqlik izolyatsiyasi qatlami yotqizilganidan so'ng izolyatsiyaning tashqi yuzasidagi harorat T_d endi $40 \text{ }^\circ\text{C}$ ga yetib, xonadagi harorat T_f esa avvalgiday $+20 \text{ }^\circ\text{C}$ qolgan bo'lsa, izolyatsiyaning tashqi yuzasida issiqlik almashtirgich yuzasidan issiqlik yo'qotilishining zichligi q , Vt/m^2 topilsin.

Javob: $q = 86 \text{ Vt} / \text{m}^2$.

2.17-masala. Agar plita yuzasi harorati $T_d = 80 \text{ }^\circ\text{C}$, yuzadan uzoqdagi atrof muhit harorati $T_f = 20 \text{ }^\circ\text{C}$ ekanligi ma'lum bo'lsa, balandligi $H = 1,5 \text{ m}$ bo'lgan vertikal plitadan atrofidagi havoga issiqlik berish koeffitsiyenti aniqlansin.

Javob: $\alpha = 6 \text{ Vt} / (\text{m}^2 \cdot \text{ }^\circ\text{K})$.

2.18-masala. Agar 3-masala shartlariga ko'ra plita balandligi 4 marta ko'tarilib, qolgan boshqa shartlar esa vertikal plitaning atrofidagi havoga issiqlik berish koeffitsiyenti qanday o'zgaradi?

Javob: $\alpha_1 / \alpha_2 = 1$.

2.19-masala. Tashqi diametri $d = 16 \text{ mm}$ bo'lgan trubka shaklidagi suvli kalorimetr havoning ko'ndalang oqimiga joylangan. Havo $w = 3 \text{ m}$ / ik tezlik bilan kalorimetr o'qiga nisbatan 90° burchak ostida harakatlanib, o'rtacha $T_f = 20 \text{ }^\circ\text{C}$ haroratga ega. Statsionar issiqlik rejimida kalorimetrning tashqi yuzasida quyidagi doimiy o'rtacha harorat $T_d = 80 \text{ }^\circ\text{C}$ o'rnatiladi.

Trubkadan havoga issiqlik berish koeffitsiyenti va kalorimetr uzunligining birligiga issiqlik oqimi hisoblab topilsin.

Javob: $\alpha = 46,9 \text{ Vt} / (\text{m}^2 \cdot \text{°K})$; $q_t = 141,37 \text{ Vt} / \text{m}$.

2.20-masala. Diametri $d = 25 \text{ mm}$ bo'lgan silindrsimon trubka ko'ndalang suv oqimi yordamida sovutiladi. Oqim tezligi $w = 1 \text{ m} / \text{ik}$. Suvning o'rtacha harorati $\overline{T_f} = 10 \text{ °C}$, trubka yuzasi harorati esa $T_d = 60 \text{ °C}$. Trubka yuzasidan sovituvchi suvga issiqlik berish koeffitsiyenti aniqlansin.

Javob: $\alpha = 6807,7 \text{ Vt} / (\text{m}^2 \cdot \text{°K})$.

2.21-masala. Bir tomoni $a = 20 \text{ mm}$ va uzunligi $\ell = 1400 \text{ mm}$ bo'lgan kvadrat kesimli kanaldan $w = 3,5 \text{ m} / \text{ik}$ tezlik bilan suv oqib o'tmoqda. Agar kanal uzunligi bo'yicha o'rtacha suv harorati $\overline{T_f} = 30 \text{ °C}$, kanal ichki yuzasining harorati $T_d = 90 \text{ °C}$ bo'lsa, kanal devoridan issiqlik berish koeffitsiyenti hisoblab topilsin.

Javob: $\alpha = 15493 \text{ Vt} / (\text{m}^2 \cdot \text{°K})$.

2.22-masala. Agar kvadrat kesimli kanal teng tomonli uchburchak kesimli kanal bilan almashtirilsa, 7-masala shartiga binoan issiqlik berish koeffitsiyenti qanday o'zgaradi? Bunda kanalning ko'ndalang kesimi maydoni va suvning harakatlanish tezligi o'zgarmay qoladi.

Javob: Issiqlik berish koeffitsiyenti 2,6 % ga kattalashadi.

2.3. Bug'lar kondensatsiyalanib, suyuqliklar qaynashida konvektiv issiqlik almashinuv

Suyuqlikning fazaviy holatiga bog'liq ravishda ajratishadi (различают), v bir fazali muhitdagi konvektiv issiqlik almashinuvi va fazaviy o'zgarishlarda konvektiv issiqlik almashinuvini farqlaydilar. Moddaning agregat holati o'zgarishidagi (kondensatsiyalanish va qaynashda) issiqlik almashinish jarayonini konvektiv issiqlik almashinuviga oid deb bilib, uni Nyuton issiqlik uzatish qonuniga binoan hisoblab topadilar:

$$Q = \alpha \cdot \Delta T \cdot F, \quad (2.19)$$

bu yerda α – kondensatsiyalanish yoki qaynashda issiqlik berish (uzatish) koeffitsiyenti, $\text{Vt} / (\text{m}^2 \cdot \text{°K})$;

F – issiqlik almashinish yuzasi maydoni, m^2 ;

ΔT – suyuqlik va devor haroratlari o'rtasidagi farq (haroratdagi farqlanish), °C (°K).

Kondensatsiyalanish jarayoni $T_d < T_n$ sharti bilan ro‘y berib, shu sababli kondensatsiyalanishda haroratlar farqi quyidagiga teng:

$$\Delta T = T_n - T_d. \quad (2.20)$$

Qaynashda, aksincha, devor harorati ana shu bosimdagi to‘yinish haroratiga nisbatan qizib ketishi lozim, bu holda:

$$\Delta T = T_d - T_n. \quad (2.21)$$

Modda agregat holatining o‘zgarishi doimiy haroratda ro‘y berib, fazaviy o‘tish solishtirma issiqligi r ning ajralib chiqishi (kondensatsiyalanishda) yoki yutilishi (qaynashda) bilan tavsiflanadi, J / kg (suv uchun bug‘ hosil bo‘lishining yashirin issiqligi) (2.1-rasmga qar.).

Fazaviy o‘tish r solishtirma issiqligi qiymatini to‘yingan quruq bug‘ning to‘yinish haroratiga yoki berilgan bosimiga ko‘ra suv va suv bug‘ining termodinamik xossalari [8,14] jadvallari (bosim $p_n < 100$ kPa dan past bo‘lganida) yoki 2.1-jadvaldagi ma‘lumotlardan foydalanib topish mumkin.

2.1-jadval

To‘yinish harorati va bug‘ hosil bo‘lishi issiqligining bosimga bog‘liqligi

p, MPa	$T_n, ^\circ C$	$r, kJ / kg$	p, MPa	$T_n, ^\circ c$	$r, kJ / kg$
0,00123	10	2477,4	0,00737	40	2406,5
0,00234	20	2453,8	0,01234	50	2382,5
0,00424	30	2430,2	0,1000	99,63	2258,2

Aytish lozimki, kondensatsiya r da issiqlik berishning hisobiy formulalarini kilogrammga Joullarda (J / kg) qo‘yish lozim

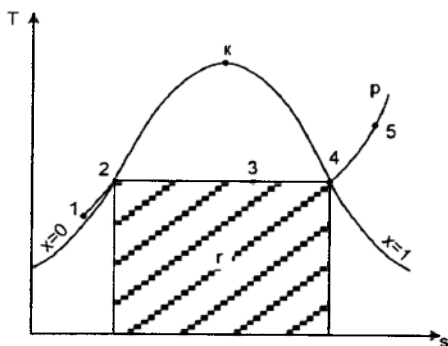

2.1-rasm. Suv bug'ining fazaviy T, s - diagrammasi

Statsionar kondensatsiyalanish jarayonida yoki qaynashda fazaviy o'tishning issiqlik oqimi

$$Q = G \cdot r, \quad (2.22)$$

bu yerda Q – kondensatsiyalanishda bug'dan devorga yoki qaynashda devordan qaynayotgan suyuqlikka boradigan issiqlik oqimi, Vt;

G – kondensat yoki bug' fazasi sarfi, kg/ik;

r – fazaviy o'tish solishtirma issiqligi, J / kg.

Moddaning fazaviy o'zgarishlarida issiqlik almashinuvining asosiy tenglamasi – issiqlik balansi (muvozanati) tenglamasi

$$Q = G \cdot r = \alpha \cdot \Delta T \cdot F. \quad (2.23)$$

bu yerda G – kondensat yoki bug' fazasi sarfi, kg / ik;

r – fazaviy o'tish solishtirma issiqligi, J / kg;

α – kondensatsiyalanish yoki qaynashda issiqlik berish (uzatish) koeffitsiyenti, Vt / (m² · °K);

ΔT – suyuqlik va devor haroratlari o'rtasidagi farq (haroratdagi farqlanish), °C (°K);

F – issiqlik almashinish yuzasi maydoni, m².

Bug'lar kondensatsiyalanishida issiqlik berilishi

Kondensatsiya – bug'ning (gazning) suyuq yoki qattiq holatga o'tish jarayonidir (desublimatsiya). Bug' kondensatsiyalanganida fazaviy o'tish

issiqligi (bug'lik hosil bo'lishining yashirin issiqligi) ajralib chiqib, shu sababli kondensatsiya jarayoni issiqlik almashinuvi bilan uzviy bog'liq.

Vertikal yuzadagi bug'lar kondensatsiyalanganida issiqlik uzatish koeffitsiyentining o'rtacha qiymati Nusselt formulasi bo'yicha hisoblab topiladi:

$$\bar{\alpha} = 0,943 \cdot \sqrt[4]{\frac{g \cdot r \cdot \rho_{pl}^2 \cdot \lambda_{pl}^3}{\mu_{pl} \cdot (T_n - T_d) \cdot H'}} \quad (2.24)$$

bu yerda $g = 9,81 \text{ m / ik}^2$ – erkin tushish tezlashishi;

r – bug' hosil bo'lishining yashirin issiqligi, J / kg;

λ_{pl} – kondensat plenkasining issiqlik o'tkazish koeffitsiyenti, Vt / (m · °K);

μ_{pl} – kondensat qayishqoqligining dinamik koeffitsiyenti, Pa · ik;

ρ_{pl} – plenka zichligi, kg / m³;

H' – vertikal yuza balandligi, m;

T_n – to'yinish harorati, °C (°K);

T_d – issiqlik almashinuv yuzasi (devor) harorati, °C (°K).

Qiya yuzada kondensatsiyalanishdagi o'rtacha issiqlik berish koeffitsiyenti quyidagi formula bo'yicha hisoblab topiladi:

$$\bar{\alpha}_{nakt} = \bar{\alpha}_{verik} \cdot \sqrt{\cos \varphi}, \quad (2.25)$$

bu yerda $\bar{\alpha}_{verik}$ – vertikal yuza uchun issiqlik berish koeffitsiyenti;

φ – og'irlik kuchi va o'q yo'nalishi orasidagi, issiqlik almashinuvi yuzasi bo'ylab yo'naltirilgan burchak.

Gorizontal trubada plenkali kondensatsiyalanishda o'rtacha issiqlik berish koeffitsiyenti laminar oqimda kondensat plenkalari Nusselt formulasiga binoan hisoblab topilib, u ushbu holda quyidagicha ko'rinishga ega bo'ladi:

$$\bar{\alpha} = 0,728 \cdot \sqrt[4]{\frac{g \cdot r \cdot \rho_{pl}^2 \cdot \lambda_{pl}^3}{\mu_{pl} \cdot (T_n - T_d) \cdot d_{tr}}}, \quad (2.26)$$

bu yerda $g = 9,81 \text{ m / ik}^2$ – erkin tushish tezlashishi;

r – bug' hosil bo'lishining yashirin issiqligi, J / kg;

λ_{pl} – kondensat plenkasining issiqlik o'tkazish koeffitsiyenti, Vt / (m · °K);

μ_{pl} – kondensat qayishqoqligining dinamik koeffitsiyenti,
 $Pa \cdot ik$;

ρ_{pl} – plenka zichligi, kg / m^3 ;

T_n – t o‘yinish harorati, $^{\circ}C$ ($^{\circ}K$);

T_d – issiqlik almashinuv yuzasi (devor) harorati, $^{\circ}C$ ($^{\circ}K$);

d_{tr} – trubaning tashqi diametri, m.

Ushbu formula quyidagi shart bajarilganida plenkaning laminar oqish rejimi uchun to‘g‘ri keladi:

$$d_{tr} < 20 \cdot \sqrt{\frac{\sigma_{pl}}{g \cdot \rho_{pl}}}, \quad (2.27)$$

bu yerda σ_{pl} – plenka yuzasining taranglik kuchi, N / m ;

ρ_{pl} – plenka zichligi, kg / m^3 .

Diqqat! Suyuq plenkaning fizik xossalari spravochnikdan [7] ushbu bosimdagi to‘yinish haroratiga ko‘ra topiladi.

Plenkaning issiqlik berishning lokal koeffitsiyentlari, to‘lqinli va turbulent oqimidagi issiqlik berish koeffitsiyentini, shuningdek kondensat plenkasining qalinligini hisoblab topish uchun formulalar [4,7,9,14] da keltirilgan.

Suyuqliklar qaynashida issiqlik uzatilishi

Qaynash – to‘yinish harorati yoki undan yuqori haroratda suyuqlik hajmi ichida intensiv (jadal) bug‘ hosil bo‘lish jarayonidir.

Qaynashda fazaviy o‘tish issiqligi yutilib, shuning uchun statsionar qaynash jarayonini amalga oshirish uchun issiqlik keltirish talab etiladi.

Katta hajmda pufakli va plenkali qaynashda issiqlik uzatilishi hisob-kitobi formulalarini keltiramiz.

Suvning katta hajmda qaynashida issiqlik berilishini hisob-kitob qilish maqsadida quyidagi formulalardan foydalanadilar:

$$\alpha = 38,7 \cdot \Delta T^{2,33} \cdot p_n^{0,5}, \quad (2.28)$$

$$\alpha = 3,0 \cdot q^{0,7} \cdot p_n^{0,15}, \quad (2.29)$$

(2.28) formulani pufakli qaynashga oid birinchi turdagi chekli sharoitlar hisob-kitob qilishda qo‘llaydilar. Bu holda rostlanadigan (berilgan) kattalik bo‘lib devor harorati keladi va bundan kelib chiqib, suyuqlikning qizib ketishi ($\Delta T = T_d - T_n$), formulani (2.29) esa ikkinchi turdagi chekli

sharoitlardagi qaynash hisob-kitoblarida ishlatadilar (berilgan kattalik – devor yuzasidagi issiqlik oqimining zichligi (q)). (2.29) formula bo'yicha α ni aniqlab, devorning qizib ketganligi (chegaraviy qatlamdagi suyuqlik) va devor haroratini osonlik bilan topish mumkin.

$$\Delta T = q/\alpha \Rightarrow T_d = T_i + q/\alpha \quad (2.30)$$

2.23-masala. Diametri $d = 40$ mm va uzunligi $\ell = 3$ m bo'lgan gorizontal truba tashqi yuzasida $p_n = 1,013 \cdot 10^5$ Pa bosimda quruq to'yingan suv bug'i kondensatsiyalanadi. Truba yuzasi harorati $T_d = 95,5$ °C. Bug'dan trubaga o'rtacha issiqlik berish koeffitsiyenti va truba yuzasida kondensatsiyalanadigan bug' miqdori G aniqlansin.

Yechim: To'yingan quruq bug'ni gorizontal trubada plenkali kondensatsiyalashda o'rtacha issiqlik berish koeffitsiyentini quyidagi formula bo'yicha aniqlash mumkin

$$\bar{\alpha} = 0,728 \cdot \sqrt[4]{\frac{g \cdot r \cdot \rho_{pl}^2 \cdot \lambda_{pl}^3}{\mu_{pl} \cdot (T_n - T_d) \cdot d_{tr}}}$$

u plenkani laminar oqimi uchun to'g'ri keladi.

$p_n = 1,013 \cdot 10^5$ Pa [7, 14] bo'lganida $T_n = 100$ °C.

To'yinish harorati $T_n = 100$ °C bo'lganida kondensatning fizik xossalari:

$$\begin{aligned} \rho_{pl} &= 958,4 \frac{kg}{m^3}; & \lambda_{pl} &= 68,3 \cdot 10^{-2} \frac{Wt}{m \cdot ^\circ C}; \\ \mu_{pl} &= 282,5 \cdot 10^{-6} Pa \cdot ik; \\ r_p &= 2256,8 \cdot 10^3 \frac{kJ}{kg}; & \sigma_{pl} &= 588,6 \cdot 10^{-4} \frac{N}{m}. \end{aligned}$$

Laminar plenkali oqish rejimi sharti

$$d < 20 \cdot \left(\frac{\sigma_{pl}}{g \cdot \rho_{tr}} \right) = 20 \cdot \left(\frac{588,6 \cdot 10^{-4}}{9,8 \cdot 958,4} \right)^{0,5} = 0,050 m = 50 mm,$$

$d_{tr} = 20$ mm < 50 mm, bundan kelib chiqib, plenkani oqish rejimi laminar rejim bo'ladi.

Issiqlik berish koeffitsiyenti

$$\alpha = 0,728 \cdot \sqrt[4]{\frac{9,8 \cdot 2256,8 \cdot 10^3 \cdot (68,3 \cdot 10^{-2})^3}{282,5 \cdot 10^{-6} \cdot (100 - 95,5) \cdot 0,04}} = 13751,5 \frac{Wt}{(m^2 \cdot ^\circ K)}$$

Issiqlik muvozanati tenglamasidan hosil bo'ladigan kondensat miqdorini aniqlaymiz:

$$G \cdot r = \alpha \cdot \Delta T \cdot F;$$

$$G = \frac{\alpha \cdot \Delta T}{r} \cdot \pi \cdot d \cdot l =$$

$$\frac{13751,5 \cdot (100 - 95,5)}{2256,8 \cdot 10^3} \cdot 3,14 \cdot 0,04 \cdot 3 = 10,33 \cdot 10^{-3} \text{ kg/ik}$$

Javob: $\alpha = 13751,5 \text{ Vt/m}^2 \cdot \text{°K}$; $G = 10,33 \cdot 10^{-3} \text{ kg/ik}$.

2.24-masala. Katta hajmda pufakchali qaynash rejimida issiqlik berish koeffitsiyenti va qizish yuzasi harorati aniqlansin. Suv bosimi 2 MPa, issiqlik oqimi zichligi esa $q = 0,8 \text{ MVt/m}^2$.

Yechim: Suvning pufakchalar bilan qaynashida issiqlik uzatish koeffitsiyenti

$$\alpha = 3,0 \cdot q^{0,7} \cdot p_n^{0,15}$$

$$p_n = 2 \text{ MPa} = 2 \cdot 10^6 \text{ Pa} = 20 \text{ bar}; \quad T_n = 179,88 \text{ °C};$$

$$\alpha = 3,0 \cdot (0,8 \cdot 10^6)^{0,7} \cdot 20^{0,15} = 63743,9 \text{ Vt/(m}^2 \cdot \text{°K)}.$$

Qizish (isish) yuzasi haroratini quyidagi tenglamadan aniqlash mumkin:

$$q = \alpha \cdot \Delta T = \alpha \cdot (T_d - T_n);$$

$$\Delta T = \frac{q}{\alpha} = \frac{8 \cdot 10^5}{63743,9} = 12,55 \text{ °C}$$

$$T_d = T_n + \Delta T = 179,88 + 12,55 = 192,43 \text{ °C}.$$

Javob: $\alpha = 63743,9 \text{ Vt/(m}^2 \cdot \text{°K)}$; $T_d = 192,43 \text{ °C}$.

2.25-masala. 40 mm diametrlil gorizontal trubada 0,27 MPa bosimda suv plenkali qaynashi yuz bermoqda. Yuza harorati 160 °C. Devordan suvga issiqlik berish koeffitsiyenti hisoblab topilsin.

Yechim: Issiqlik berish koeffitsiyentini quyidagi formula bo'yicha hisoblab topamiz

$$\bar{\alpha} = 0,728 \cdot \sqrt{\frac{g \cdot r \cdot \rho'' \cdot (\rho' - \rho'') \cdot \lambda_{pl}^3}{\mu_{pl} \cdot \Delta T \cdot d_{tr}}}$$

Hal qiluvchi harorat $T_0 = T_n = 130 \text{ }^\circ\text{C}$.

Suv bug'ining ana shu haroratdagi va $0,27 \text{ MPa}$ bosimdagi fizik xossalari [7,8]:

$$r = 2174,3 \text{ kJ / kg}; \rho'' = 1,496 \text{ kg / m}^3; \mu_{pl} = 13,24 \cdot 10^{-6} \text{ Pa} \cdot \text{ik};$$

$$\lambda_{pl} = 2,686 \cdot 10^{-2} \text{ Vt / (m} \cdot \text{ }^\circ\text{K)}; \rho' = 934,8 \text{ kg / m}^3.$$

$$\alpha = 0,728 \cdot \sqrt[4]{\frac{9,8 \cdot 2174,3 \cdot 10^3 \cdot 1,496 \cdot (934,8 - 1,496) \cdot (2,686 \cdot 10^{-2})^3}{13,24 \cdot 10^{-6} \cdot (160 - 130) \cdot 0,04}} = 436,4 \text{ Vt / (m} \cdot \text{ }^\circ\text{K)}$$

Javob: $\alpha = 436,4 \text{ Vt / (m}^2 \cdot \text{ }^\circ\text{K)}$.

2.26-masala. Bug' bosimi $p_n = 1,98 \cdot 10^5 \text{ Pa}$, barcha qolgan ma'lumotlar esa o'zgarishsiz qolishi sharti bilan 2.23-masalani yeching. Hisob-kitob natijalarini 1-masala javobi bilan solishtiring.

Javob: $\alpha = 10950 \text{ Vt / (m}^2 \cdot \text{ }^\circ\text{K)}$; $G = 0,0158 \text{ kg / ik}$.

2.27-masala. Agar truba diametri 3 marta kattalashtirilib, biroq bug' bosimi, dam, oqim kuchi (napor) harorati va truba uzunligi o'zgartirmay qoldirilsa, issiqlik berish koeffitsiyenti va gorizontl truba yuzasida vaqt birligi davomida kondensatsiyalanayotgan to'yingan quruq suv bug'i miqdori qanchaga o'zgaradi?

Javob: Issiqlik berish koeffitsiyenti 1,316 marta kichrayadi; vaqt birligi davomida kondensasiyalanadigan bug' miqdori 2,28 marta ko'payadi.

2.28-masala. 20 mm diametrligi va balandligi $H = 2 \text{ m}$ vertikal trubaning tashqi yuzasida $p_n = 1,98 \cdot 10^5 \text{ Pa}$ bosimda to'yingan quruq suv bug'i kondensatsiyalanadi. Truba yuzasi harorati $T_d = 115 \text{ }^\circ\text{C}$.

Balandligiga ko'ra bug'dan trubaga o'rtacha issiqlik berish koeffitsiyenti va truba yuzasida kondensasiyalanadigan bug' miqdori, G , kg / s , aniqlansin.

Javob: $\alpha = 6740 \text{ Vt / (m}^2 \cdot \text{ }^\circ\text{K)}$; $G = 7 \text{ kg / s}$.

2.29-masala. Gorizontl kondensatorlarda $p = 1,013 \cdot 10^5 \text{ Pa}$ bosimda $0,278 \text{ kg/i}$ to'yingan quruq suv bug'ini kondensasiyalash talab etiladi. Kondensatorning tashqi diametri $d = 0,03 \text{ m}$ va uzunligi $\ell = 3,5 \text{ m}$ bo'lgan trubalari soni aniqlansin. Trubalar devori harorat stenki trub $T_d = 80 \text{ }^\circ\text{C}$.

Javob: $n = 10$ dona (sht).

2.30-masala. Diametri $d = 0,034 \text{ m}$ bo'lgan gorizontl truba yuzasida plenkaning laminar oqimida agar issiqlik oqimining zichligi

$q = 5,8 \cdot 10^4 \text{ Vt} / \text{m}^2$. Bug' bosimi $p_n = 1,013 \text{ bar}$ bo'lsa, plenkali kondensasiyada to'yingan quruq suv bug'i damining qanday haroratini ta'minlash kerak?

Javob: $\Delta T = 3,9 \text{ }^\circ\text{C}$.

2.31-masala. Katta hajmdagi suv yuzasining harorati $200 \text{ }^\circ\text{C}$ bo'lgan bug'latgich trubkalarida qaynamoqda. Suv bosimi $1,255 \text{ MPa}$ ga teng. Trubalarning tashqi diametri 40 mm , uzunligi $1,5 \text{ m}$, trubalar soni 30 dona. Pufakchali qaynashdagi issiqlik berish koeffitsiyenti va trubalardan suvga boradigan issiqlik oqimi topilsin.

Javob: $\alpha = 29306 \text{ Vt} / (\text{m}^2 \cdot \text{ }^\circ\text{K})$; $Q = 1,66 \text{ MVt}$.

2.32-masala. Katta hajmda $1,98 \text{ bar}$ bosim ostida qaynayotgan suvdan 300 kg/s to'yingan quruq suv bug'i olish lozim. Agar yuza harorati $131 \text{ }^\circ\text{C}$ bo'lsa, buning uchun talab etilgan qizish yuzasi maydoni aniqlansin.

Javob: $F = 1,15 \text{ m}^2$.

2.33-masala. Issiqlik oqimining suvning plenkali qaynashida $3,61 \text{ bar}$ bosimda tashqi diametri 30 mm va uzunligi $0,48 \text{ m}$ bo'lgan vertikal truba yuzasidagi zichligi aniqlansin. Yuza harorati $155 \text{ }^\circ\text{C}$. Agar truba gorizontall joylashtirilsa, issiqlik berish koeffitsiyenti qanchaga o'zgardi?

Javob: $q = 4297 \text{ Vt} / \text{m}^2$; issiqlik berish koeffitsiyenti 2 barobar kattalashadi.

2.4. Nurlanish orqali issiqlik almashinuv

Issiqlik nurlanishi (radiatsion issiqlik almashinuv) – tabiatda issiqlik tashish, ko'chirish usuli bo'lib, u energiyasi modda bilan o'zaro ta'sir oqibatida issiqlikka o'tadigan elektromagnit to'lqinlar tarqalishi natijasida amalga oshiriladi. Radiatsion issiqlik almashinuvi energiyaning ikki marta o'zgarishi bilan bog'liq: dastlab jismning ichki energiyasi elektromagnit nurlanish energiyasiga aylanadi, shundan so'ng, energiya makonda elektromagnit to'lqinlari yordamida ko'chirilganidan keyin, nurli energiyaning boshqa jism ichki energiyasiga ikkinchi marta aylanishi ro'y beradi. Moddaning issiqlik nurlanishi jism haroratiga bog'liq (moddaning isiganlik darajasiga).

Jismga tushayotgan issiqlik nurlanishi energiyasi jism tomonidan yutilishi, unda aks ettirilishi, yoki u orqali o'tib ketishi mumkin. Unga tushgan nurli energiyani to'liq yutadigan jism mutlaq qora jism (MQJ)

deb ataladi. Qayd etish lozimki, ushbu haroratda MQJ mumkin maksimal miqdordagi energiyani yutadi va tarqatadi.

Jismning o'z nurlanish oqimi zichligiga uning nur chiqarish imkoniyati deb aytiladi. Bu nurlanish parametri to'liqlar uzunligining elementar uchastkasi $d\lambda$ me'yorida o'z nurlanish oqimining spektral zichligi yoki jismning spektral nur tarqatish imkoniyati deb nomlanadi. MQJning nur tarqatish imkoniyati haroratga bog'liq ravishda Stefan-Bolsman qonuniga bo'ysunadi:

$$E_0 = \sigma_0 \cdot T^4 = c_0 \cdot \left[\frac{T}{100}\right]^4, \quad (2.31)$$

bu yerda $\sigma_0 = 5,67 \cdot 10^{-8} \text{ Vt} / (\text{m}^2 \cdot \text{°K}^4)$ – Stefan - Bolsman doimiysi;

$C_0 = 5,67 \text{ Vt} / (\text{m}^2 \cdot \text{°K}^4)$ – mutlaq qora jismning nurlanish koeffitsiyenti;

T – mutlaq qora jism yuzasining harorati, °K.

Tabiatda mutlaq qora jismlarning o'zi mavjud emas. Nurlanish spektri mutlaq qora jism spektriga o'xshash bo'lgan hamda nurlanish oqimining spektral zichligi (E_λ) mutlaq qora jism spektral zichligi ($E_{0,\lambda}$) dan bir xil ulush ε_λ ni tashkil etgan jism kulrang jism deb nomlanadi.

$$\frac{E_\lambda}{E_{0,\lambda}} = \varepsilon_\lambda = \text{const}, \quad (2.32)$$

bu yerda ε_λ – spektral qoralik darajasi.

So'nggi ifoda integratsiyalanganidan keyin butun nurlanish spektri bo'yicha ($0 \leq \lambda \leq \infty$) quyidagini olamiz

$$\frac{E}{E_0} = \varepsilon_\lambda, \quad (2.33)$$

bu yerda E – kulrang jismning nur chiqarish imkoniyati;

E_0 – MQJning nur chiqarish imkoniyati;

ε – kulrang jism qoraligining integral darajasi yoki qoralik darajasi.

Qoralik darajasi – jismning fizik xossalari, uning harorati va g'adirbudurligiga bog'liq ravishda eksperimentlar (tajribalar) yordamida aniqlanadigan kattalik, ma'lumotnomada keltirilgan [7,8].

Kulrang jismning o'z nurlanish oqimi zichligini hisob-kitob qilish (nur tarqatish imkoniyati) uchun mo'ljallangan ifoda:

$$E = \varepsilon \cdot E_0 = \varepsilon \cdot \sigma_0 \cdot T^4 = \varepsilon \cdot c_0 \cdot \left[\frac{T}{100}\right]^4 = c \cdot \left[\frac{T}{100}\right]^4, \quad (2.34)$$

bu yerda $c = \varepsilon \cdot c_0$ – kulrang jismning nurlanish koeffitsiyenti, $Vt / (m^2 \cdot ^\circ K^4)$;

T – jism harorati, $^\circ K$.

Nur o‘tkazadigan shaffof muhit bilan ajratilgan kulrang yuzalardan tashkil topgan yopiq tizimdagi radiatsion issiqlik almashinuvining hisob-kitobi bo‘yicha nazariy qoidalar ilmiy adabiyotlarda batafsil keltirilgan [7,8].

Ikki kulrang yuzadan iborat bo‘lib, diatermik muhit bilan ajratilgan yopiq tizimning natijaviy nurlanish oqimi quyidagi formula bo‘yicha hisoblab topiladi:

$$Q_{w,1} = \varepsilon_{kelt} \cdot \sigma_0 \cdot (T_2^4 - T_1^4) \cdot \varphi_{21} \cdot F_2, \quad (2.35)$$

yoki:

$$Q_{w,1} = c_0 \cdot \left(\left[\frac{T_2}{100} \right]^4 - \left[\frac{T_1}{100} \right]^4 \right) \cdot \varphi_{21} \cdot F_2, \quad (2.36)$$

bu yerda T – issiqlik almashinuvining mutlaq harorat yuzalari, $^\circ K$;

F – issiqlik almashinish yuzasi maydoni, m^2 ;

φ_{12} va φ_{21} – mos ravishda birinchi jismdan ikkinchisiga va ikkinchi jismdan birinchisiga burchak nurlanish koeffitsiyentlari;

ε_{kelt} – ikki jismdan iborat tizimdagi keltirilgan qoralik darajasi;

$c_{kelt} = \sigma_0 \cdot \varepsilon_{kelt}$ – ikki jismdan iborat tizimda keltirilgan nurlanish koeffitsiyenti.

Ikki kulrang jismdan iborat bo‘lgan radiatsion issiqlik almashinuvining yopiq tizimidagi keltirilgan qoralik darajasi va keltirilgan nurlanish koeffitsiyenti quyidagi formulalar bo‘yicha hisoblab topiladi:

$$\varepsilon_{kelt} = \frac{1}{1 + \left(\frac{1}{\varepsilon_1} - 1 \right) \cdot \varphi_{12} + \left(\frac{1}{\varepsilon_2} - 1 \right) \cdot \varphi_{21}}; \quad (2.37)$$

$$c_{kelt} = \varepsilon_{kelt} \cdot c_0 = \frac{1}{\frac{1}{c_0} + \left(\frac{1}{c_1} - \frac{1}{c_0} \right) \cdot \varphi_{12} + \left(\frac{1}{c_2} - \frac{1}{c_0} \right) \cdot \varphi_{21}}; \quad (2.38)$$

bu yerda $c_1 = \varepsilon_1 \cdot c_0$ va $c_2 = \varepsilon_2 \cdot c_0$.

Ikki yuzadan tashkil topgan tizimning nurlanishining burchak koeffitsiyentlarini burchak koeffitsiyentlari xossaligidan foydalanib topish quyay:

a) yopiqlik xossasi

$$\sum_{k=1}^n \varphi_{ik} = 1; \quad (2.39)$$

b) birgalik (o'xshashlik) xossasi

$$\varphi_{ik} \cdot F_i = \varphi_{ki} \cdot F_k; \quad (2.40)$$

c) qavariqsizlik xossasi (yassi va qavariq yuzalar uchun)

$$\varphi_{ii} = 0. \quad (2.41)$$

Ikki jismdan iborat bo'lgan yopiq radiatsion issiqlik almashinuv tizimi uchun quyidagi tenglama to'g'ri:

$$Q_{w,2} = -Q_{w,1}. \quad (2.42)$$

2.34-masala. Ikki trubadan iborat bo'lgan tizimning keltirilgan qoralik darajasi aniqlansin, bunda tashqi diametri $d_1 = 90$ mm bo'lgan bir truba ichki diametri $d_2 = 180$ mm bo'lgan boshqa trubaning ichida joylashgan. Trubalarning qoralik darajasi bir xil va 0,75 ga teng.

Yechim: Ichki trubaning tashqi yuzasini F_1 , tashqi trubaning ichki yuzasini esa - F_2 orqali belgilaymiz. Keltirilgan qoralik darajasini quyidagi formula bo'yicha topamiz:

$$\varepsilon_{kelt} = \frac{1}{1 + \left(\frac{1}{\varepsilon_1} - 1\right) \cdot \varphi_{12} + \left(\frac{1}{\varepsilon_2} - 1\right) \cdot \varphi_{21}}$$

Ichki truba uchun burchak koeffitsiyenti $\varphi_{12} = 1$. Tashqi truba uchun nurlanishning burchak koeffitsiyenti f_{21} ni quyidagi formula bo'yicha hisoblab topamiz:

$$\varphi_{21} = \varphi_{12} \cdot \frac{F_1}{F_2} = \frac{d_1}{d_2} = \frac{90}{180} = 0,5;$$

$$F_1 = \pi \cdot d_1 \cdot \ell, \quad F_2 = \pi \cdot d_2 \cdot \ell;$$

$$\varepsilon_{kelt} = \frac{1}{1 + \left(\frac{1}{0,75} - 1\right) \cdot 1 + \left(\frac{1}{0,75} - 1\right) \cdot 0,5} = 0,667$$

Javob: $\varepsilon_{kelt} = 0,667$.

2.35-masala. Ikki yassi yuza issiqlik almashinuvidagi nurlanish orqali chiqadigan natijaviy issiqlik oqimining zichligi aniqlansin, bunda bir yuza harorati 1000 °C, uning qoralik darajasi 0,7 va boshqa yuza harorati 800 °C, uning qoralik darajasi esa 0,5.

Yechim: Nurlanish orqali chiqadigan natijaviy issiqlik oqimining zichligi quyidagi formula bo'yicha aniqlanadi:

$$q_{w2} = \varepsilon_{kelt} \cdot \sigma_0 \cdot (T_2^4 - T_1^4)$$

Keltirilgan qoralik darajasi

$$\varepsilon_{kelt} = \frac{1}{1 + \left(\frac{1}{\varepsilon_1} - 1\right) \cdot \varphi_{12} + \left(\frac{1}{\varepsilon_2} - 1\right) \cdot \varphi_{21}}$$

Yassi yuzalar uchun $\varphi_{21} = \varphi_{12} = 1$.

$$\varepsilon_{kelt} = \frac{1}{\frac{1}{\varepsilon_1} + \frac{1}{\varepsilon_2} - 1} = \frac{1}{\frac{1}{0,7} + \frac{1}{0,5} - 1} \approx 0,4118;$$

$$q_{w2} = 0,4118 \cdot 5,67 \cdot 10^{-8} \cdot [(1000 + 273)^4 - (800 + 273)^4] = 30366,75 \text{ Vt} / \text{m}^2.$$

Javob: $q_{w2} = 30366,75 \text{ Vt} / \text{m}^2$.

2.36-masala. Agar devor harorati 120 °C, havo harorati esa 40 °C ga teng bo'lsa, bir soatda qozon obmurovkasining 1 m vertikal yuzasi qancha issiqlik yo'qotadi? Bunda konvektiv issiqlik berish koeffitsiyenti 5,5 Vt / (m² · °K) ga teng. Qoralik darajasi obmurovki kotla 0,82.

Yechim: Nurlanish bilan issiqlik oqimining zichligi

$$q_{nurl} = \varepsilon_{kelt} \cdot \sigma_0 \cdot (T_2^4 - T_1^4)$$

Nurlanish burchak koeffitsiyentlari xossalaridan foydalanamiz:

$$\varepsilon_{kelt} = \varepsilon_1, \text{ chunki } F_1 \ll F_2;$$

$$q_1 = 0,82 \cdot 5,67 \cdot 10^{-8} (393^4 - 313^4) = 662,84 \text{ Vt} / \text{m}^2.$$

Konveksiya issiqlik oqimining zichligi

$$q_k = \alpha \cdot \Delta T = 5,5 \cdot (393 - 313) = 440 \text{ Vt} / \text{m}^2.$$

Konveksiya va nurlanish issiqlik oqimining umumiy zichligi

$$q = q_l + q_k = 662,84 + 440 = 1102,84 \text{ Vt/m}^2.$$

Obmurovkaning 1 m² yuzasi bir soat davomida quyidagicha issiqlik yo'qotadi:

$$Q_\tau = Q \cdot \tau = q \cdot F \cdot \tau = 1102,84 \cdot 1 \cdot 3600 = 3,97 \text{ MJ}.$$

Javob: $Q_\tau = 3,97 \text{ MJ}$.

2.37-masala. Agar tashqi diametri 0,1 m bo'lgan quvur bir tarafi 0,5 m bo'lgan g'isht kvadrat kanal markazidan o'tsa, tizimning keltirilgan qoralik darajasi aniqlansin. Trubaning qoralik darajasi 0,72. Kanal devorlari qoralik darajasi 0,85.

Javob: $\varepsilon_{\text{kelt}} = 0,706$.

2.38-masala. Katta hajmli xonadan izolyatsiyalanmagan po'lat truba o'tgan bo'lib, u bo'ylab qaynoq suv oqib o'tadi. Trubaning tashqi diametri 150 mm. Truba tashqi devorining harorati 170 °C. Xona devorlari harorati 20 °C. Trubaning po'lat yuzasi uchun nurlanish koeffitsiyenti 4,5 Vt / (m² · °K⁴). Bir pogon metr trubadan nurlanish orqali yo'qotiladigan issiqlik miqdori aniqlansin.

Javob: $q_r = 660,42 \text{ Vt / m}$.

2.39-masala. Po'lat yombi bo'lagi elektropech ichida qizdiriladi. Pech ichki yuzasining harorati 800 °C, qoralik darajasi 0,82. Brusok yuzasining harorati 350 °C, qoralik darajasi 0,65. Zagotovka pech podida yotadi. Brusokning nur tarqatish maydoni pech nur tarqatish maydonidan 4 marta kichik. Pech devorlaridan brusok yuzasiga tushadigan natijaviy nur oqimi zichligi aniqlansin.

Javob: $q = 41810 \text{ Vt / m}^2$.

2.40-masala. Agar issiqlik nurlanish zichligi 21000 Vt / m², yuza harorati esa 700 °C bo'lsa, yuzaning qoralik darajasi nimaga teng?

Javob: $\varepsilon = 0,413$.

2.41-masala. Agar truba yuzasining harorati 220 °C, qoralik darajasi 0,85 bo'lsa, tashqi diametri 0,12 m bo'lgan, uzunligi 1 m li bug' o'tkazgichdan nurlanish orqali issiqlik yo'qotishlari aniqlansin. Atrof-muhit harorati 17°C.

Javob: $q_t = 944 \text{ Vt / m}$.

2.42-masala. Mutlaq qora jismning o‘z nurlanish oqimi zichligi qanday haroratda $1 \text{ kVt} / \text{m}^2$ ga teng bo‘ladi?

Javob: $T = 91 \text{ }^\circ\text{C}$.

2.43-masala. Diametri $0,1 \text{ m}$ bo‘lgan bug‘ o‘tkazgich yuzasidan nurlanish orqali issiqlik oqimining zichligi aniqlansin. Harorat stenki paroprovoda $427 \text{ }^\circ\text{C}$, qoralik darajasi $0,9$. Atrof-muhit harorati $27 \text{ }^\circ\text{C}$.

Javob: $q = 11840 \text{ Vt} / \text{m}^2$.

2.44-masala. Agar qattiq jism yuzasi harorati $127 \text{ }^\circ\text{C}$ dan $327 \text{ }^\circ\text{C}$ gacha ko‘tarilsa, uning nurlantirish imkoniyati necha marotaba ortadi.

Javob: 5 marotaba.

2.5. Issiqlik almashgich apparatlari

Rekuperativ issiqlik almashgichning issiqlik hisobi uchun ikkita asosiy tenglamadan foydalanadilar – issiqlik muvozanati tenglamasi va issiqlik uzatish tenglamasi. Issiqlik almashinish apparatidagi issiqlik yo‘qotilishlarini hisobga olmaganda issiqlik muvozanatining tenglamasi quyidagi ko‘rinishga ega:

$$Q_1 = Q_2, \quad (2.43)$$

bu yerda Q_1 – qaynoq issiqlik tashuvchi tomonidan vaqt birligi davomida beriladigan issiqlik miqdori, Vt ;

Q_2 – sovuq issiqlik tashuvchi tomonidan vaqt birligi davomida olinadigan issiqlik miqdori, Vt .

Yoyilgan ko‘rinishda issiqlik muvozanatining tenglamasini quyidagi ko‘rinishda yozib olish mumkin:

a) bir fazali issiqlik tashuvchilar uchun

$$Q = G_1 \cdot c_{p1} \cdot (t'_1 - t''_1) = G_2 \cdot c_{p2} \cdot (t''_2 - t'_2); \quad (2.44)$$

b) qaynoq issiqlik tashuvchining agregat holati o‘zgarishida (qaynoq issiqlik tashuvchi – quruq to‘yingan suv bug‘i)

$$Q = G_1 \cdot r_1 = G_2 \cdot c_{p2} \cdot (t''_2 - t'_2); \quad (2.45)$$

bu yerda G_1 va G_2 – qaynoq va sovuq issiqlik tashuvchilarning yalpi (massasiga ko‘ra) sarflari, kg / ik ;

c_{p1} va c_{p2} – qaynoq va sovuq issiqlik tashuvchilarning solishtirma izobarali yalpi issiqlik sig‘imlari, $J / (kg \cdot ^\circ K)$;

t'_1 va t''_1 – qaynoq issiqlik tashuvchining issiqlik almashgichga kirish va undan chiqishdagi harorati, $^\circ C$;

t'_2 va t''_2 – issiqlik almashgichga kirish va chiqish joyidagi sovuq holdagi issiqlik tashuvchi harorati, $^\circ C$.

Issiqlik tashuvchilarning sarflari uzilmaslik yoki yaxlitlik tenglamasiga ko‘ra hisoblab topiladi:

$$G = \rho \cdot \bar{w} \cdot f, \quad (2.46)$$

bu yerda ρ – issiqlik tashuvchi zichligi, kg / m^3 ;

\bar{w} – issiqlik tashuvchining o‘rtacha tezligi, m / i ;

f – issiqlik tashuvchi o‘tishi uchun kanal ko‘ndalang kesimi maydoni, m^2 .

O‘rtacha haroratli issiqlik tashuvchining zichligi va solishtirma issiqlik sig‘imi ma‘lumotnoma [9,14] bo‘yicha topiladi:

$$t = \frac{t' - t''}{2}, \quad (2.47)$$

bu yerda t' va t'' – issiqlik almashuv apparatiga kirish va undan chiqishdagi issiqlik tashuvchi harorati, $^\circ C$.

Agar masala shartiga ko‘ra issiqlik almashgich apparati chiqishida issiqlik tashuvchining harorati berilmagan bo‘lib, balki aniqlanishi talab etilsa, izchil (qadam-baqadam) yaqinlashishlar uslubi qo‘llanadi. Masalan, issiqlik almashgichga kirishdagi qaynoq issiqlik tashuvchining harorati berilgan t'_1 , issiqlik almashuv apparati chiqishidagi ana shu issiqlik tashuvchi haroratini t''_1 esa aniqlash talab etiladi. Buning uchun ma‘lumotnomadan [9,14] zichlik va solishtirma issiqlik sig‘imi c_{p1} ni kirishdagi haroratga t'_1 ko‘ra topamiz.

So‘ng issiqlik muvozanati tenglamasidan chiqishdagi issiqlik tashuvchi haroratini aniqlaymiz:

$$t''_1 = t'_1 - \frac{Q}{G_1 \cdot c_{p1}}. \quad (2.48)$$

t''_1 ni bilib, qaynoq issiqlik tashuvchi o‘rtacha haroratini hisoblab topamiz va ρ va c_{p1} qiymatlariga aniqlik kiritamiz. Agar zichlik va

solishtirma issiqlik sig'iminin yangi topilgan qiymatlari orasidagi farq 5% dan kichik bo'lsa, hisob-kitob tugallanadi, aks holda issiqlik muvozanati tenglamasidan harorat t''_1 ga yana bir marta aniqlik kiritilib, ma'lumot jadvallaridan ρ va c_{p1} qiymatlarini topish talab etiladi.

Issiqlik muvozanatining bir fazali issiqlik tashuvchilar uchun tenglamasini quyidagi ko'rinishda yozib olish mumkin:

$$W_1 \cdot \delta t_1 = W_2 \cdot \delta t_2 \text{ yoki } \delta t_2 / \delta t_1 = W_1 / W_2, \quad (2.49)$$

bu yerda $W_1 = G_1 \cdot c_{p1}$ va $W_2 = G_2 \cdot c_{p2}$ – qaynoq va sovuq issiqlik tashuvchilarning sarf issiqlik sig'implari (suv ekvivalentlari);

$\delta t_1 = (t'_1 - t''_1)$ va $\delta t_2 = (t''_2 - t'_2)$ – qaynoq va sovuq issiqlik tashuvchilarning issiqlik almashgich apparatidagi harorat o'zgarishi.

Issiqlik almashinuv yuzasi bo'ylab issiqlik tashuvchilar harorati eksponensial qonun asosida o'zgaradi (2.2, a – rasm va 2.2, b - rasm). Bunda suv ekvivalentlari va issiqlik almashinuv yuzasi bo'ylab harorat o'zgarishlari o'rtasidagi bog'liqlik teskari proporsional bo'ladi:

agar $W_1 > W_2$ bo'lsa, unda $\delta t_1 < \delta t_2$;

agar $W_1 < W_2$ bo'lsa, unda $\delta t_1 > \delta t_2$.

Issiqlik tashuvchilar (2.2, b-rasm) oqimga qarshi sxema bo'yicha harakatlanganida, issiqlik tashuvchilar haroratining o'zgarish egriliklari bo'rtligi katta suv ekvivalenti, ya'ni harorati kamroq o'zgaradigan issiqlik tashuvchi tomonga qaratilgan bo'ladi.

Agar isituvchi issiqlik tashuvchi bo'lib to'yingan suv bug'i kelsa, u holda issiqlik uzatish jarayonida uning harorati o'zgarmaydi va ushbu bosimdagi to'yinish haroratiga teng bo'ladi:

$$t'_1 = t''_1 = t_n. \quad (2.50)$$

Rekuperativ issiqlik almashinish apparatida issiqlik uzatish tenglamasi quyidagi ko'rinishga ega:

$$Q = k \cdot \overline{\Delta t} \cdot F, \quad (2.51)$$

bu yerda k – issiqlik uzatish koeffitsiyenti, $\text{Wt} / (\text{m} \cdot ^\circ\text{K})$;

$\overline{\Delta t}$ – issiq va sovuq issiqlik tashuvchilar orasidagi o'rtacha haroratlar farqi (o'rtacha harorat naponi), $^\circ\text{C}$;

F – issiqlik almashinish yuzasi maydoni, m²;

r – bug‘ hosil bo‘lishining yashirin issiqligi, J / kg.

Issiqlik uzatish koeffitsiyenti yassi devor uchun issiqlik uzatish formulalari bo‘yicha hisoblab topiladi, chunki issiqlik almashtirgichlar trubkalari devori juda yupqa bo‘ladi [9,14]

$$k = \frac{1}{\frac{1}{\alpha_1} + \frac{\delta}{\lambda} + \frac{1}{\alpha_2}}, \quad (2.52)$$

bu yerda $\delta = 0,5 \cdot (d_{\text{tash}} - d_{\text{ich}})$ – truba devorining qalinligi, m;

λ – devorning issiqlik o‘tkazuvchanlik koeffitsiyenti, Wt / (m · °K);

α_1 va α_2 – qaynoq issiqlik tashuvchidan devorga va devordan sovuq issiqlik tashuvchiga issiqlik berish koeffitsiyentlari, Wt / (m² · °K).

Issiqlik berish koeffitsiyentlari kriterial formulalar bo‘yicha hisoblab topiladi.

Issiqlik tashuvchilarning to‘g‘ri oqadigan va qarama-qarshi oqadigan harakatlanish sxemalari uchun o‘rtacha haroratlari farqi quyidagi formulalarga ko‘ra hisoblab topiladi:

$$\overline{\Delta t_a} = \frac{\Delta t_{\text{max}} + \Delta t_{\text{min}}}{2}, \text{ agar } \Delta t_{\text{max}} / \Delta t_{\text{min}} \leq 2 \quad (2.53)$$

yoki

$$\overline{\Delta t_e} = \frac{\Delta t_{\text{max}} - \Delta t_{\text{min}}}{h \frac{\Delta t_{\text{max}}}{\Delta t_{\text{min}}}}, \text{ agar } \Delta t_{\text{max}} / \Delta t_{\text{min}} > 2 \quad (2.54)$$

bu yerda Δt_{max} va Δt_{min} – issiqlik tashuvchilar haroratidagi maksimal va minimal farqlar (qar. 2.2., a - rasm va 2.2., b - rasm);

Δt_a – o‘rtacha arifmetik haroratlar farqi;

Δt_{log} – o‘rtacha logarifmik haroratlar farqi.

Issiqlik tashuvchilarning murakkab harakatlanishida o‘rtacha harorat farqining hisob-kitobida oqimga qarshi harakat uchun harorat grafigi $t = f(F)$ qurilib, murakkab oqishda issiqlik almashinuvining xususiyatlarini hisobga olgan $\epsilon_{\Delta t}$ tuzatish koeffitsiyentiga ko‘paytiradilar. Bunda, agar bu narsa oldindan berilmagan bo‘lsa, talaba mustaqil ravishda

[7,8,14] ilovada keltirilgan issiqlik tashuvchilarning kesishma yoki murakkab harakatlanishi sxemalaridan birini qabul qilib, rasmga ko'ra $\varepsilon_{\Delta t} = f(P, R)$ ni aniqlaydi.

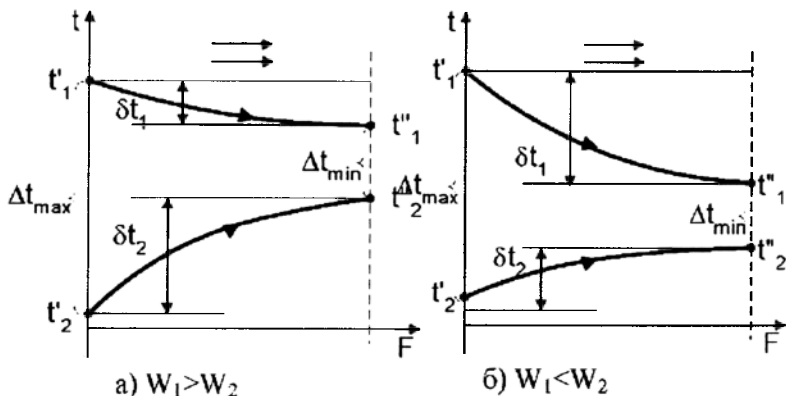

2.2 a-rasm. Issiqlik tashuvchilarning oqim bo'ylab harakatlanish sxemasida ularning suv ekvivalentlari nisbatiga bog'liq ravishda qaynoq va sovuq issiqlik tashuvchilar haroratining issiqlik almashinish yuzasi bo'ylab o'zgarishi

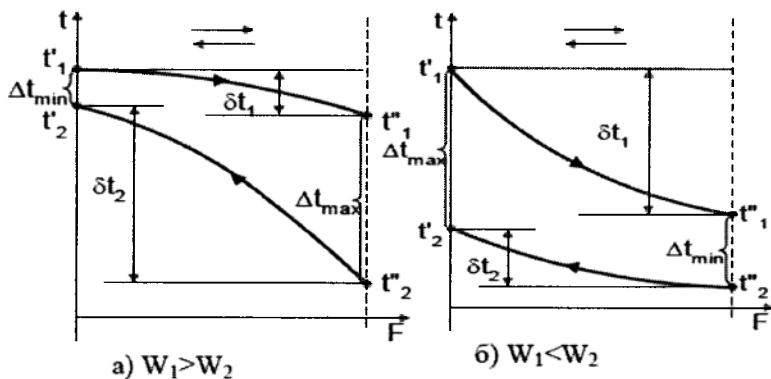

2.2 b-rasm. Issiqlik tashuvchilarning oqimga qarshi harakatlanish sxemasida ularning suv ekvivalentlari nisbatiga bog'liq ravishda qaynoq va sovuq issiqlik tashuvchilar haroratining issiqlik almashinish yuzasi bo'ylab o'zgarishi

2.45-masala. Agar transformator moyining harorati issiqlik almash-tirgichga kirishda $t'_1 = 45\text{ }^\circ\text{C}$, chiqishida $t''_1 = 35\text{ }^\circ\text{C}$, moy sarfi 16000 kg / s bo'lsa, suvli moy sovutgich chiqishidagi sovutuvchi suvning harorati aniqlansin. Sovituvchi suvning kirishdagi harorati $15\text{ }^\circ\text{C}$, suv sarfi 26000 kg / s.

Yechim: Issiqlik muvozanati tenglamasi

$$Q = G_1 \cdot c_{p1} \cdot (t'_1 - t''_1) = G_2 \cdot c_{p2} \cdot (t''_2 - t'_2).$$

Transformator moyining o'rtacha haroratida uning solishtirma issiqlik sig'imi [7,9]

$$t_1 = \frac{t'_1 + t''_1}{2} = \frac{45 + 35}{2} = 40\text{ }^\circ\text{C};$$

$$C_{p1} = 1,788\text{ kJ} / (\text{kg} \cdot ^\circ\text{C}).$$

Issiq tashuvchidan (moy) sovuq tashuvchiga (suv) uzatiladigan issiqlik oqimi Q

$$Q = \frac{16000}{3600} \cdot 1,788 \cdot 10^3 \cdot (45 - 35) = 79467\text{ Vt}.$$

Chiqishdagi sovutuvchi suv haroratining hisobini izchil (oldinma - ketin) yaqinlashishlar uslubi bilan izlaymiz.

$t'_2 = 15\text{ }^\circ\text{C}$ [8,9] $c_{p2} = 4,187\text{ kJ} / (\text{kg} \cdot ^\circ\text{C})$ haroratda suvning solishtirma issiqlik sig'imi.

Issiqlik muvozanati tenglamasidan noma'lum harorat t''_2 ni ifodalaymiz:

$$t''_2 = t'_2 + \frac{Q}{G_2 \cdot c_{p2}};$$

$$t''_2 = 15 + \frac{79467}{\frac{26000}{3600} \cdot 4,187 \cdot 10^3} = 17,63\text{ }^\circ\text{C}.$$

Sovuq issiqlik tashuvchining o'rtacha harorati

$$t_2 = \frac{t'_2 + t''_2}{2} = \frac{15 + 17,63}{2} = 16,31\text{ }^\circ\text{C}.$$

c_{p2} ga aniqlik kiritamiz.

$$t_2 = 16,3 \text{ }^\circ\text{C bo'lganida} \quad c_{p2} = 4,1854 \text{ kJ / (kg} \cdot \text{ }^\circ\text{C)}.$$

Solishtirma issiqlik sig'iminin yangi topilgan s_{r2} qiymatining avvalgi iteratsiya qiymatidan farqi 0,038 % ni tashkil etadi. Shunday qilib, uzil - kesil quyidagiga ega bo'lamiz:

$$t_2 = 16,31 \text{ }^\circ\text{C}; t''_2 = 17,63 \text{ }^\circ\text{C}.$$

Javob: $t''_2 = 17,63 \text{ }^\circ\text{C}$.

2.46-masala. Issiqlik almashinuv apparatida suv 4 kg / ik sarfi bilan 25 °C haroratdan 205 °C gacha haroratga qadar qiziydi. Bunda gazlar 430 °C dan 260 °C gacha soviydilar. Agar teskari oqish, issiqlik uzatish koeffitsiyenti $k = 42 \text{ Vt/(m}^2 \cdot \text{ }^\circ\text{K)}$ bo'lsa, issiqlik almashtirgich to'g'ri oqish va teskari oqish sxemalari bo'yicha ulanganidagi uning yuzasi aniqlansin.

Yechim: Issiqlik tashuvchilarning to'g'ri yo'nalish bo'ylab harakatlanish sxemasi.

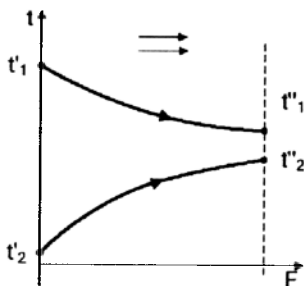

O'rtacha haroratdagi suvning issiqlik sig'imi [7,9]:

$$t_2 = 0,5 (t'_2 + t''_2) = 115 \text{ }^\circ\text{C};$$

$$c_{p2} = 4,2415 \text{ kJ / (kg} \cdot \text{ }^\circ\text{C)}.$$

Suvning gazlardan olgan issiqlik miqdori

$$Q = G_2 \cdot c_{p2} \cdot (t''_2 - t_2) = 4 \cdot 4,2415 \cdot 10^3 \cdot (205 - 25) = 3053,88 \text{ kVt}.$$

Issiqlik almashgichdagi damning maksimal harorati

$$\Delta t_{\max} = t'_1 - t_2 = 430 - 25 = 405 \text{ }^\circ\text{C}.$$

Issiqlik almashgichdagi damning minimal harorati

$$\Delta t_{\min} = t''_1 - t'_2 = 260 - 205 = 55 \text{ }^\circ\text{C}.$$

$$\frac{\Delta t_{\max}}{\Delta t_{\min}} = \frac{405}{55} = 7,36 > 2.$$

O'rtacha logarifmik harorat napori

$$\Delta t_{\log} = \frac{\Delta t_{\max} - \Delta t_{\min}}{\ln \frac{\Delta t_{\max}}{\Delta t_{\min}}} = \frac{405 - 55}{\ln \frac{405}{55}} = 175,3 \text{ } ^\circ\text{C}$$

Issiqlik almashgich yuzasi maydonini issiqlik uzatish tenglamasidan topamiz:

$$Q = k \cdot \overline{\Delta t} \cdot F;$$

$$F_{\text{to'g'ri oqim}} = \frac{Q}{k \cdot \Delta t_{\log}} = \frac{3053,88 \cdot 10^3}{42 \cdot 175,3} = 414,78 \text{ m}^2$$

Oqimga qarshi (teskari) harakatlanish sxemasi

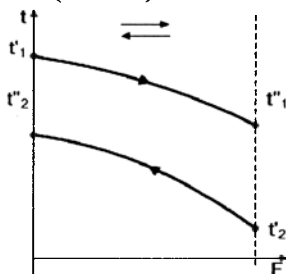

$$\Delta t_{\max} = t''_1 - t'_2 = 260 - 25 = 235 \text{ } ^\circ\text{C};$$

$$\Delta t_{\min} = t'_1 - t''_2 = 430 - 205 = 225 \text{ } ^\circ\text{C};$$

$$\frac{\Delta t_{\max}}{\Delta t_{\min}} = \frac{235}{225} = 1,04 < 2.$$

Damning o'rtacha arifmetik haroratini hisoblab topamiz:

$$\overline{\Delta t}_a = \frac{1}{2} \cdot (\Delta t_{\max} + \Delta t_{\min}) = \frac{1}{2} \cdot (235 + 225) = 230 \text{ } ^\circ\text{C}.$$

$$\frac{Q}{\Delta t_a} = \frac{3053,88 \cdot 10^3}{42 \cdot 230} = 316,13 \text{ m}^2$$

Javob: $F_{\text{to'g'ri oqim}} = 414,78 \text{ m}^2$; $F_{\text{teskari oqim}} = 316,13 \text{ m}^2$.

2.47-masala. Issiqlik almashgichda 0,1 MPa atmosfera bosimida bug' kondensatsiyalanib, kondensat to'yinish haroratida chiqib ketadi. Sovituvchi suv $t'_2 = 20\text{ }^\circ\text{C}$ dan $t''_2 = 95\text{ }^\circ\text{C}$ gacha qiziydi. Issiqlik almashgich yuzasi $F = 8\text{ m}^2$. Issiqlik uzatish koeffitsiyenti $k = 900\text{ Vt}/(\text{m}^2 \cdot \text{ }^\circ\text{K})$ qaynoq issiqlik tashuvchining sarfi aniqlansin.

Yechim: Bunda isituvchi issiqlik tashuvchi bo'lib suv bug'i keladi. Issiqlik muvozanati tenglamasi quyidagi ko'rinishga ega:

$$Q = G_1 \cdot r_1 = G_2 \cdot c_{p2} \cdot (t''_2 - t'_2)$$

$$G_1 = \frac{Q}{r_1}$$

Issiqlik uzatish tenglamasiga ko'ra

$$Q = k \cdot \overline{\Delta t} \cdot F;$$

$$G_1 = \frac{k \cdot \overline{\Delta t} \cdot F}{r_1}.$$

$p_n = 0,1\text{ MPa}$ bo'lganida [8;9] ma'lumotnomaga ko'ra:

$$t_n = 99,63\text{ }^\circ\text{C}; r_1 = 2256,8\text{ kJ}/\text{kg}.$$

Issiqlik tashuvchilarning to'g'ri yo'nalish bo'ylab harakatlanish sxemasi.

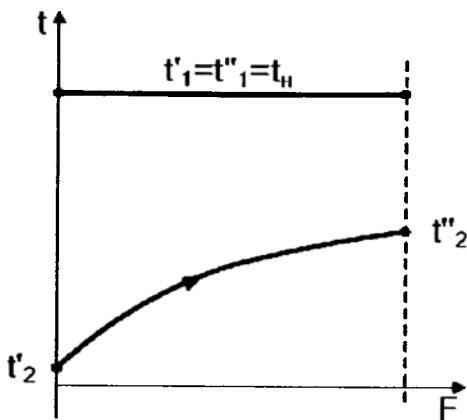

Issqlik almashgichdagi damning maksimal harorati

$$\Delta t_{\max} = t_n - t'_2 = 99,63 - 20 = 79,63 \text{ }^\circ\text{C}.$$

Issqlik almashgichdagi oqimning minimal harorati

$$\Delta t_{\min} = t_n - t''_2 = 99,63 - 95 = 4,63 \text{ }^\circ\text{C}.$$

$$\frac{\Delta t_{\max}}{\Delta t_{\min}} = \frac{79,63}{4,63} = 17,2 > 2,$$

shu sababli oqim(napor)ning o'rtacha logarifmik haroratini hisoblab aniqlaymiz:

$$\Delta t_{\log} = \frac{\Delta t_{\max} - \Delta t_{\min}}{\ln \frac{\Delta t_{\max}}{\Delta t_{\min}}} = \frac{79,63 - 4,63}{\ln \frac{79,63}{4,63}} = 26,36 \text{ }^\circ\text{C}$$

$$G_1 = \frac{900 \cdot 8 \cdot 26,36}{2256,8 \cdot 10^3} = 0,084 \text{ kg/ik}.$$

Javob: $G_1 = 0,084 \text{ kg / ik}$.

2.48-masala. 1. Bunda qaynoq issiqlik tashuvchi bo'lib suv kelgan, uning sarfi esa $0,2 \text{ kg / ik}$ ga teng bo'lsa, haroratlardagi o'rtacha farq va rekuperativ issiqlik almashgichdagi issiqlik tashuvchilarning oqimga qarshi harakatlanish sxemasidagi isitish yuzasi aniqlansin. Kirishdagi suv harorati $110 \text{ }^\circ\text{C}$. Sovuq issiqlik tashuvchi – issiqlik almashtirgichga $t'_2 = 20 \text{ }^\circ\text{C}$ harorat bilan kelib tushayotgan va chiqishda $t''_2 = 70 \text{ }^\circ\text{C}$ haroratga ega bo'lgan havo. Havo sarfi $0,5 \text{ kg/ik}$. Issiqlik uzatish koeffitsiyenti $50 \text{ Vt / (m}^2 \cdot \text{ }^\circ\text{K)}$.

Javob: $t''_1 = 50 \text{ }^\circ\text{C}$; $F = 10 \text{ m}^2$.

2.49-masala. Issiqlik almashtirgichdan to'yingan holatdagi chiqadigan butun bug' isituvchi bug' bosimida kondensatga aylanishi sharti bilan bug'-suv issiqlik almashtirgichdagi suvni isitishga ketadigan bug' sarfi aniqlansin. Issiqlik uzatish koeffitsiyenti $k = 2700 \text{ Vt / (m}^2 \cdot \text{ }^\circ\text{K)}$, agar suv sarfi $G_2 = 2 \text{ m}^3 / \text{daq}$, kirishdagi suv harorati $25 \text{ }^\circ\text{C}$, chiqishdagi harorat $75 \text{ }^\circ\text{C}$ bo'lishi sharti bilan issiqlik almashgichdagi isitish yuzasi maydoni

topilib, u bo‘ylab issiqlik tashuvchilar haroratining o‘zgarishi grafigi sxema tarzida qurilsin. Bug‘ bosimi $p = 0,12$ MPa, quruqlik darajasi $x = 0,98$.

Javob: $G_1 = 3$ kg / ik; $F = 50,5$ m².

2.50-masala. Bug‘lagichda $p_2 = 1$ bar bosimda suv qaynamoqda. Isituvchi bug‘ $p_1 = 20$ bar bosimda kondensatsiyalanib, to‘yinish haroratida chiqib ketadi. Suv sarfi $G_2 = 0,2$ kg / ik. Isituvchi bug‘ sarfi aniqlansin.

Javob: $G_1 = 0,24$ kg / ik.

2.51-masala. MS rusumli moy harorat $t'_1 = 80$ °C bilan moy sovutgichga kelib tushadi va $t''_1 = 40$ °C haroratga qadar sovutiladi. Sovituvchi suvning kirishdagi harorati $t'_2 = 20$ °C. Agar moy va suv sarflari mos ravishda $G_1 = 1 \cdot 10^4$ kg/s va $G_2 = 2,04 \cdot 10^4$ kg / s bo‘lsa, moy sovutgichdan chiqishdagi suv harorati aniqlansin. Atrof muhitga issiqlik yo‘qotilishi hisobga olinmaydi.

Javob: $t''_1 = 30$ °C.

2.52-masala. O‘rtacha haroratlar farqi, isitish yuzasi maydoni va sarf issiqlik sig‘imi har ikkala issiqlik tashuvchilarning oqimga qarshi rekuperativ issiqlik almashgichdagi, agar qaynoq issiqlik tashuvchi (SR moyi) kirishida 90 °C, chiqishida 40 °C haroratga ega bo‘lsa, sovuq (havo) kirishda 25 °C, chiqishda esa 80°C haroratga ega bo‘lsa, aniqlansin. Issiqlik almashgichdagi uzatiladigan issiqlik oqimi, 0,2 MVt. Issiqlik uzatish koeffitsiyenti 70 Vt / (m² · °K)

Javob: $W_1 = 4000$ Vt / °K; $\overline{\Delta t} = 12,5$ °C;

$W_2 = 3636$ Vt / K; $F = 228,6$ m².

2.53-masala. Quvursimon bug‘-suvli issiqlik almashgichda quruq to‘yingan bug‘ $p = 3,61 \cdot 10^5$ Pa bosim bilan trubalarning tashqi yuzasida kondensatsiyalanadi. Trubalar bo‘ylab harakatlanayotgan suv $t'_2 = 20$ °C dan $t''_2 = 90$ °C gacha isiydi. Agar suv sarfi $G_2 = 3$ kg / ik bo‘lsa, ana shu issiqlik almashgichdagi naporning o‘rtacha logarifmik harorati va bug‘ sarfi aniqlansin.

Javob: $\overline{\Delta t} = 69,2$ °C; $G_1 = 0,45$ kg / ik.

TAVSIYA ETILADIGAN ADABIYOTLAR

1. Mirziyoyev SH. M. Erkin va farovon demokratik O‘zbekiston davlatini birgalikda barpo etamiz. Toshkent: O‘zbekiston, 2017. – 29 bet.
2. Mirziyoyev SH. M. Qonun ustuvorligi va inson manfaatlarini ta’minlash yurt taraqqiyoti va xalq farovonligining garovi. Toshkent: O‘zbekiston, 2017. – 47 bet.
3. Mirziyoyev SH. M. Buyuk kelajagimizni mard va olijanob xalqimiz bilan birga quramiz. Toshkent: O‘zbekiston, 2017. – 485 bet.
4. Tarik Al-Shemmeri. Engineering Thermodynamics. Tarik Al-Shemmeri&Ventus Publishing APS, 2010, ISBN 978-87-7681-670-4.
5. Nag P. K., Engineering Thermodynamics. Tata McGraw-Hill Education, India, 2005.
6. Zoxidov R. A., Avezov R. R. Issiqlik texnikasining nazoriy asoslari. O‘quv qo‘llanma. Toshkent: TDTU, 2005.
7. Бухмиров В. В., Щербакова Г. П., Пекунова А. В. Теоретические основы теплотехники в примерах и задачах. Учебное пособие. – Иваново, ИГЭУ, 2013. – 128 с.
8. Александров А.А., Григорьев Б.А. Таблицы теплофизических свойств воды и водяного пара: Справочник. Рек. Гос. службой стандартных справочных данных. ГСССД Р-776-98 - М.: Издательство МЭИ. 1999.-168 с.
9. Коновалов В. И. Техническая термодинамика. Учебник для вузов. - 2005. - 620 с.
10. Рабинович О. М. Сборник задач по технической термодинамике. - М.: Машиностроение, 1974. – 376 с.
11. Tajiyev Yu. D., Ablyalimov O. S. Termodinamika va issiqlik texnikasi. To‘g‘ri termodinamik gaz tsiklini yechish amaliy mashg‘ulotlar o‘tkazish uchun uslubiy ko‘rsatma. Toshkent: TTYMI, 2008. – 17 bet.
12. Tajiyev Yu. D., Ablyalimov O. S., Agapov V. V. Termodinamika va issiqlik texnikasi. Laboratoriya bajarish uchun uslubiy ko‘rsatma. Toshkent: TTYMI, 2008. – 68 bet.
13. Tajiev Yu. D., Termodinamika va issiqlik texnikasi. O‘quv qo‘llanma. Toshkent: ToshTYMI, 2011. – 97 bet.
14. Ablyalimov O. S., Xismatulin M. I. Termodinamika. O‘zbekiston Respublikasi Oliy va o‘rta ta’lim vazirligi tomonidan Oliy o‘quv yurtlari noisliqlikenergetika bakalavriat ta’lim yo‘nalishi talabalari uchun darslik sifatida tavsiya etilgan. Toshkent: Ijod-Press nashriyoti, 2019. – 416 bet.

ILOVA

Suv va suv bug'i teplofizik ko'rsatkichlari bo'yicha ma'lumotlari

1-jadval

Suv va suv bug'i termodinamik ko'rsatkichini harorat bo'yicha vaziyatda singdirish

t	p	v'	v''	i'	i''	r	s'	s''	s''-s'
0	6,112·10 ²	0,0010002	206,140	-0,04	2500,9	2500,9	-0,0002	9,1558	9,1559
0,01	6,117·10 ²	0,0010002	205,997	0,00	2500,9	2500,9	0,0000	9,1555	9,1555
1	6,571·10 ²	0,0010001	192,445	4,18	2502,7	2498,6	0,0153	9,1291	9,1138
2	7,060·10 ²	0,0010001	179,764	8,39	2504,6	2496,2	0,0306	9,1027	9,0721
3	7,581·10 ²	0,0010001	168,014	12,60	2506,4	2493,8	0,0459	9,0765	9,0306
4	8,135·10 ²	0,0010001	157,121	16,81	2508,2	2491,4	0,0611	9,0506	8,9895
5	8,726·10 ²	0,0010001	147,017	21,02	2510,1	2489,1	0,0763	9,0249	8,9486
6	9,354·10 ²	0,0010001	137,638	25,22	2511,9	2486,7	0,0913	8,9994	8,9081
7	1,0021·10 ³	0,0010001	128,928	29,43	2513,7	2484,3	0,1064	8,9742	8,8678
8	1,0730·10 ³	0,0010002	120,834	33,63	2515,6	2481,9	0,1213	8,9492	8,8278
9	1,1483·10 ³	0,0010003	113,309	37,82	2517,4	2479,6	0,1362	8,9244	8,7882
10	1,2282·10 ³	0,0010003	106,309	42,02	2519,2	2477,2	0,1511	8,8998	8,7488
11	1,3129·10 ³	0,0010004	99,793	46,22	2521,1	2474,8	0,1659	8,8755	8,7096
12	1,4028·10 ³	0,0010005	93,724	50,41	2522,9	2472,5	0,1806	8,8514	8,6708
13	1,4981·10 ³	0,0010007	88,070	54,60	2524,7	2470,1	0,1953	8,8275	8,6322
14	1,5989·10 ³	0,0010008	82,798	58,79	2526,5	2467,7	0,2099	8,8038	8,5939
15,0	1,7057·10 ³	0,0010009	77,881	62,98	2528,4	2465,4	0,2245	8,7804	8,5559
15,5	1,7615·10 ³	0,0010010	75,547	65,08	2529,3	2464,2	0,2317	8,7687	8,5370
16,0	1,8188·10 ³	0,0010011	73,291	67,17	2530,2	2463,0	0,2390	8,7571	8,5181
16,5	1,8777·10 ³	0,0010012	71,112	69,27	2531,1	2461,8	0,2462	8,7456	8,4993
17,0	1,9383·10 ³	0,0010013	69,006	71,36	2532,0	2460,6	0,2534	8,7341	8,4806
17,5	2,0006·10 ³	0,0010014	66,971	73,45	2532,9	2459,5	0,2607	8,7226	8,4620
18,0	2,0647·10 ³	0,0010015	65,003	75,55	2533,8	2458,3	0,2678	8,7112	8,4434
18,5	2,1305·10 ³	0,0010015	63,100	77,64	2534,7	2457,1	0,2750	8,6999	8,4248
19,0	2,1982·10 ³	0,0010016	61,261	79,73	2535,7	2455,9	0,2822	8,6886	8,4064
19,5	2,2677·10 ³	0,0010017	59,482	81,83	2536,6	2454,7	0,2894	8,6773	8,3880
20,0	2,3392·10 ³	0,0010018	57,761	83,92	2537,5	2453,5	0,2965	8,6661	8,3696
20,5	2,4127·10 ³	0,0010019	56,097	86,01	2538,4	2452,4	0,3036	8,6550	8,3513
21,0	2,4881·10 ³	0,0010021	54,487	88,10	2539,3	2451,2	0,3108	8,6439	8,3331

21,5	2,5656·10 ³	0,0010022	52,930	90,20	2540,2	2450,0	0,3179	8,6328	8,3150
22,0	2,6452·10 ³	0,0010023	51,422	92,29	2541,1	2448,8	0,3250	8,6218	8,2969
22,5	2,7270·10 ³	0,0010024	49,964	94,38	2542,0	2447,6	0,3320	8,6109	8,2788
23,0	2,8109·10 ³	0,0010025	48,552	96,47	2542,9	2446,4	0,3391	8,6000	8,2609
23,5	2,8971·10 ³	0,0010026	47,186	98,56	2543,8	2445,3	0,3462	8,5891	8,2429
24,0	2,9856·10 ³	0,0010028	45,863	100,66	2544,7	2444,1	0,3532	8,5783	8,2251
24,5	3,0765·10 ³	0,0010029	44,582	102,75	2545,6	2442,9	0,3602	8,5675	8,2073
25,0	3,1697·10 ³	0,0010030	43,341	104,84	2546,5	2441,7	0,3673	8,5568	8,1895
25,5	3,2655·10 ³	0,0010031	42,140	106,93	2547,4	2440,5	0,3743	8,5461	8,1719
26,0	3,3637·10 ³	0,0010033	40,977	109,02	2548,4	2439,3	0,3813	8,5355	8,1542
26,5	3,4645·10 ³	0,0010034	39,850	111,11	2549,3	2438,1	0,3882	8,5249	8,1367

1-jadval (davomi)

t	p	v	v [~]	i	i [~]	r	s	s [~]	s [~] -s
27,0	3,5679·10 ³	0,0010035	38,758	113,20	2550,2	2437,0	0,3952	8,5144	8,1192
27,5	3,6740·10 ³	0,0010037	37,700	115,29	2551,1	2435,8	0,4022	8,5039	8,1017
28,0	3,7828·10 ³	0,0010038	36,675	117,38	2552,0	2434,6	0,4091	8,4934	8,0843
28,5	3,8944·10 ³	0,0010040	35,682	119,47	2552,9	2433,4	0,4161	8,4830	8,0670
29,0	4,0089·10 ³	0,0010041	34,719	121,56	2553,8	2432,2	0,4230	8,4727	8,0497
29,5	4,1263·10 ³	0,0010043	33,786	123,65	2554,7	2431,0	0,4299	8,4624	8,0325
30,0	4,2467·10 ³	0,0010044	32,882	125,75	2555,6	2429,8	0,4368	8,4521	8,0153
30,5	4,3701·10 ³	0,0010046	32,005	127,84	2556,5	2428,7	0,4437	8,4419	7,9982
31,0	4,4966·10 ³	0,0010047	31,154	129,93	2557,4	2427,5	0,4506	8,4317	7,9812
31,5	4,6263·10 ³	0,0010049	30,329	132,02	2558,3	2426,3	0,4574	8,4216	7,9642
32,0	4,7592·10 ³	0,0010050	29,529	134,11	2559,2	2425,1	0,4643	8,4115	7,9472
32,5	4,8955·10 ³	0,0010052	28,754	136,20	2560,1	2423,9	0,4711	8,4014	7,9303
33,0	5,0351·10 ³	0,0010054	28,001	138,29	2561,0	2422,7	0,4780	8,3914	7,9135
33,5	5,1781·10 ³	0,0010055	27,271	140,38	2561,9	2421,5	0,4848	8,3815	7,8967
34,0	5,3247·10 ³	0,0010057	26,562	142,47	2562,8	2420,3	0,4916	8,3715	7,8800
34,5	5,4748·10 ³	0,0010059	25,875	144,56	2563,7	2419,1	0,4984	8,3617	7,8633
35,0	5,6286·10 ³	0,0010060	25,208	146,64	2564,6	2417,9	0,5052	8,3518	7,8467
36,0	5,9475·10 ³	0,0010064	23,932	150,82	2566,4	2415,6	0,5187	8,3323	7,8136
37,0	6,2818·10 ³	0,0010068	22,729	155,00	2568,2	2413,2	0,5322	8,3129	7,7807
38,0	6,6324·10 ³	0,0010071	21,595	159,18	2570,0	2410,8	0,5457	8,2936	7,7480
39	6,9997·10 ³	0,0010075	20,526	163,36	2571,8	2408,4	0,5591	8,2746	7,7155
40	7,3844·10 ³	0,0010079	19,517	167,54	2573,5	2406,0	0,5724	8,2557	7,6832
41	7,7873·10 ³	0,0010083	18,565	171,72	2575,3	2403,6	0,5858	8,2369	7,6512
42	8,2090·10 ³	0,0010087	17,665	175,90	2577,1	2401,2	0,5990	8,2183	7,6193
43	8,6503·10 ³	0,0010091	16,816	180,08	2578,9	2398,8	0,6123	8,1999	7,5876
44	9,1118·10 ³	0,0010095	16,013	184,26	2580,7	2396,4	0,6255	8,1816	7,5561
45	9,5944·10 ³	0,0010099	15,253	188,44	2582,5	2394,0	0,6386	8,1634	7,5248
46	1,0099·10 ⁴	0,0010103	14,535	192,62	2584,2	2391,6	0,6517	8,1454	7,4937
47	1,0626·10 ⁴	0,0010108	13,856	196,80	2586,0	2389,2	0,6648	8,1276	7,4628

t	p	v'	v''	i'	i''	r	s'	s''	s' - s''
48	1,1176·10 ⁴	0,0010112	13,213	200,98	2587,8	2386,8	0,6778	8,1099	7,4320
49	1,1751·10 ⁴	0,0010117	12,604	205,16	2589,5	2384,4	0,6908	8,0923	7,4015
50	1,2351·10 ⁴	0,0010121	12,028	209,34	2591,3	2382,0	0,7038	8,0749	7,3711
51	1,2977·10 ⁴	0,0010126	11,482	213,52	2593,1	2379,6	0,7167	8,0576	7,3409
52	1,3631·10 ⁴	0,0010131	10,964	217,70	2594,8	2377,1	0,7296	8,0405	7,3109
53	1,4312·10 ⁴	0,0010136	10,473	221,88	2596,6	2374,7	0,7424	8,0235	7,2811
54	1,5022·10 ⁴	0,0010140	10,007	226,06	2598,4	2372,3	0,7552	8,0066	7,2514
55	1,5761·10 ⁴	0,0010145	9,5649	230,24	2600,1	2369,9	0,7680	7,9899	7,2219
56	1,6532·10 ⁴	0,0010150	9,1454	234,42	2601,9	2367,4	0,7807	7,9733	7,1926
57	1,7335·10 ⁴	0,0010155	8,7471	238,61	2603,6	2365,0	0,7934	7,9568	7,1634
58	1,8171·10 ⁴	0,0010161	8,3688	242,79	2605,4	2362,6	0,8060	7,9405	7,1344
59	1,9041·10 ⁴	0,0010166	8,0093	246,97	2607,1	2360,1	0,8186	7,9243	7,1056
60	1,9946·10 ⁴	0,0010171	7,6677	251,15	2608,8	2357,7	0,8312	7,9082	7,0770
61	2,0887·10 ⁴	0,0010176	7,3428	255,34	2610,6	2355,2	0,8438	7,8922	7,0485
62	2,1866·10 ⁴	0,0010182	7,0338	259,52	2612,3	2352,8	0,8563	7,8764	7,0201
63	2,2884·10 ⁴	0,0010187	6,7399	263,71	2614,1	2350,3	0,8687	7,8607	6,9919
64	2,3942·10 ⁴	0,0010193	6,4601	267,89	2615,8	2347,9	0,8811	7,8451	6,9639
65	2,5041·10 ⁴	0,0010199	6,1938	272,08	2617,5	2345,4	0,8935	7,8296	6,9361
66	2,6183·10 ⁴	0,0010204	5,9402	276,27	2619,2	2343,0	0,9059	7,8142	6,9083
67	2,7368·10 ⁴	0,0010210	5,6986	280,45	2621,0	2340,5	0,9182	7,7990	6,8808
68	2,8599·10 ⁴	0,0010216	5,4684	284,64	2622,7	2338,0	0,9305	7,7839	6,8534
69	2,9876·10 ⁴	0,0010222	5,2490	288,83	2624,4	2335,6	0,9428	7,7689	6,8261
70	3,1201·10 ⁴	0,0010228	5,0397	293,02	2626,1	2333,1	0,9550	7,7540	6,7990
71	3,2575·10 ⁴	0,0010234	4,8402	297,21	2627,8	2330,6	0,9672	7,7392	6,7720
72	3,4000·10 ⁴	0,0010240	4,6498	301,40	2629,5	2328,1	0,9793	7,7245	6,7452
73	3,5478·10 ⁴	0,0010246	4,4681	305,59	2631,2	2325,6	0,9915	7,7100	6,7185
74	3,7009·10 ⁴	0,0010252	4,2947	309,78	2632,9	2323,1	1,0035	7,6955	6,6920
75	3,8595·10 ⁴	0,0010258	4,1291	313,97	2634,6	2320,6	1,0156	7,6812	6,6656
76	4,0239·10 ⁴	0,0010265	3,9709	318,17	2636,3	2318,1	1,0276	7,6669	6,6393
77	4,1941·10 ⁴	0,0010271	3,8198	322,36	2638,0	2315,6	1,0396	7,6528	6,6132
78	4,3703·10 ⁴	0,0010277	3,6754	326,56	2639,7	2313,1	1,0516	7,6388	6,5872
79	4,5527·10 ⁴	0,0010284	3,5373	330,75	2641,3	2310,6	1,0635	7,6248	6,5613
80	4,7415·10 ⁴	0,0010290	3,4053	334,95	2643,0	2308,1	1,0754	7,6110	6,5356
81	4,9368·10 ⁴	0,0010297	3,2790	339,15	2644,7	2305,5	1,0873	7,5973	6,5100
82	5,1387·10 ⁴	0,0010304	3,1582	343,34	2646,4	2303,0	1,0991	7,5837	6,4846
83	5,3476·10 ⁴	0,0010310	3,0426	347,54	2648,0	2300,5	1,1109	7,5701	6,4592
84	5,5636·10 ⁴	0,0010317	2,9319	351,74	2649,7	2297,9	1,1227	7,5567	6,4340
85	5,7867·10 ⁴	0,0010324	2,8259	355,95	2651,3	2295,4	1,1344	7,5434	6,4090
86	6,0174·10 ⁴	0,0010331	2,7244	360,15	2653,0	2292,8	1,1461	7,5301	6,3840
87	6,2556·10 ⁴	0,0010338	2,6272	364,35	2654,6	2290,3	1,1578	7,5170	6,3592
88	6,5017·10 ⁴	0,0010345	2,5341	368,56	2656,3	2287,7	1,1694	7,5039	6,3345
89	6,7559·10 ⁴	0,0010352	2,4448	372,76	2657,9	2285,1	1,1811	7,4909	6,3099
90	7,0182·10 ⁴	0,0010359	2,3591	376,97	2659,5	2282,6	1,1927	7,4781	6,2854

t	p	v	v'	i	i'	r	s	s'	s'-s
91	7,2890·10 ⁴	0,0010367	2,2771	381,18	2661,2	2280,0	1,2042	7,4653	6,2611
92	7,5685·10 ⁴	0,0010374	2,1983	385,38	2662,8	2277,4	1,2158	7,4526	6,2368
93	7,8568·10 ⁴	0,0010381	2,1228	389,59	2664,4	2274,8	1,2273	7,4400	6,2127
94	8,1542·10 ⁴	0,0010389	2,0502	393,81	2666,0	2272,2	1,2387	7,4275	6,1887
95	8,4609·10 ⁴	0,0010396	1,9806	398,02	2667,6	2269,6	1,2502	7,4150	6,1648
96	8,7771·10 ⁴	0,0010404	1,9138	402,23	2669,2	2267,0	1,2616	7,4027	6,1411
97	9,1031·10 ⁴	0,0010411	1,8497	406,45	2670,8	2264,4	1,2730	7,3904	6,1174
98	9,4390·10 ⁴	0,0010419	1,7880	410,66	2672,4	2261,7	1,2844	7,3782	6,0938
99	9,7852·10 ⁴	0,0010427	1,7288	414,88	2674,0	2259,1	1,2957	7,3661	6,0704
100	1,0142·10 ⁵	0,0010435	1,6719	419,10	2675,6	2256,5	1,3070	7,3541	6,0471
101	1,0509·10 ⁵	0,0010442	1,6171	423,32	2677,1	2253,8	1,3183	7,3421	6,0238
102	1,0887·10 ⁵	0,0010450	1,5645	427,54	2678,7	2251,2	1,3296	7,3303	6,0007
103	1,1277·10 ⁵	0,0010458	1,5140	431,76	2680,3	2248,5	1,3408	7,3185	5,9777
104	1,1678·10 ⁵	0,0010466	1,4653	435,99	2681,8	2245,9	1,3520	7,3068	5,9548
105	1,2090·10 ⁵	0,0010474	1,4185	440,21	2683,4	2243,2	1,3632	7,2951	5,9320
106	1,2515·10 ⁵	0,0010483	1,3734	444,44	2684,9	2240,5	1,3743	7,2836	5,9092
107	1,2951·10 ⁵	0,0010491	1,3301	448,67	2686,5	2237,8	1,3854	7,2721	5,8866
108	1,3401·10 ⁵	0,0010499	1,2883	452,90	2688,0	2235,1	1,3965	7,2607	5,8641
109	1,3863·10 ⁵	0,0010507	1,2481	457,13	2689,5	2232,4	1,4076	7,2493	5,8417
110	1,4338·10 ⁵	0,0010516	1,2094	461,36	2691,1	2229,7	1,4187	7,2380	5,8194
111	1,4826·10 ⁵	0,0010524	1,1721	465,60	2692,6	2227,0	1,4297	7,2268	5,7972
112	1,5328·10 ⁵	0,0010533	1,1362	469,83	2694,1	2224,3	1,4407	7,2157	5,7750
113	1,5843·10 ⁵	0,0010541	1,1015	474,07	2695,6	2221,5	1,4517	7,2047	5,7530
114	1,6373·10 ⁵	0,0010550	1,0681	478,31	2697,1	2218,8	1,4626	7,1937	5,7310
115	1,6918·10 ⁵	0,0010559	1,0359	482,55	2698,6	2216,0	1,4735	7,1827	5,7092
116	1,7477·10 ⁵	0,0010568	1,0049	486,80	2700,1	2213,3	1,4844	7,1719	5,6874
117	1,8051·10 ⁵	0,0010576	0,97495	491,0	2701,5	2210,5	1,4953	7,1611	5,6658
118	1,8640·10 ⁵	0,0010585	0,94607	495,3	2703,0	2207,7	1,5062	7,1504	5,6442
119	1,9245·10 ⁵	0,0010594	0,91820	499,5	2704,5	2204,9	1,5170	7,1397	5,6227
120	1,9867·10 ⁵	0,0010603	0,89130	503,8	2705,9	2202,1	1,5278	7,1291	5,6013
121	2,0504·10 ⁵	0,0010612	0,86534	508,0	2707,4	2199,3	1,5386	7,1186	5,5800
122	2,1158·10 ⁵	0,0010622	0,84028	512,3	2708,8	2196,5	1,5494	7,1081	5,5587
123	2,1829·10 ⁵	0,0010631	0,81607	516,5	2710,3	2193,7	1,5601	7,0977	5,5376
124	2,2517·10 ⁵	0,0010640	0,79269	520,8	2711,7	2190,9	1,5708	7,0873	5,5165
125	2,3222·10 ⁵	0,0010649	0,77011	525,1	2713,1	2188,0	1,5815	7,0770	5,4955
126	2,3946·10 ⁵	0,0010659	0,74829	529,3	2714,5	2185,2	1,5922	7,0668	5,4746
127	2,4688·10 ⁵	0,0010668	0,72721	533,6	2715,9	2182,3	1,6028	7,0566	5,4538
128	2,5448·10 ⁵	0,0010678	0,70683	537,9	2717,3	2179,5	1,6134	7,0465	5,4330
129	2,6227·10 ⁵	0,0010687	0,68713	542,1	2718,7	2176,6	1,6240	7,0364	5,4124
130	2,7026·10 ⁵	0,0010697	0,66808	546,4	2720,1	2173,7	1,6346	7,0264	5,3918
131	2,7844·10 ⁵	0,0010707	0,64966	550,7	2721,5	2170,8	1,6452	7,0165	5,3713
132	2,8682·10 ⁵	0,0010717	0,63185	554,9	2722,8	2167,9	1,6557	7,0066	5,3508
133	2,9541·10 ⁵	0,0010727	0,61461	559,2	2724,2	2165,0	1,6662	6,9967	5,3305

t	p	v	v ⁻	i	i ⁻	r	s	s ⁻	s ⁻ - s
134	3,0420·10 ⁵	0,0010736	0,59794	563,5	2725,5	2162,0	1,6767	6,9869	5,3102
135	3,1320·10 ⁵	0,0010747	0,58180	567,8	2726,9	2159,1	1,6872	6,9772	5,2900
136	3,2242·10 ⁵	0,0010757	0,56618	572,0	2728,2	2156,2	1,6977	6,9675	5,2698
137	3,3185·10 ⁵	0,0010767	0,55106	576,3	2729,5	2153,2	1,7081	6,9579	5,2498
138	3,4151·10 ⁵	0,0010777	0,53642	580,6	2730,8	2150,2	1,7185	6,9483	5,2298
139	3,5139·10 ⁵	0,0010787	0,52225	584,9	2732,1	2147,2	1,7289	6,9388	5,2098
140	3,6150·10 ⁵	0,0010798	0,50852	589,2	2733,4	2144,2	1,7393	6,9293	5,1900
141	3,7185·10 ⁵	0,0010808	0,49522	593,5	2734,7	2141,2	1,7496	6,9198	5,1702
142	3,8243·10 ⁵	0,0010819	0,48233	597,8	2736,0	2138,2	1,7600	6,9105	5,1505
143	3,9325·10 ⁵	0,0010829	0,46985	602,1	2737,3	2135,2	1,7703	6,9011	5,1308
144	4,0432·10 ⁵	0,0010840	0,45775	606,4	2738,5	2132,2	1,7806	6,8918	5,1112
145	4,1563·10 ⁵	0,0010850	0,44602	610,7	2739,8	2129,1	1,7909	6,8826	5,0917
146	4,2721·10 ⁵	0,0010861	0,43465	615,0	2741,0	2126,0	1,8011	6,8734	5,0723
147	4,3903·10 ⁵	0,0010872	0,42362	619,3	2742,3	2123,0	1,8114	6,8642	5,0529
148	4,5112·10 ⁵	0,0010883	0,41293	623,6	2743,5	2119,9	1,8216	6,8551	5,0335
149	4,6348·10 ⁵	0,0010894	0,40256	627,9	2744,7	2116,8	1,8318	6,8461	5,0143
150	4,7610·10 ⁵	0,0010905	0,39250	632,3	2745,9	2113,7	1,8420	6,8370	4,9951
151	4,8900·10 ⁵	0,0010916	0,38274	636,6	2747,1	2110,5	1,8521	6,8281	4,9759
152	5,0218·10 ⁵	0,0010927	0,37327	640,9	2748,3	2107,4	1,8623	6,8191	4,9569
153	5,1564·10 ⁵	0,0010939	0,36408	645,2	2749,5	2104,3	1,8724	6,8102	4,9378
154	5,2938·10 ⁵	0,0010950	0,35516	649,5	2750,6	2101,1	1,8825	6,8014	4,9189
155	5,4342·10 ⁵	0,0010962	0,34650	653,9	2751,8	2097,9	1,8926	6,7926	4,9000
156	5,5776·10 ⁵	0,0010973	0,33809	658,2	2752,9	2094,7	1,9027	6,7838	4,8811
157	5,7239·10 ⁵	0,0010985	0,32993	662,5	2754,1	2091,5	1,9127	6,7751	4,8623
158	5,8733·10 ⁵	0,0010996	0,32200	666,9	2755,2	2088,3	1,9228	6,7664	4,8436
159	6,0258·10 ⁵	0,0011008	0,31430	671,2	2756,3	2085,1	1,9328	6,7577	4,8249
160	6,1814·10 ⁵	0,0011020	0,30682	675,6	2757,4	2081,9	1,9428	6,7491	4,8063
161	6,3402·10 ⁵	0,0011032	0,29955	679,9	2758,5	2078,6	1,9528	6,7405	4,7878
162	6,5022·10 ⁵	0,0011044	0,29249	684,3	2759,6	2075,3	1,9627	6,7320	4,7693
163	6,6676·10 ⁵	0,0011056	0,28562	688,6	2760,7	2072,1	1,9727	6,7235	4,7508
164	6,8362·10 ⁵	0,0011068	0,27895	693,0	2761,7	2068,8	1,9826	6,7150	4,7324
165	7,0082·10 ⁵	0,0011080	0,27246	697,3	2762,8	2065,4	1,9926	6,7066	4,7140
166	7,1836·10 ⁵	0,0011093	0,26616	701,7	2763,8	2062,1	2,0025	6,6982	4,6957
167	7,3625·10 ⁵	0,0011105	0,26002	706,1	2764,9	2058,8	2,0123	6,6898	4,6775
168	7,5450·10 ⁵	0,0011117	0,25406	710,5	2765,9	2055,4	2,0222	6,6815	4,6593
169	7,7309·10 ⁵	0,0011130	0,24826	714,8	2766,9	2052,1	2,0321	6,6732	4,6411
170	7,9205·10 ⁵	0,0011143	0,24262	719,2	2767,9	2048,7	2,0419	6,6649	4,6230
171	8,1138·10 ⁵	0,0011155	0,23713	723,6	2768,9	2045,3	2,0518	6,6567	4,6050
172	8,3108·10 ⁵	0,0011168	0,23178	728,0	2769,9	2041,9	2,0616	6,6485	4,5870
173	8,5115·10 ⁵	0,0011181	0,22659	732,4	2770,8	2038,5	2,0714	6,6404	4,5690
174	8,7161·10 ⁵	0,0011194	0,22153	736,8	2771,8	2035,0	2,0811	6,6322	4,5511
175	8,9245·10 ⁵	0,0011207	0,21660	741,2	2772,7	2031,6	2,0909	6,6241	4,5332
176	9,1368·10 ⁵	0,0011220	0,21181	745,6	2773,6	2028,1	2,1007	6,6161	4,5154

t	p	v'	v''	i'	i''	r	s'	s''	s''-s'
177	9,3531·10 ¹	0,0011234	0,20714	750,0	2774,5	2024,6	2,1104	6,6080	4,4976
178	9,5734·10 ¹	0,0011247	0,20260	754,4	2775,4	2021,1	2,1201	6,6000	4,4799
179	9,7978·10 ¹	0,0011260	0,19817	758,8	2776,3	2017,6	2,1298	6,5920	4,4622
180	1,0026·10 ⁶	0,0011274	0,19386	763,2	2777,2	2014,0	2,1395	6,5841	4,4445
181	1,0259·10 ⁶	0,0011288	0,18966	767,6	2778,1	2010,5	2,1492	6,5761	4,4269
182	1,0496·10 ⁶	0,0011301	0,18557	772,0	2778,9	2006,9	2,1589	6,5682	4,4094
183	1,0737·10 ⁶	0,0011315	0,18159	776,5	2779,8	2003,3	2,1685	6,5604	4,3918
184	1,0983·10 ⁶	0,0011329	0,17770	780,9	2780,6	1999,7	2,1782	6,5525	4,3743
185	1,1233·10 ⁶	0,0011343	0,17392	785,3	2781,4	1996,1	2,1878	6,5447	4,3569
186	1,1487·10 ⁶	0,0011357	0,17023	789,8	2782,2	1992,5	2,1974	6,5369	4,3395
187	1,1746·10 ⁶	0,0011371	0,16663	794,2	2783,0	1988,8	2,2070	6,5292	4,3221
188	1,2009·10 ⁶	0,0011386	0,16313	798,7	2783,8	1985,1	2,2166	6,5214	4,3048
189	1,2277·10 ⁶	0,0011400	0,15971	803,1	2784,6	1981,5	2,2262	6,5137	4,2875
190	1,2550·10 ⁶	0,0011414	0,15638	807,6	2785,3	1977,7	2,2358	6,5060	4,2702
191	1,2828·10 ⁶	0,0011429	0,15313	812,0	2786,0	1974,0	2,2453	6,4983	4,2530
192	1,3110·10 ⁶	0,0011444	0,14996	816,5	2786,8	1970,3	2,2549	6,4907	4,2358
193	1,3397·10 ⁶	0,0011459	0,14686	821,0	2787,5	1966,5	2,2644	6,4831	4,2187
194	1,3689·10 ⁶	0,0011473	0,14385	825,4	2788,2	1962,7	2,2739	6,4755	4,2015
195	1,3986·10 ⁶	0,0011488	0,14091	829,9	2788,9	1958,9	2,2834	6,4679	4,1844
196	1,4288·10 ⁶	0,0011504	0,13803	834,4	2789,5	1955,1	2,2929	6,4603	4,1674
197	1,4595·10 ⁶	0,0011519	0,13523	838,9	2790,2	1951,3	2,3024	6,4528	4,1504
198	1,4907·10 ⁶	0,0011534	0,13250	843,4	2790,8	1947,4	2,3119	6,4453	4,1334
199	1,5224·10 ⁶	0,0011550	0,12983	847,9	2791,5	1943,6	2,3213	6,4378	4,1164
200	1,5547·10 ⁶	0,0011565	0,12722	852,4	2792,1	1939,7	2,3308	6,4303	4,0995
201	1,5875·10 ⁶	0,0011581	0,12468	856,9	2792,7	1935,8	2,3402	6,4228	4,0826
202	1,6208·10 ⁶	0,0011597	0,12220	861,4	2793,2	1931,8	2,3497	6,4154	4,0657
203	1,6546·10 ⁶	0,0011612	0,11977	865,9	2793,8	1927,9	2,3591	6,4080	4,0489
204	1,6891·10 ⁶	0,0011629	0,11740	870,5	2794,4	1923,9	2,3685	6,4006	4,0321
205	1,7240·10 ⁶	0,0011645	0,11509	875,0	2794,9	1919,9	2,3779	6,3932	4,0153
206	1,7596·10 ⁶	0,0011661	0,11283	879,5	2795,4	1915,9	2,3873	6,3858	3,9985
207	1,7956·10 ⁶	0,0011677	0,11062	884,1	2795,9	1911,9	2,3967	6,3785	3,9818
208	1,8323·10 ⁶	0,0011694	0,10847	888,6	2796,4	1907,8	2,4060	6,3711	3,9651
209	1,8696·10 ⁶	0,0011710	0,10636	893,2	2796,9	1903,7	2,4154	6,3638	3,9484
210	1,9074·10 ⁶	0,0011727	0,10430	897,7	2797,4	1899,6	2,4248	6,3565	3,9318
211	1,9458·10 ⁶	0,0011744	0,10229	902,3	2797,8	1895,5	2,4341	6,3492	3,9151
212	1,9848·10 ⁶	0,0011761	0,10032	906,9	2798,2	1891,4	2,4434	6,3420	3,8985
213	2,0245·10 ⁶	0,0011778	0,09840	911,4	2798,6	1887,2	2,4528	6,3347	3,8819
214	2,0647·10 ⁶	0,0011795	0,09652	916,0	2799,0	1883,0	2,4621	6,3275	3,8654
215	2,1055·10 ⁶	0,0011813	0,09469	920,6	2799,4	1878,8	2,4714	6,3202	3,8488
216	2,1470·10 ⁶	0,0011830	0,09289	925,2	2799,8	1874,6	2,4807	6,3130	3,8323
217	2,1891·10 ⁶	0,0011848	0,09114	929,8	2800,1	1870,3	2,4900	6,3058	3,8158
218	2,2319·10 ⁶	0,0011866	0,08942	934,4	2800,4	1866,0	2,4993	6,2986	3,7993
219	2,2753·10 ⁶	0,0011884	0,08774	939,0	2800,8	1861,7	2,5085	6,2914	3,7829

t	p	v	v ⁻	i	i ⁻	r	s	s ⁻	s ⁻ -s
220	2,3193·10 ⁶	0,0011902	0,08610	943,6	2801,1	1857,4	2,5178	6,2842	3,7664
221	2,3640·10 ⁶	0,0011920	0,08449	948,3	2801,3	1853,1	2,5271	6,2771	3,7500
222	2,4093·10 ⁶	0,0011938	0,08292	952,9	2801,6	1848,7	2,5363	6,2699	3,7336
223	2,4553·10 ⁶	0,0011957	0,08139	957,5	2801,8	1844,3	2,5456	6,2628	3,7172
224	2,5020·10 ⁶	0,0011975	0,07988	962,2	2802,1	1839,9	2,5548	6,2557	3,7008
225	2,5494·10 ⁶	0,0011994	0,07841	966,8	2802,3	1835,4	2,5641	6,2485	3,6845
226	2,5975·10 ⁶	0,0012013	0,07697	971,5	2802,4	1830,9	2,5733	6,2414	3,6681
227	2,6463·10 ⁶	0,0012032	0,07556	976,2	2802,6	1826,4	2,5825	6,2343	3,6518
228	2,6957·10 ⁶	0,0012051	0,07418	980,8	2802,8	1821,9	2,5917	6,2272	3,6355
229	2,7459·10 ⁶	0,0012071	0,07283	985,5	2802,9	1817,4	2,6009	6,2201	3,6192
230	2,7968·10 ⁶	0,0012090	0,07151	990,2	2803,0	1812,8	2,6102	6,2131	3,6029
231	2,8484·10 ⁶	0,0012110	0,07022	994,9	2803,1	1808,2	2,6194	6,2060	3,5866
232	2,9008·10 ⁶	0,0012130	0,06895	999,6	2803,2	1803,6	2,6285	6,1989	3,5704
233	2,9538·10 ⁶	0,0012150	0,06771	1004,3	2803,2	1798,9	2,6377	6,1918	3,5541
234	3,0077·10 ⁶	0,0012170	0,06649	1009,0	2803,3	1794,2	2,6469	6,1848	3,5379
235	3,0622·10 ⁶	0,0012190	0,06530	1013,8	2803,3	1789,5	2,6561	6,1777	3,5216
236	3,1176·10 ⁶	0,0012211	0,06414	1018,5	2803,3	1784,8	2,6653	6,1707	3,5054
237	3,1737·10 ⁶	0,0012231	0,06300	1023,2	2803,3	1780,0	2,6744	6,1636	3,4892
238	3,2306·10 ⁶	0,0012252	0,06188	1028,0	2803,2	1775,2	2,6836	6,1566	3,4730
239	3,2882·10 ⁶	0,0012273	0,06078	1032,8	2803,1	1770,4	2,6928	6,1496	3,4568
240	3,3467·10 ⁶	0,0012295	0,05971	1037,5	2803,1	1765,5	2,7019	6,1425	3,4406
241	3,4059·10 ⁶	0,0012316	0,05866	1042,3	2803,0	1760,7	2,7111	6,1355	3,4244
242	3,4659·10 ⁶	0,0012338	0,05763	1047,1	2802,8	1755,7	2,7203	6,1285	3,4082
243	3,5268·10 ⁶	0,0012359	0,05662	1051,9	2802,7	1750,8	2,7294	6,1214	3,3920
244	3,5884·10 ⁶	0,0012381	0,05563	1056,7	2802,5	1745,8	2,7385	6,1144	3,3759
245	3,6509·10 ⁶	0,0012404	0,05466	1061,5	2802,3	1740,8	2,7477	6,1074	3,3597
246	3,7142·10 ⁶	0,0012426	0,05371	1066,3	2802,1	1735,8	2,7568	6,1003	3,3435
247	3,7784·10 ⁶	0,0012448	0,05278	1071,1	2801,9	1730,7	2,7660	6,0933	3,3273
248	3,8434·10 ⁶	0,0012471	0,05186	1076,0	2801,6	1725,6	2,7751	6,0863	3,3112
249	3,9092·10 ⁶	0,0012494	0,05097	1080,8	2801,3	1720,5	2,7843	6,0793	3,2950
250	3,9759·10 ⁶	0,0012517	0,05009	1085,7	2801,0	1715,3	2,7934	6,0722	3,2788
251	4,0435·10 ⁶	0,0012541	0,04922	1090,6	2800,7	1710,1	2,8025	6,0652	3,2627
252	4,1120·10 ⁶	0,0012564	0,04838	1095,4	2800,3	1704,9	2,8117	6,0582	3,2465
253	4,1813·10 ⁶	0,0012588	0,04755	1100,3	2800,0	1699,6	2,8208	6,0511	3,2303
254	4,2515·10 ⁶	0,0012612	0,04674	1105,2	2799,6	1694,3	2,8299	6,0441	3,2141
255	4,3227·10 ⁶	0,0012636	0,04594	1110,1	2799,1	1689,0	2,8391	6,0370	3,1980
256	4,3947·10 ⁶	0,0012661	0,04516	1115,0	2798,7	1683,6	2,8482	6,0300	3,1818
257	4,4677·10 ⁶	0,0012686	0,04439	1120,0	2798,2	1678,2	2,8573	6,0229	3,1656
258	4,5415·10 ⁶	0,0012711	0,04364	1124,9	2797,7	1672,8	2,8664	6,0158	3,1494
259	4,6163·10 ⁶	0,0012736	0,04290	1129,9	2797,2	1667,3	2,8756	6,0088	3,1332
260	4,6921·10 ⁶	0,0012761	0,04218	1134,8	2796,6	1661,8	2,8847	6,0017	3,1170
261	4,7688·10 ⁶	0,0012787	0,04146	1139,8	2796,1	1656,3	2,8939	5,9946	3,1008
262	4,8464·10 ⁶	0,0012813	0,04077	1144,8	2795,5	1650,7	2,9030	5,9875	3,0845

t	p	v	v'	i	i'	r	s	s'	s'-s
263	4,9250·10 ⁶	0,0012839	0,04008	1149,8	2794,8	1645,1	2,9121	5,9804	3,0683
264	5,0046·10 ⁶	0,0012866	0,03941	1154,8	2794,2	1639,4	2,9213	5,9733	3,0520
265	5,0851·10 ⁶	0,0012892	0,03875	1159,8	2793,5	1633,7	2,9304	5,9662	3,0358
266	5,1667·10 ⁶	0,0012919	0,03810	1164,8	2792,8	1628,0	2,9396	5,9590	3,0195
267	5,2492·10 ⁶	0,0012947	0,03746	1169,9	2792,1	1622,2	2,9487	5,9519	3,0032
268	5,3327·10 ⁶	0,0012974	0,03684	1174,9	2791,3	1616,4	2,9579	5,9448	2,9869
269	5,4173·10 ⁶	0,0013002	0,03622	1180,0	2790,5	1610,5	2,9670	5,9376	2,9706
270	5,5028·10 ⁶	0,0013030	0,03562	1185,1	2789,7	1604,6	2,9762	5,9304	2,9542
271	5,5894·10 ⁶	0,0013058	0,03503	1190,2	2788,8	1598,7	2,9853	5,9232	2,9379
272	5,6771·10 ⁶	0,0013087	0,03445	1195,3	2788,0	1592,7	2,9945	5,9160	2,9215
273	5,7657·10 ⁶	0,0013116	0,03388	1200,4	2787,1	1586,6	3,0037	5,9088	2,9051
274	5,8555·10 ⁶	0,0013146	0,03332	1205,6	2786,1	1580,6	3,0129	5,9016	2,8887
275	5,9463·10 ⁶	0,0013175	0,03277	1210,7	2785,1	1574,4	3,0221	5,8943	2,8723
276	6,0381·10 ⁶	0,0013205	0,03223	1215,9	2784,1	1568,3	3,0312	5,8871	2,8558
277	6,1311·10 ⁶	0,0013235	0,03169	1221,0	2783,1	1562,1	3,0404	5,8798	2,8393
278	6,2251·10 ⁶	0,0013266	0,03117	1226,2	2782,0	1555,8	3,0496	5,8725	2,8228
279	6,3202·10 ⁶	0,0013297	0,03066	1231,4	2781,0	1549,5	3,0589	5,8652	2,8063
280	6,4165·10 ⁶	0,0013328	0,03015	1236,7	2779,8	1543,2	3,0681	5,8578	2,7898
281	6,5138·10 ⁶	0,0013360	0,02966	1241,9	2778,7	1536,8	3,0773	5,8505	2,7732
282	6,6123·10 ⁶	0,0013392	0,02917	1247,2	2777,5	1530,3	3,0865	5,8431	2,7566
283	6,7119·10 ⁶	0,0013425	0,02869	1252,4	2776,2	1523,8	3,0958	5,8357	2,7399
284	6,8126·10 ⁶	0,0013457	0,02822	1257,7	2775,0	1517,3	3,1050	5,8283	2,7232
285	6,9145·10 ⁶	0,0013491	0,02776	1263,0	2773,7	1510,7	3,1143	5,8208	2,7065
286	7,0176·10 ⁶	0,0013524	0,02730	1268,3	2772,3	1504,0	3,1236	5,8134	2,6898
287	7,1218·10 ⁶	0,0013558	0,02686	1273,7	2771,0	1497,3	3,1329	5,8059	2,6730
288	7,2272·10 ⁶	0,0013593	0,02642	1279,0	2769,6	1490,5	3,1421	5,7984	2,6562
289	7,3338·10 ⁶	0,0013628	0,02598	1284,4	2768,1	1483,7	3,1515	5,7908	2,6393
290	7,4416·10 ⁶	0,0013663	0,02556	1289,8	2766,6	1476,8	3,1608	5,7832	2,6225
291	7,5506·10 ⁶	0,0013699	0,02514	1295,2	2765,1	1469,9	3,1701	5,7756	2,6055
292	7,6609·10 ⁶	0,0013735	0,02473	1300,6	2763,6	1462,9	3,1794	5,7680	2,5886
293	7,7723·10 ⁶	0,0013772	0,02432	1306,1	2761,9	1455,9	3,1888	5,7603	2,5715
294	7,8850·10 ⁶	0,0013809	0,02392	1311,5	2760,3	1448,8	3,1982	5,7526	2,5545
295	7,9990·10 ⁶	0,0013846	0,02353	1317,0	2758,6	1441,6	3,2076	5,7449	2,5374
296	8,1142·10 ⁶	0,0013884	0,02315	1322,5	2756,9	1434,4	3,2170	5,7372	2,5202
297	8,2306·10 ⁶	0,0013923	0,02277	1328,1	2755,1	1427,1	3,2264	5,7294	2,5030
298	8,3484·10 ⁶	0,0013962	0,02239	1333,6	2753,3	1419,7	3,2358	5,7215	2,4857
299	8,4674·10 ⁶	0,0014002	0,02202	1339,2	2751,5	1412,3	3,2453	5,7137	2,4684
300	8,5877·10 ⁶	0,0014042	0,02166	1344,8	2749,6	1404,8	3,2547	5,7058	2,4510
301	8,7093·10 ⁶	0,0014083	0,02131	1350,4	2747,6	1397,2	3,2642	5,6978	2,4336
302	8,8323·10 ⁶	0,0014124	0,02096	1356,0	2745,6	1389,6	3,2737	5,6898	2,4161
303	8,9566·10 ⁶	0,0014167	0,02061	1361,7	2743,6	1381,9	3,2833	5,6818	2,3985
304	9,0822·10 ⁶	0,0014209	0,02027	1367,4	2741,5	1374,1	3,2928	5,6737	2,3809
305	9,2092·10 ⁶	0,0014252	0,01994	1373,1	2739,4	1366,3	3,3024	5,6656	2,3632

t	p	v	v''	i	i''	r	s	s''	$s'' - s$
306	9,3375·10 ⁶	0,0014296	0,01961	1378,8	2737,2	1358,4	3,3120	5,6575	2,3455
307	9,4672·10 ⁶	0,0014341	0,01928	1384,6	2735,0	1350,4	3,3216	5,6492	2,3277
308	9,5983·10 ⁶	0,0014386	0,01896	1390,4	2732,7	1342,3	3,3312	5,6410	2,3098
309	9,7308·10 ⁶	0,0014432	0,01865	1396,2	2730,3	1334,2	3,3409	5,6327	2,2918
310	9,8647·10 ⁶	0,0014479	0,01834	1402,0	2727,9	1325,9	3,3506	5,6243	2,2737
311	1,0000·10 ⁷	0,0014526	0,01803	1407,9	2725,5	1317,6	3,3603	5,6159	2,2556
312	1,0137·10 ⁷	0,0014574	0,01773	1413,8	2723,0	1309,2	3,3700	5,6074	2,2374
313	1,0275·10 ⁷	0,0014623	0,01744	1419,7	2720,4	1300,7	3,3798	5,5989	2,2191
314	1,0415·10 ⁷	0,0014673	0,01714	1425,6	2717,8	1292,1	3,3896	5,5903	2,2007
315	1,0556·10 ⁷	0,0014724	0,01686	1431,6	2715,1	1283,4	3,3994	5,5816	2,1822
316	1,0698·10 ⁷	0,0014775	0,01657	1437,6	2712,3	1274,7	3,4093	5,5729	2,1636
317	1,0842·10 ⁷	0,0014828	0,01629	1443,7	2709,5	1265,8	3,4192	5,5641	2,1449
318	1,0988·10 ⁷	0,0014881	0,01602	1449,8	2706,6	1256,8	3,4291	5,5553	2,1261
319	1,1135·10 ⁷	0,0014935	0,01574	1455,9	2703,7	1247,8	3,4391	5,5463	2,1072
320	1,1284·10 ⁷	0,0014991	0,01548	1462,1	2700,7	1238,6	3,4491	5,5373	2,0882
321	1,1434·10 ⁷	0,0015047	0,01521	1468,2	2697,6	1229,3	3,4592	5,5282	2,0691
322	1,1586·10 ⁷	0,0015104	0,01495	1474,5	2694,4	1220,0	3,4692	5,5191	2,0498
323	1,1739·10 ⁷	0,0015163	0,01469	1480,7	2691,2	1210,5	3,4794	5,5098	2,0305
324	1,1894·10 ⁷	0,0015222	0,01444	1487,0	2687,9	1200,8	3,4895	5,5005	2,0110
325	1,2051·10 ⁷	0,0015283	0,01419	1493,4	2684,5	1191,1	3,4997	5,4911	1,9913
326	1,2209·10 ⁷	0,0015345	0,01394	1499,8	2681,0	1181,3	3,5100	5,4816	1,9715
327	1,2368·10 ⁷	0,0015408	0,01370	1506,2	2677,5	1171,3	3,5203	5,4719	1,9516
328	1,2530·10 ⁷	0,0015473	0,01346	1512,7	2673,8	1161,2	3,5307	5,4622	1,9316
329	1,2693·10 ⁷	0,0015539	0,01322	1519,2	2670,1	1150,9	3,5411	5,4524	1,9113
330	1,2858·10 ⁷	0,0015606	0,01298	1525,7	2666,2	1140,5	3,5516	5,4425	1,8909
331	1,3024·10 ⁷	0,0015675	0,01275	1532,4	2662,3	1130,0	3,5621	5,4324	1,8703
332	1,3192·10 ⁷	0,0015745	0,01252	1539,0	2658,3	1119,3	3,5727	5,4223	1,8496
333	1,3362·10 ⁷	0,0015817	0,01230	1545,7	2654,2	1108,4	3,5833	5,4120	1,8287
334	1,3533·10 ⁷	0,0015891	0,01207	1552,5	2649,9	1097,4	3,5940	5,4016	1,8075
335	1,3707·10 ⁷	0,0015967	0,01185	1559,3	2645,6	1086,3	3,6048	5,3910	1,7862
336	1,3882·10 ⁷	0,0016044	0,01163	1566,2	2641,1	1074,9	3,6157	5,3803	1,7646
337	1,4059·10 ⁷	0,0016124	0,01142	1573,2	2636,6	1063,4	3,6266	5,3694	1,7428
338	1,4237·10 ⁷	0,0016205	0,01120	1580,2	2631,9	1051,7	3,6376	5,3584	1,7208
339	1,4418·10 ⁷	0,0016289	0,01099	1587,3	2627,0	1039,7	3,6488	5,3473	1,6985
340	1,4600·10 ⁷	0,0016375	0,01078	1594,4	2622,1	1027,6	3,6599	5,3359	1,6760
341	1,4784·10 ⁷	0,0016464	0,01058	1601,7	2617,0	1015,3	3,6712	5,3244	1,6531
342	1,4970·10 ⁷	0,0016555	0,01037	1609,0	2611,7	1002,7	3,6826	5,3127	1,6300
343	1,5158·10 ⁷	0,0016649	0,01017	1616,4	2606,3	989,9	3,6941	5,3008	1,6066
344	1,5348·10 ⁷	0,0016746	0,009969	1623,9	2600,7	976,9	3,7058	5,2886	1,5829
345	1,5540·10 ⁷	0,0016846	0,009770	1631,4	2595,0	963,6	3,7175	5,2763	1,5588
346	1,5734·10 ⁷	0,0016949	0,009573	1639,1	2589,1	950,0	3,7294	5,2637	1,5344
347	1,5930·10 ⁷	0,0017056	0,009377	1646,9	2583,0	936,1	3,7414	5,2509	1,5095
348	1,6127·10 ⁷	0,0017167	0,009184	1654,8	2576,7	922,0	3,7535	5,2378	1,4843

t	p	v	v [~]	i	i [~]	r	s	s [~]	s [~] - s
349	1,6327·10 ⁷	0,0017282	0,008992	1662,7	2570,3	907,5	3,7658	5,2245	1,4587
350	1,6529·10 ⁷	0,0017401	0,008801	1670,9	2563,6	892,7	3,7783	5,2109	1,4326
351	1,6733·10 ⁷	0,0017525	0,008612	1679,1	2556,7	877,6	3,7910	5,1970	1,4060
352	1,6939·10 ⁷	0,0017654	0,008425	1687,5	2549,6	862,0	3,8039	5,1828	1,3789
353	1,7147·10 ⁷	0,0017789	0,008237	1696,1	2542,1	846,0	3,8169	5,1681	1,3512
354	1,7358·10 ⁷	0,0017930	0,008051	1704,8	2534,4	829,6	3,8302	5,1531	1,3229
355	1,7570·10 ⁷	0,0018078	0,007866	1713,7	2526,4	812,7	3,8438	5,1377	1,2939
356	1,7785·10 ⁷	0,0018233	0,007681	1722,8	2518,1	795,3	3,8576	5,1218	1,2642
357	1,8002·10 ⁷	0,0018396	0,007497	1732,1	2509,5	777,4	3,8718	5,1054	1,2336
358	1,8221·10 ⁷	0,0018569	0,007313	1741,6	2500,4	758,8	3,8863	5,0885	1,2022
359	1,8443·10 ⁷	0,0018751	0,007130	1751,4	2491,0	739,5	3,9011	5,0710	1,1699
360	1,8666·10 ⁷	0,0018945	0,006946	1761,5	2481,0	719,5	3,9164	5,0528	1,1364
361	1,8893·10 ⁷	0,0019152	0,006761	1771,9	2470,6	698,7	3,9321	5,0339	1,1018
362	1,9121·10 ⁷	0,0019374	0,006575	1782,6	2459,6	677,0	3,9483	5,0141	1,0658
363	1,9352·10 ⁷	0,0019613	0,006387	1793,8	2447,8	654,0	3,9652	4,9934	1,0282
364	1,9586·10 ⁷	0,0019873	0,006197	1805,4	2435,4	630,0	3,9827	4,9715	0,9888
365	1,9822·10 ⁷	0,0020156	0,006006	1817,6	2422,1	604,5	4,0011	4,9484	0,9473
366	2,0061·10 ⁷	0,0020469	0,005809	1830,5	2407,8	577,3	4,0204	4,9237	0,9033
367	2,0302·10 ⁷	0,0020819	0,005608	1844,1	2392,1	548,0	4,0410	4,8971	0,8561
368	2,0546·10 ⁷	0,0021215	0,005399	1858,8	2374,9	516,1	4,0631	4,8681	0,8050
369	2,0793·10 ⁷	0,0021674	0,005179	1874,8	2355,5	480,7	4,0873	4,8360	0,7487
370	2,1043·10 ⁷	0,0022220	0,004947	1892,7	2333,6	440,9	4,1142	4,7998	0,6856
371	2,1296·10 ⁷	0,0022902	0,004692	1913,3	2307,5	394,3	4,1453	4,7573	0,6120
372	2,1553·10 ⁷	0,0023817	0,004398	1938,5	2274,6	336,1	4,1836	4,7046	0,5210
373	2,1813·10 ⁷	0,0025264	0,004019	1974,1	2227,3	253,2	4,2375	4,6295	0,3920
373,946	2,2064·10 ⁷	0,003106	0,003106	2087,5	2087,5	0,0	4,4120	4,4120	0,0

Kritik vaziyat ko'rsatkichi:

Bosim, MPa.....	22,064
Harorat, °C.....	373,946
Solishtirma hajm, m ³ /kg.....	0,003106
Solishtirma entalpiya, kJ/kg.....	2087,5
Solishtirma entropiya, kJ/(kg · °K).....	4,4120

**Suv va suv bug'ı termodinamik ko'rsatkichini bosim
bo'yicha vaziyatda singdirish**

p	t	v	v'	i	i'	r	s	s'	s' - s
1,00·10 ³	6,97	0,0010001	129,183	29,30	2513,7	2484,4	0,1059	8,9749	8,8690
1,50·10 ³	13,02	0,0010007	87,962	54,69	2524,7	2470,1	0,1956	8,8270	8,6315
2,00·10 ³	17,50	0,0010014	66,990	73,43	2532,9	2459,5	0,2606	8,7227	8,4621
2,20·10 ³	19,01	0,0010016	61,213	79,79	2535,7	2455,9	0,2824	8,6883	8,4059
2,40·10 ³	20,41	0,0010019	56,377	85,66	2538,2	2452,6	0,3024	8,6569	8,3545
2,50·10 ³	21,08	0,0010021	54,242	88,43	2539,4	2451,0	0,3119	8,6422	8,3303
2,60·10 ³	21,72	0,0010022	52,267	91,11	2540,6	2449,5	0,3210	8,6280	8,3071
2,80·10 ³	22,94	0,0010025	48,731	96,20	2542,8	2446,6	0,3382	8,6014	8,2632
3,00·10 ³	24,08	0,0010028	45,655	100,99	2544,9	2443,9	0,3543	8,5766	8,2222
3,20·10 ³	25,16	0,0010030	42,954	105,51	2546,8	2441,3	0,3695	8,5534	8,1839
3,40·10 ³	26,18	0,0010033	40,563	109,78	2548,7	2438,9	0,3838	8,5316	8,1479
3,50·10 ³	26,67	0,0010034	39,468	111,84	2549,6	2437,7	0,3907	8,5213	8,1306
3,60·10 ³	27,15	0,0010036	38,432	113,84	2550,4	2436,6	0,3973	8,5112	8,1138
3,80·10 ³	28,08	0,0010038	36,519	117,71	2552,1	2434,4	0,4102	8,4918	8,0816
4,00·10 ³	28,96	0,0010041	34,792	121,40	2553,7	2432,3	0,4224	8,4735	8,0510
4,20·10 ³	29,81	0,0010044	33,226	124,94	2555,2	2430,3	0,4341	8,4561	8,0219
4,40·10 ³	30,62	0,0010046	31,799	128,33	2556,7	2428,4	0,4453	8,4395	7,9941
4,50·10 ³	31,01	0,0010047	31,132	129,98	2557,4	2427,4	0,4507	8,4314	7,9807
4,60·10 ³	31,40	0,0010048	30,493	131,60	2558,1	2426,5	0,4560	8,4236	7,9676
4,80·10 ³	32,15	0,0010051	29,293	134,74	2559,5	2424,7	0,4663	8,4084	7,9421
5,00·10 ³	32,88	0,0010053	28,186	137,77	2560,8	2423,0	0,4763	8,3939	7,9177
5,20·10 ³	33,58	0,0010056	27,163	140,69	2562,0	2421,3	0,4858	8,3800	7,8942
5,40·10 ³	34,25	0,0010058	26,213	143,52	2563,2	2419,7	0,4950	8,3665	7,8715
5,50·10 ³	34,58	0,0010059	25,763	144,90	2563,8	2418,9	0,4995	8,3600	7,8605
5,60·10 ³	34,91	0,0010060	25,329	146,26	2564,4	2418,2	0,5039	8,3536	7,8497
5,80·10 ³	35,54	0,0010062	24,505	148,92	2565,6	2416,6	0,5125	8,3412	7,8286
6,00·10 ³	36,16	0,0010064	23,734	151,49	2566,7	2415,2	0,5209	8,3291	7,8083
6,20·10 ³	36,76	0,0010067	23,012	154,00	2567,7	2413,7	0,5290	8,3175	7,7886
6,40·10 ³	37,34	0,0010069	22,334	156,43	2568,8	2412,4	0,5368	8,3063	7,7695
6,50·10 ³	37,63	0,0010070	22,010	157,63	2569,3	2411,7	0,5407	8,3008	7,7601
6,60·10 ³	37,91	0,0010071	21,695	158,80	2569,8	2411,0	0,5444	8,2954	7,7509
6,80·10 ³	38,46	0,0010073	21,093	161,11	2570,8	2409,7	0,5519	8,2848	7,7330
7,00·10 ³	39,00	0,0010075	20,525	163,37	2571,8	2408,4	0,5591	8,2746	7,7155
7,20·10 ³	39,53	0,0010077	19,988	165,56	2572,7	2407,1	0,5661	8,2646	7,6985
7,40·10 ³	40,04	0,0010079	19,478	167,71	2573,6	2405,9	0,5730	8,2549	7,6820
7,50·10 ³	40,29	0,0010080	19,234	168,76	2574,1	2405,3	0,5763	8,2502	7,6739
8,00·10 ³	41,51	0,0010085	18,099	173,85	2576,2	2402,4	0,5925	8,2274	7,6349
8,50·10 ³	42,66	0,0010089	17,095	178,68	2578,3	2399,6	0,6078	8,2060	7,5982
9,00·10 ³	43,76	0,0010094	16,200	183,26	2580,3	2397,0	0,6223	8,1859	7,5636
9,50·10 ³	44,81	0,0010098	15,396	187,63	2582,1	2394,5	0,6361	8,1669	7,5308

2-jadval (davomi)

p	t	v'	v''	i'	i''	r	s'	s''	s''-s'
1,00·10 ⁴	45,81	0,0010103	14,671	191,81	2583,9	2392,1	0,6492	8,1489	7,4997
1,10·10 ⁴	47,68	0,0010111	13,412	199,66	2587,2	2387,6	0,6737	8,1155	7,4417
1,20·10 ⁴	49,42	0,0010119	12,359	206,91	2590,3	2383,4	0,6963	8,0850	7,3887
1,30·10 ⁴	51,04	0,0010126	11,463	213,66	2593,1	2379,5	0,7172	8,0570	7,3399
1,40·10 ⁴	52,55	0,0010133	10,691	219,99	2595,8	2375,8	0,7366	8,0312	7,2945
1,50·10 ⁴	53,97	0,0010140	10,025	225,94	2598,3	2372,4	0,7548	8,0071	7,2523
1,60·10 ⁴	55,31	0,0010147	9,4309	231,55	2600,7	2369,1	0,7720	7,9847	7,2127
1,70·10 ⁴	56,59	0,0010153	8,9089	236,88	2602,9	2366,0	0,7882	7,9636	7,1754
1,80·10 ⁴	57,80	0,0010160	8,4433	241,95	2605,0	2363,1	0,8035	7,9437	7,1403
1,90·10 ⁴	58,95	0,0010166	8,0254	246,78	2607,0	2360,2	0,8181	7,9250	7,1069
2,00·10 ⁴	60,06	0,0010171	7,6482	251,40	2608,9	2357,5	0,8320	7,9072	7,0753
2,10·10 ⁴	61,12	0,0010177	7,3058	255,83	2610,8	2355,0	0,8452	7,8904	7,0451
2,20·10 ⁴	62,13	0,0010183	6,9938	260,08	2612,6	2352,5	0,8579	7,8743	7,0164
2,30·10 ⁴	63,11	0,0010188	6,7081	264,17	2614,2	2350,1	0,8701	7,8589	6,9888
2,40·10 ⁴	64,05	0,0010193	6,4455	268,12	2615,9	2347,8	0,8818	7,8442	6,9624
2,50·10 ⁴	64,96	0,0010198	6,2034	271,93	2617,4	2345,5	0,8931	7,8302	6,9371
2,60·10 ⁴	65,84	0,0010203	5,9793	275,61	2619,0	2343,4	0,9040	7,8167	6,9127
2,70·10 ⁴	66,69	0,0010208	5,7714	279,17	2620,4	2341,3	0,9145	7,8037	6,8892
2,80·10 ⁴	67,52	0,0010213	5,5779	282,62	2621,8	2339,2	0,9246	7,7912	6,8666
2,90·10 ⁴	68,32	0,0010218	5,3974	285,97	2623,2	2337,2	0,9344	7,7791	6,8447
3,00·10 ⁴	69,10	0,0010222	5,2286	289,23	2624,6	2335,3	0,9439	7,7675	6,8235
3,20·10 ⁴	70,59	0,0010231	4,9216	295,47	2627,1	2331,6	0,9621	7,7453	6,7832
3,40·10 ⁴	72,00	0,0010240	4,6498	301,40	2629,5	2328,1	0,9793	7,7245	6,7452
3,60·10 ⁴	73,35	0,0010248	4,4073	307,04	2631,8	2324,8	0,9956	7,7050	6,7093
3,80·10 ⁴	74,63	0,0010256	4,1897	312,42	2634,0	2321,6	1,0111	7,6865	6,6754
4,00·10 ⁴	75,86	0,0010264	3,9931	317,57	2636,1	2318,5	1,0259	7,6690	6,6431
4,20·10 ⁴	77,03	0,0010271	3,8147	322,50	2638,0	2315,5	1,0400	7,6523	6,6123
4,40·10 ⁴	78,17	0,0010278	3,6521	327,25	2639,9	2312,7	1,0535	7,6365	6,5829
4,60·10 ⁴	79,25	0,0010286	3,5032	331,82	2641,8	2309,9	1,0665	7,6213	6,5548
4,80·10 ⁴	80,30	0,0010292	3,3664	336,22	2643,5	2307,3	1,0790	7,6068	6,5279
5,00·10 ⁴	81,32	0,0010299	3,2401	340,48	2645,2	2304,7	1,0910	7,5930	6,5020
5,50·10 ⁴	83,71	0,0010315	2,9636	350,52	2649,2	2298,7	1,1192	7,5606	6,4414
6,00·10 ⁴	85,93	0,0010331	2,7318	359,84	2652,9	2293,0	1,1452	7,5311	6,3859
6,50·10 ⁴	87,99	0,0010345	2,5347	368,53	2656,2	2287,7	1,1694	7,5040	6,3346
7,00·10 ⁴	89,93	0,0010359	2,3649	376,68	2659,4	2282,7	1,1919	7,4790	6,2871
7,50·10 ⁴	91,76	0,0010372	2,2171	384,37	2662,4	2278,0	1,2130	7,4557	6,2427
8,00·10 ⁴	93,49	0,0010385	2,0872	391,64	2665,2	2273,5	1,2328	7,4339	6,2011
8,50·10 ⁴	95,13	0,0010397	1,9721	398,55	2667,8	2269,3	1,2516	7,4135	6,1618
9,00·10 ⁴	96,69	0,0010409	1,8695	405,13	2670,3	2265,2	1,2694	7,3942	6,1248
9,50·10 ⁴	98,18	0,0010420	1,7773	411,42	2672,7	2261,3	1,2864	7,3760	6,0897
1,00·10 ⁵	99,61	0,0010431	1,6940	417,44	2674,9	2257,5	1,3026	7,3588	6,0562
1,10·10 ⁵	102,29	0,0010453	1,5496	428,77	2679,2	2250,4	1,3328	7,3268	5,9940

p	t	v	v ⁻	i	i ⁻	r	s	s ⁻	s ⁻ -s'
1,20-10 ⁵	104,78	0,0010473	1,4284	439,30	2683,1	2243,8	1,3608	7,2976	5,9369
1,30-10 ⁵	107,11	0,0010492	1,3254	449,13	2686,6	2237,5	1,3867	7,2708	5,8842
1,40-10 ⁵	109,29	0,0010510	1,2366	458,37	2690,0	2231,6	1,4109	7,2460	5,8352
1,50-10 ⁵	111,35	0,0010527	1,1594	467,08	2693,1	2226,0	1,4335	7,2229	5,7894
1,60-10 ⁵	113,30	0,0010544	1,0914	475,34	2696,0	2220,7	1,4549	7,2014	5,7464
1,70-10 ⁵	115,15	0,0010560	1,0312	483,18	2698,8	2215,6	1,4752	7,1811	5,7059
1,80-10 ⁵	116,91	0,0010576	0,97753	490,67	2701,4	2210,7	1,4944	7,1620	5,6677
1,90-10 ⁵	118,60	0,0010591	0,92930	497,82	2703,9	2206,1	1,5127	7,1440	5,6313
2,00-10 ⁵	120,21	0,0010605	0,88574	504,7	2706,2	2201,6	1,5301	7,1269	5,5968
2,10-10 ⁵	121,76	0,0010619	0,84619	511,3	2708,5	2197,2	1,5468	7,1106	5,5638
2,20-10 ⁵	123,25	0,0010633	0,81012	517,6	2710,6	2193,0	1,5628	7,0951	5,5323
2,30-10 ⁵	124,69	0,0010646	0,77709	523,7	2712,7	2188,9	1,5782	7,0802	5,5021
2,40-10 ⁵	126,07	0,0010659	0,74672	529,6	2714,6	2185,0	1,5930	7,0660	5,4731
2,50-10 ⁵	127,41	0,0010672	0,71870	535,4	2716,5	2181,2	1,6072	7,0524	5,4452
2,60-10 ⁵	128,71	0,0010685	0,69276	540,9	2718,3	2177,4	1,6210	7,0393	5,4183
2,70-10 ⁵	129,97	0,0010697	0,66869	546,3	2720,0	2173,8	1,6343	7,0267	5,3924
2,80-10 ⁵	131,19	0,0010709	0,64627	551,5	2721,7	2170,3	1,6472	7,0146	5,3674
2,90-10 ⁵	132,37	0,0010720	0,62536	556,5	2723,3	2166,8	1,6597	7,0029	5,3432
3,00-10 ⁵	133,53	0,0010732	0,60579	561,5	2724,9	2163,4	1,6718	6,9916	5,3198
3,10-10 ⁵	134,65	0,0010743	0,58744	566,3	2726,4	2160,1	1,6835	6,9806	5,2971
3,20-10 ⁵	135,74	0,0010754	0,57020	570,9	2727,9	2156,9	1,6950	6,9700	5,2751
3,30-10 ⁵	136,81	0,0010765	0,55397	575,5	2729,3	2153,8	1,7061	6,9597	5,2537
3,40-10 ⁵	137,85	0,0010775	0,53866	580,0	2730,6	2150,7	1,7169	6,9498	5,2329
3,50-10 ⁵	138,86	0,0010786	0,52420	584,3	2732,0	2147,7	1,7275	6,9401	5,2126
3,60-10 ⁵	139,85	0,0010796	0,51051	588,6	2733,3	2144,7	1,7378	6,9307	5,1929
3,70-10 ⁵	140,82	0,0010806	0,49754	592,7	2734,5	2141,8	1,7478	6,9215	5,1737
3,80-10 ⁵	141,77	0,0010816	0,48523	596,8	2735,7	2138,9	1,7576	6,9126	5,1550
3,90-10 ⁵	142,70	0,0010826	0,47353	600,8	2736,9	2136,1	1,7672	6,9039	5,1367
4,00-10 ⁵	143,61	0,0010836	0,46239	604,7	2738,1	2133,3	1,7766	6,8954	5,1188
4,10-10 ⁵	144,50	0,0010845	0,45178	608,6	2739,2	2130,6	1,7858	6,8872	5,1014
4,20-10 ⁵	145,38	0,0010855	0,44166	612,3	2740,3	2127,9	1,7948	6,8791	5,0843
4,30-10 ⁵	146,24	0,0010864	0,43199	616,0	2741,3	2125,3	1,8036	6,8712	5,0676
4,40-10 ⁵	147,08	0,0010873	0,42275	619,7	2742,4	2122,7	1,8122	6,8635	5,0513
4,50-10 ⁵	147,91	0,0010882	0,41390	623,2	2743,4	2120,2	1,8206	6,8560	5,0353
4,60-10 ⁵	148,72	0,0010891	0,40543	626,7	2744,4	2117,6	1,8289	6,8486	5,0197
4,70-10 ⁵	149,52	0,0010900	0,39730	630,2	2745,3	2115,2	1,8371	6,8414	5,0043
4,80-10 ⁵	150,30	0,0010908	0,38950	633,6	2746,3	2112,7	1,8450	6,8343	4,9892
4,90-10 ⁵	151,08	0,0010917	0,38201	636,9	2747,2	2110,3	1,8529	6,8274	4,9745
5,00-10 ⁵	151,84	0,0010926	0,37480	640,2	2748,1	2107,9	1,8606	6,8206	4,9600
5,10-10 ⁵	152,58	0,0010934	0,36787	643,4	2749,0	2105,6	1,8682	6,8139	4,9458
5,20-10 ⁵	153,32	0,0010942	0,36120	646,6	2749,9	2103,2	1,8756	6,8074	4,9318
5,30-10 ⁵	154,04	0,0010951	0,35477	649,7	2750,7	2101,0	1,8829	6,8010	4,9180
5,40-10 ⁵	154,76	0,0010959	0,34857	652,8	2751,5	2098,7	1,8901	6,7947	4,9045

p	t	v	v'	i	i'	r	s	s'	s''-s'
5,50·10 ⁵	155,46	0,0010967	0,34259	655,9	2752,3	2096,5	1,8972	6,7885	4,8913
5,60·10 ⁵	156,15	0,0010975	0,33682	658,9	2753,1	2094,2	1,9042	6,7824	4,8782
5,80·10 ⁵	157,51	0,0010991	0,32584	664,8	2754,7	2089,9	1,9179	6,7706	4,8528
6,00·10 ⁵	158,83	0,0011006	0,31558	670,5	2756,1	2085,6	1,9311	6,7592	4,8281
6,20·10 ⁵	160,12	0,0011021	0,30595	676,1	2757,6	2081,5	1,9440	6,7481	4,8041
6,40·10 ⁵	161,37	0,0011036	0,29690	681,5	2758,9	2077,4	1,9565	6,7374	4,7809
6,50·10 ⁵	161,99	0,0011044	0,29258	684,2	2759,6	2075,4	1,9626	6,7321	4,7695
6,60·10 ⁵	162,59	0,0011051	0,28839	686,9	2760,2	2073,4	1,9686	6,7269	4,7583
6,70·10 ⁵	163,19	0,0011058	0,28431	689,5	2760,9	2071,4	1,9746	6,7218	4,7472
6,80·10 ⁵	163,79	0,0011065	0,28035	692,1	2761,5	2069,5	1,9805	6,7168	4,7363
6,90·10 ⁵	164,37	0,0011073	0,27651	694,6	2762,1	2067,5	1,9863	6,7119	4,7255
7,00·10 ⁵	164,95	0,0011080	0,27276	697,1	2762,7	2065,6	1,9921	6,7070	4,7149
7,10·10 ⁵	165,53	0,0011087	0,26912	699,6	2763,3	2063,7	1,9978	6,7022	4,7044
7,20·10 ⁵	166,09	0,0011094	0,26558	702,1	2763,9	2061,8	2,0034	6,6974	4,6940
7,30·10 ⁵	166,65	0,0011101	0,26213	704,6	2764,5	2059,9	2,0089	6,6927	4,6838
7,40·10 ⁵	167,21	0,0011108	0,25877	707,0	2765,1	2058,1	2,0144	6,6881	4,6737
7,50·10 ⁵	167,76	0,0011114	0,25550	709,4	2765,6	2056,3	2,0198	6,6835	4,6637
7,60·10 ⁵	168,30	0,0011121	0,25231	711,8	2766,2	2054,4	2,0252	6,6790	4,6539
7,70·10 ⁵	168,83	0,0011128	0,24920	714,1	2766,7	2052,6	2,0305	6,6746	4,6441
7,80·10 ⁵	169,37	0,0011135	0,24617	716,4	2767,3	2050,8	2,0357	6,6702	4,6345
7,90·10 ⁵	169,89	0,0011141	0,24321	718,7	2767,8	2049,1	2,0409	6,6658	4,6250
8,00·10 ⁵	170,41	0,0011148	0,24033	721,0	2768,3	2047,3	2,0460	6,6615	4,6156
8,10·10 ⁵	170,93	0,0011154	0,23751	723,3	2768,8	2045,5	2,0511	6,6573	4,6062
8,20·10 ⁵	171,44	0,0011161	0,23476	725,5	2769,3	2043,8	2,0561	6,6531	4,5970
8,30·10 ⁵	171,95	0,0011167	0,23207	727,7	2769,8	2042,1	2,0610	6,6490	4,5879
8,40·10 ⁵	172,45	0,0011174	0,22944	729,9	2770,3	2040,4	2,0659	6,6449	4,5789
8,50·10 ⁵	172,94	0,0011180	0,22688	732,1	2770,8	2038,6	2,0708	6,6408	4,5700
8,60·10 ⁵	173,43	0,0011187	0,22437	734,3	2771,2	2037,0	2,0756	6,6368	4,5612
8,70·10 ⁵	173,92	0,0011193	0,22192	736,4	2771,7	2035,3	2,0804	6,6329	4,5525
8,80·10 ⁵	174,41	0,0011199	0,21952	738,5	2772,1	2033,6	2,0851	6,6289	4,5438
8,90·10 ⁵	174,88	0,0011206	0,21717	740,6	2772,6	2032,0	2,0898	6,6251	4,5353
9,00·10 ⁵	175,36	0,0011212	0,21487	742,7	2773,0	2030,3	2,0944	6,6212	4,5268
9,10·10 ⁵	175,83	0,0011218	0,21263	744,8	2773,5	2028,7	2,0990	6,6174	4,5185
9,20·10 ⁵	176,29	0,0011224	0,21042	746,8	2773,9	2027,1	2,1035	6,6137	4,5102
9,30·10 ⁵	176,76	0,0011230	0,20827	748,9	2774,3	2025,4	2,1080	6,6100	4,5019
9,40·10 ⁵	177,21	0,0011236	0,20616	750,9	2774,7	2023,8	2,1125	6,6063	4,4938
9,50·10 ⁵	177,67	0,0011242	0,20409	752,9	2775,2	2022,3	2,1169	6,6027	4,4857
9,60·10 ⁵	178,12	0,0011249	0,20206	754,9	2775,6	2020,7	2,1213	6,5991	4,4778
9,70·10 ⁵	178,57	0,0011255	0,20008	756,9	2776,0	2019,1	2,1256	6,5955	4,4699
9,80·10 ⁵	179,01	0,0011260	0,19813	758,8	2776,3	2017,5	2,1299	6,5919	4,4620
9,90·10 ⁵	179,45	0,0011266	0,19622	760,8	2776,7	2016,0	2,1342	6,5884	4,4542
1,00·10 ⁶	179,89	0,0011272	0,19435	762,7	2777,1	2014,4	2,1384	6,5850	4,4465
1,05·10 ⁶	182,02	0,0011301	0,18550	772,1	2779,0	2006,8	2,1591	6,5681	4,4091

p	t	v	v''	i	i''	r	s	s''	s''-s'
1,10-10 ⁶	184,07	0,0011330	0,17744	781,2	2780,7	1999,5	2,1789	6,5520	4,3731
1,15-10 ⁶	186,05	0,0011358	0,17005	790,0	2782,3	1992,3	2,1979	6,5365	4,3386
1,20-10 ⁶	187,96	0,0011385	0,16325	798,5	2783,8	1985,3	2,2163	6,5217	4,3054
1,25-10 ⁶	189,82	0,0011412	0,15698	806,8	2785,2	1978,4	2,2340	6,5074	4,2734
1,30-10 ⁶	191,61	0,0011438	0,15117	814,8	2786,5	1971,7	2,2512	6,4936	4,2425
1,35-10 ⁶	193,35	0,0011464	0,14579	822,6	2787,7	1965,2	2,2678	6,4804	4,2126
1,40-10 ⁶	195,05	0,0011489	0,14077	830,1	2788,9	1958,8	2,2839	6,4675	4,1836
1,45-10 ⁶	196,69	0,0011514	0,13608	837,5	2790,0	1952,5	2,2995	6,4551	4,1556
1,50-10 ⁶	198,30	0,0011539	0,13170	844,7	2791,0	1946,3	2,3147	6,4431	4,1284
1,55-10 ⁶	199,86	0,0011563	0,12759	851,7	2792,0	1940,2	2,3294	6,4314	4,1019
1,60-10 ⁶	201,38	0,0011587	0,12373	858,6	2792,9	1934,3	2,3438	6,4200	4,0762
1,65-10 ⁶	202,86	0,0011610	0,12010	865,3	2793,7	1928,4	2,3578	6,4090	4,0512
1,70-10 ⁶	204,31	0,0011634	0,11667	871,9	2794,5	1922,6	2,3715	6,3983	4,0268
1,7-10 ⁶	205,73	0,0011657	0,11343	878,3	2795,3	1917,0	2,3848	6,3878	4,0030
1,80-10 ⁶	207,12	0,0011679	0,11036	884,6	2796,0	1911,4	2,3978	6,3776	3,9798
1,8-10 ⁶	208,48	0,0011702	0,10746	890,8	2796,6	1905,9	2,4105	6,3676	3,9571
1,90-10 ⁶	209,81	0,0011724	0,10470	896,8	2797,3	1900,4	2,4229	6,3579	3,9350
1,95-10 ⁶	211,11	0,0011746	0,10208	902,8	2797,8	1895,1	2,4351	6,3484	3,9133
2,00-10 ⁶	212,38	0,0011768	0,09958	908,6	2798,4	1889,8	2,4470	6,3392	3,8921
2,05-10 ⁶	213,64	0,0011789	0,09720	914,4	2798,9	1884,5	2,4587	6,3301	3,8714
2,10-10 ⁶	214,87	0,0011810	0,09493	920,0	2799,4	1879,4	2,4701	6,3212	3,8511
2,15-10 ⁶	216,07	0,0011831	0,09277	925,5	2799,8	1874,3	2,4814	6,3125	3,8311
2,20-10 ⁶	217,26	0,0011852	0,09070	931,0	2800,2	1869,2	2,4924	6,3040	3,8116
2,25-10 ⁶	218,42	0,0011873	0,08871	936,3	2800,6	1864,2	2,5032	6,2956	3,7924
2,30-10 ⁶	219,56	0,0011894	0,08681	941,6	2800,9	1859,3	2,5138	6,2874	3,7736
2,35-10 ⁶	220,69	0,0011914	0,08499	946,8	2801,2	1854,4	2,5242	6,2793	3,7551
2,40-10 ⁶	221,80	0,0011934	0,08324	952,0	2801,5	1849,6	2,5344	6,2714	3,7370
2,45-10 ⁶	222,88	0,0011954	0,08156	957,0	2801,8	1844,8	2,5445	6,2636	3,7191
2,50-10 ⁶	223,96	0,0011974	0,07995	962,0	2802,0	1840,1	2,5544	6,2560	3,7015
2,55-10 ⁶	225,01	0,0011994	0,07839	966,9	2802,3	1835,4	2,5642	6,2485	3,6843
2,60-10 ⁶	226,05	0,0012014	0,07690	971,7	2802,5	1830,7	2,5738	6,2411	3,6673
2,65-10 ⁶	227,08	0,0012033	0,07546	976,5	2802,6	1826,1	2,5832	6,2338	3,6506
2,70-10 ⁶	228,09	0,0012053	0,07407	981,2	2802,8	1821,5	2,5925	6,2266	3,6341
2,75-10 ⁶	229,08	0,0012072	0,07272	985,9	2802,9	1817,0	2,6017	6,2196	3,6179
2,80-10 ⁶	230,06	0,0012091	0,07143	990,5	2803,0	1812,5	2,6107	6,2126	3,6019
2,85-10 ⁶	231,03	0,0012110	0,07018	995,0	2803,1	1808,1	2,6196	6,2058	3,5861
2,90-10 ⁶	231,99	0,0012129	0,06897	999,5	2803,2	1803,6	2,6284	6,1990	3,5706
2,95-10 ⁶	232,93	0,0012148	0,06780	1004,0	2803,2	1799,2	2,6371	6,1924	3,5553
3,00-10 ⁶	233,86	0,0012167	0,06666	1008,4	2803,3	1794,9	2,6456	6,1858	3,5402
3,10-10 ⁶	235,68	0,0012204	0,06450	1017,0	2803,3	1786,3	2,6624	6,1729	3,5105
3,20-10 ⁶	237,46	0,0012241	0,06247	1025,5	2803,2	1777,8	2,6787	6,1604	3,4817
3,30-10 ⁶	239,20	0,0012278	0,06056	1033,7	2803,1	1769,4	2,6946	6,1481	3,4535
3,40-10 ⁶	240,90	0,0012314	0,05876	1041,8	2803,0	1761,1	2,7102	6,1362	3,4260

p	t	v	v ⁻	i	i ⁻	г	s	s ⁻	s ⁻ -s ⁻
3,50-10 ⁶	242,56	0,0012350	0,05706	1049,8	2802,7	1753,0	2,7254	6,1245	3,3991
3,60-10 ⁶	244,19	0,0012385	0,05545	1057,6	2802,5	1744,9	2,7403	6,1131	3,3728
3,70-10 ⁶	245,78	0,0012421	0,05392	1065,2	2802,1	1736,9	2,7548	6,1019	3,3471
3,80-10 ⁶	247,33	0,0012456	0,05247	1072,8	2801,8	1729,0	2,7690	6,0910	3,3219
3,90-10 ⁶	248,86	0,0012491	0,05109	1080,2	2801,4	1721,2	2,7830	6,0802	3,2973
4,00-10 ⁶	250,36	0,0012526	0,04978	1087,4	2800,9	1713,5	2,7967	6,0697	3,2731
4,10-10 ⁶	251,83	0,0012560	0,04853	1094,6	2800,4	1705,8	2,8101	6,0594	3,2493
4,20-10 ⁶	253,27	0,0012595	0,04733	1101,6	2799,9	1698,2	2,8232	6,0492	3,2260
4,30-10 ⁶	254,68	0,0012629	0,04619	1108,6	2799,3	1690,7	2,8362	6,0393	3,2031
4,40-10 ⁶	256,07	0,0012663	0,04510	1115,4	2798,7	1683,2	2,8488	6,0294	3,1806
4,50-10 ⁶	257,44	0,0012697	0,04406	1122,1	2798,0	1675,9	2,8613	6,0198	3,1585
4,60-10 ⁶	258,78	0,0012730	0,04306	1128,8	2797,3	1668,5	2,8736	6,0103	3,1367
4,70-10 ⁶	260,10	0,0012764	0,04210	1135,3	2796,6	1661,2	2,8857	6,0010	3,1153
4,80-10 ⁶	261,40	0,0012797	0,04118	1141,8	2795,8	1654,0	2,8975	5,9917	3,0942
4,90-10 ⁶	262,68	0,0012831	0,04030	1148,2	2795,0	1646,8	2,9092	5,9827	3,0734
5,00-10 ⁶	263,94	0,0012864	0,03945	1154,5	2794,2	1639,7	2,9207	5,9737	3,0530
5,10-10 ⁶	265,18	0,0012897	0,03863	1160,7	2793,4	1632,7	2,9321	5,9649	3,0328
5,20-10 ⁶	266,41	0,0012930	0,03784	1166,9	2792,5	1625,6	2,9433	5,9562	3,0129
5,30-10 ⁶	267,61	0,0012963	0,03708	1173,0	2791,6	1618,6	2,9543	5,9475	2,9933
5,40-10 ⁶	268,80	0,0012996	0,03635	1179,0	2790,7	1611,7	2,9652	5,9390	2,9739
5,50-10 ⁶	269,97	0,0013029	0,03564	1184,9	2789,7	1604,8	2,9759	5,9307	2,9548
5,60-10 ⁶	271,12	0,0013062	0,03496	1190,8	2788,7	1597,9	2,9865	5,9224	2,9359
5,70-10 ⁶	272,26	0,0013095	0,03430	1196,6	2787,7	1591,1	2,9969	5,9141	2,9173
5,80-10 ⁶	273,38	0,0013127	0,03366	1202,4	2786,7	1584,3	3,0072	5,9060	6,8988
5,90-10 ⁶	274,49	0,0013160	0,03305	1208,1	2785,6	1577,6	3,0174	5,8980	2,8806
6,00-10 ⁶	275,59	0,0013193	0,03245	1213,7	2784,6	1570,8	3,0274	5,8901	2,8626
6,10-10 ⁶	276,67	0,0013225	0,03187	1219,3	2783,5	1564,1	3,0374	5,8822	2,8448
6,20-10 ⁶	277,73	0,0013258	0,03131	1224,9	2782,3	1557,5	3,0472	5,8744	2,8272
6,30-10 ⁶	278,79	0,0013291	0,03077	1230,3	2781,1	1550,8	3,0569	5,8667	2,8098
6,40-10 ⁶	279,83	0,0013323	0,03024	1235,8	2780,0	1544,2	3,0665	5,8591	2,7926
6,50-10 ⁶	280,86	0,0013356	0,02973	1241,2	2778,8	1537,7	3,0760	5,8515	2,7755
6,60-10 ⁶	281,88	0,0013388	0,02923	1246,5	2777,6	1531,1	3,0854	5,8440	2,7586
6,70-10 ⁶	282,88	0,0013421	0,02875	1251,8	2776,4	1524,6	3,0947	5,8366	2,7419
6,80-10 ⁶	283,88	0,0013453	0,02828	1257,1	2775,1	1518,1	3,1039	5,8292	2,7253
6,90-10 ⁶	284,86	0,0013486	0,02782	1262,3	2773,9	1511,6	3,1130	5,8219	2,7089
7,00-10 ⁶	285,83	0,0013519	0,02738	1267,4	2772,6	1505,1	3,1220	5,8146	2,6926
7,10-10 ⁶	286,79	0,0013551	0,02695	1272,6	2771,3	1498,7	3,1309	5,8074	2,6765
7,20-10 ⁶	287,74	0,0013584	0,02653	1277,7	2769,9	1492,3	3,1398	5,8003	2,6605
7,30-10 ⁶	288,68	0,0013617	0,02612	1282,7	2768,6	1485,9	3,1485	5,7932	2,6447
7,40-10 ⁶	289,62	0,0013649	0,02572	1287,7	2767,2	1479,5	3,1572	5,7862	2,6290
7,50-10 ⁶	290,54	0,0013682	0,02533	1292,7	2765,8	1473,1	3,1658	5,7792	2,6134
7,60-10 ⁶	291,45	0,0013715	0,02495	1297,6	2764,4	1466,8	3,1743	5,7722	2,5979
7,70-10 ⁶	292,35	0,0013748	0,02458	1302,5	2763,0	1460,4	3,1827	5,7653	2,5826

p	t	v	v ⁻	i	i ⁻	r	s	s ⁻	s ⁻ -s
7,80·10 ⁶	293,25	0,0013781	0,02422	1307,4	2761,5	1454,1	3,1911	5,7584	2,5673
7,90·10 ⁶	294,13	0,0013814	0,02387	1312,3	2760,1	1447,8	3,1994	5,7516	2,5522
8,00·10 ⁶	295,01	0,0013847	0,02353	1317,1	2758,6	1441,5	3,2077	5,7448	2,5372
8,10·10 ⁶	295,88	0,0013880	0,02319	1321,9	2757,1	1435,3	3,2158	5,7381	2,5223
8,20·10 ⁶	296,74	0,0013913	0,02286	1326,6	2755,6	1429,0	3,2239	5,7314	2,5075
8,30·10 ⁶	297,59	0,0013946	0,02254	1331,3	2754,1	1422,7	3,2320	5,7247	2,4928
8,40·10 ⁶	298,44	0,0013979	0,02223	1336,0	2752,5	1416,5	3,2399	5,7181	2,4782
8,50·10 ⁶	299,27	0,0014013	0,02193	1340,7	2751,0	1410,3	3,2478	5,7115	2,4637
8,60·10 ⁶	300,10	0,0014046	0,02163	1345,3	2749,4	1404,0	3,2557	5,7050	2,4493
8,70·10 ⁶	300,92	0,0014080	0,02133	1350,0	2747,8	1397,8	3,2635	5,6984	2,4349
8,80·10 ⁶	301,74	0,0014114	0,02105	1354,5	2746,2	1391,6	3,2712	5,6919	2,4207
8,90·10 ⁶	302,55	0,0014147	0,02077	1359,1	2744,5	1385,4	3,2789	5,6855	2,4065
9,00·10 ⁶	303,35	0,0014181	0,02049	1363,7	2742,9	1379,2	3,2866	5,6790	2,3924
9,10·10 ⁶	304,14	0,0014215	0,02022	1368,2	2741,2	1373,0	3,2942	5,6726	2,3784
9,20·10 ⁶	304,93	0,0014249	0,01996	1372,7	2739,5	1366,9	3,3017	5,6662	2,3645
9,30·10 ⁶	305,71	0,0014283	0,01970	1377,1	2737,8	1360,7	3,3092	5,6598	2,3507
9,40·10 ⁶	306,48	0,0014318	0,01945	1381,6	2736,1	1354,5	3,3166	5,6535	2,3369
9,50·10 ⁶	307,25	0,0014352	0,01920	1386,0	2734,4	1348,4	3,3240	5,6472	2,3232
9,60·10 ⁶	308,01	0,0014387	0,01896	1390,4	2732,6	1342,2	3,3313	5,6409	2,3095
9,70·10 ⁶	308,77	0,0014421	0,01872	1394,8	2730,9	1336,1	3,3386	5,6346	2,2960
9,80·10 ⁶	309,52	0,0014456	0,01849	1399,2	2729,2	1329,9	3,3459	5,6283	2,2824
9,90·10 ⁶	310,26	0,0014491	0,01826	1403,5	2727,3	1323,8	3,3531	5,6221	2,2690
1,00·10 ⁷	311,00	0,0014526	0,01803	1407,9	2725,5	1317,6	3,3603	5,6159	2,2556
1,0210 ⁷	312,46	0,0014597	0,01760	1416,5	2721,8	1305,3	3,3745	5,6035	2,2290
1,04·10 ⁷	313,90	0,0014668	0,01717	1425,0	2718,0	1293,0	3,3886	5,5912	2,2026
1,05·10 ⁷	314,61	0,0014704	0,01697	1429,3	2716,1	1286,9	3,3956	5,5850	2,1895
1,06·10 ⁷	315,31	0,0014740	0,01677	1433,5	2714,2	1280,7	3,4025	5,5789	2,1764
1,08·10 ⁷	316,71	0,0014812	0,01637	1441,9	2710,3	1268,4	3,4163	5,5667	2,1504
1,10·10 ⁷	318,08	0,0014885	0,01599	1450,3	2706,4	1256,1	3,4300	5,5545	2,1246
1,12·10 ⁷	319,44	0,0014959	0,01563	1458,6	2702,4	1243,8	3,4435	5,5424	2,0989
1,14·10 ⁷	320,77	0,0015034	0,01527	1466,8	2698,3	1231,4	3,4569	5,5303	2,0734
1,15·10 ⁷	321,44	0,0015072	0,01510	1470,9	2696,2	1225,3	3,4636	5,5243	2,0607
1,16·10 ⁷	322,09	0,0015110	0,01493	1475,0	2694,1	1219,1	3,4702	5,5182	2,0480
1,18·10 ⁷	323,39	0,0015186	0,01459	1483,2	2689,9	1206,7	3,4834	5,5062	2,0228
1,20·10 ⁷	324,68	0,0015263	0,01427	1491,3	2685,6	1194,3	3,4965	5,4941	1,9977
1,22·10 ⁷	325,95	0,0015342	0,01395	1499,4	2681,2	1181,8	3,5095	5,4821	1,9726
1,24·10 ⁷	327,20	0,0015421	0,01365	1507,5	2676,7	1169,3	3,5224	5,4700	1,9477
1,25·10 ⁷	327,82	0,0015461	0,01350	1511,5	2674,5	1163,0	3,5288	5,4640	1,9353
1,26·10 ⁷	328,43	0,0015501	0,01335	1515,5	2672,2	1156,7	3,5352	5,4580	1,9228
1,28·10 ⁷	329,65	0,0015582	0,01307	1523,4	2667,6	1144,1	3,5479	5,4459	1,8980
1,30·10 ⁷	330,86	0,0015665	0,01279	1531,4	2662,9	1131,5	3,5606	5,4339	1,8733
1,32·10 ⁷	332,05	0,0015749	0,01251	1539,3	2658,1	1118,8	3,5732	5,4218	1,8486
1,34·10 ⁷	333,22	0,0015834	0,01225	1547,2	2653,2	1106,0	3,5857	5,4097	1,8240

p	f	v	v'	i	i''	r	s	s''	s''-s'
1,35-10 ⁷	333,81	0,0015877	0,01212	1551,2	2650,8	1099,6	3,5920	5,4036	1,8116
1,36-10 ⁷	334,39	0,0015920	0,01199	1555,1	2648,3	1093,1	3,5982	5,3975	1,7993
1,38-10 ⁷	335,53	0,0016008	0,01174	1563,0	2643,2	1080,2	3,6106	5,3853	1,7747
1,40-10 ⁷	336,67	0,0016097	0,01149	1570,9	2638,1	1067,2	3,6230	5,3730	1,7500
1,42-10 ⁷	337,79	0,0016188	0,01125	1578,7	2632,9	1054,1	3,6353	5,3607	1,7254
1,44-10 ⁷	338,90	0,0016281	0,01101	1586,6	2627,5	1040,9	3,6477	5,3484	1,7007
1,45-10 ⁷	339,45	0,0016328	0,01090	1590,5	2624,8	1034,3	3,6538	5,3422	1,6884
1,46-10 ⁷	340,00	0,0016375	0,01078	1594,4	2622,1	1027,6	3,6599	5,3359	1,6760
1,48-10 ⁷	341,08	0,0016471	0,01056	1602,3	2616,5	1014,2	3,6722	5,3234	1,6512
1,50-10 ⁷	342,16	0,0016570	0,01034	1610,2	2610,9	1000,7	3,6844	5,3108	1,6264
1,52-10 ⁷	343,22	0,0016670	0,010125	1618,0	2605,1	987,1	3,6967	5,2981	1,6014
1,54-10 ⁷	344,27	0,0016773	0,009915	1625,9	2599,2	973,3	3,7089	5,2853	1,5764
1,55-10 ⁷	344,79	0,0016825	0,009811	1629,9	2596,2	966,4	3,7150	5,2789	1,5638
1,56-10 ⁷	345,31	0,0016878	0,009709	1633,8	2593,2	959,4	3,7212	5,2724	1,5513
1,57-10 ⁷	345,83	0,0016931	0,009607	1637,8	2590,1	952,4	3,7273	5,2659	1,5386
1,58-10 ⁷	346,34	0,0016985	0,009506	1641,7	2587,1	945,3	3,7334	5,2594	1,5260
1,59-10 ⁷	346,85	0,0017040	0,009407	1645,7	2584,0	938,3	3,7395	5,2529	1,5133
1,60-10 ⁷	347,36	0,0017095	0,009308	1649,7	2580,8	931,1	3,7457	5,2463	1,5006
1,61-10 ⁷	347,86	0,0017151	0,009210	1653,7	2577,6	924,0	3,7518	5,2397	1,4878
1,62-10 ⁷	348,36	0,0017208	0,009114	1657,6	2574,4	916,8	3,7578	5,2330	1,4750
1,63-10 ⁷	348,86	0,0017266	0,009018	1661,7	2571,2	909,5	3,7641	5,2263	1,4622
1,64-10 ⁷	349,36	0,0017324	0,008923	1665,7	2567,9	902,2	3,7703	5,2196	1,4493
1,65-10 ⁷	349,86	0,0017383	0,008828	1669,7	2564,6	894,9	3,7765	5,2129	1,4364
1,66-10 ⁷	350,35	0,0017444	0,008736	1673,7	2561,2	887,5	3,7827	5,2061	1,4234
1,67-10 ⁷	350,84	0,0017505	0,008643	1677,8	2557,9	880,1	3,7889	5,1993	1,4104
1,68-10 ⁷	351,33	0,0017567	0,008551	1681,9	2554,4	872,6	3,7952	5,1924	1,3973
1,69-10 ⁷	351,81	0,0017630	0,008460	1685,9	2551,0	865,0	3,8014	5,1855	1,3841
1,70-10 ⁷	352,29	0,0017693	0,008370	1690,0	2547,4	857,4	3,8077	5,1785	1,3709
1,71-10 ⁷	352,77	0,0017758	0,008280	1694,1	2543,8	849,7	3,8140	5,1715	1,3575
1,72-10 ⁷	353,25	0,0017824	0,008190	1698,3	2540,2	842,0	3,8203	5,1644	1,3441
1,73-10 ⁷	353,73	0,0017891	0,008102	1702,4	2536,6	834,2	3,8266	5,1572	1,3307
1,74-10 ⁷	354,20	0,0017959	0,008014	1706,6	2532,9	826,3	3,8329	5,1501	1,3171
1,75-10 ⁷	354,67	0,0018029	0,007927	1710,8	2529,1	818,4	3,8393	5,1428	1,3035
1,76-10 ⁷	355,14	0,0018099	0,007840	1715,0	2525,3	810,3	3,8457	5,1355	1,2898
1,77-10 ⁷	355,61	0,0018171	0,007754	1719,2	2521,4	802,3	3,8522	5,1281	1,2759
1,78-10 ⁷	356,07	0,0018244	0,007668	1723,4	2517,5	794,1	3,8586	5,1206	1,2620
1,79-10 ⁷	356,53	0,0018319	0,007583	1727,7	2513,6	785,8	3,8651	5,1131	1,2480
1,80-10 ⁷	356,99	0,0018395	0,007499	1732,0	2509,5	777,5	3,8717	5,1055	1,2339
1,81-10 ⁷	357,45	0,0018473	0,007414	1736,4	2505,4	769,1	3,8783	5,0979	1,2196
1,82-10 ⁷	357,90	0,0018552	0,007331	1740,7	2501,3	760,6	3,8849	5,0901	1,2052
1,83-10 ⁷	358,36	0,0018633	0,007247	1745,1	2497,1	752,0	3,8915	5,0823	1,1907
1,84-10 ⁷	358,81	0,0018715	0,007164	1749,5	2492,8	743,2	3,8982	5,0743	1,1761
1,85-10 ⁷	359,26	0,0018800	0,007082	1754,0	2488,4	734,4	3,9050	5,0663	1,1613

p	t	v	v''	i	i''	r	s	s''	s''-s'
1,86·10 ⁷	359,70	0,0018887	0,006999	1758,5	2484,0	725,5	3,9118	5,0582	1,1464
1,87·10 ⁷	360,15	0,0018975	0,006917	1763,0	2479,5	716,4	3,9187	5,0500	1,1313
1,88·10 ⁷	360,59	0,0019066	0,006836	1767,6	2474,9	707,3	3,9256	5,0416	1,1160
1,89·10 ⁷	361,03	0,0019159	0,006754	1772,2	2470,2	698,0	3,9326	5,0332	1,1006
1,90·10 ⁷	361,47	0,0019255	0,006673	1776,9	2465,4	688,5	3,9396	5,0246	1,0849
1,91·10 ⁷	361,91	0,0019353	0,006591	1781,6	2460,5	678,9	3,9468	5,0159	1,0691
1,92·10 ⁷	362,34	0,0019454	0,006510	1786,4	2455,6	669,2	3,9540	5,0070	1,0530
1,93·10 ⁷	362,77	0,0019557	0,006429	1791,2	2450,5	659,3	3,9613	4,9980	1,0367
1,94·10 ⁷	363,20	0,0019664	0,006348	1796,1	2445,3	649,2	3,9687	4,9889	1,0202
1,95·10 ⁷	363,63	0,0019775	0,006267	1801,1	2440,0	638,9	3,9762	4,9795	1,0034
1,96·10 ⁷	364,06	0,0019889	0,006186	1806,1	2434,6	628,5	3,9838	4,9700	0,9863
1,97·10 ⁷	364,48	0,0020006	0,006104	1811,2	2429,0	617,8	3,9915	4,9603	0,9689
1,98·10 ⁷	364,91	0,002013	0,006023	1816,4	2423,3	606,9	3,9993	4,9504	0,9511
1,99·10 ⁷	365,33	0,002026	0,005941	1821,7	2417,5	595,7	4,0073	4,9403	0,9331
2,00·10 ⁷	365,75	0,002039	0,005859	1827,1	2411,4	584,3	4,0154	4,9300	0,9146
2,01·10 ⁷	366,16	0,002052	0,005776	1832,6	2405,2	572,6	4,0237	4,9193	0,8956
2,02·10 ⁷	366,58	0,002067	0,005692	1838,2	2398,8	560,6	4,0321	4,9083	0,8762
2,03·10 ⁷	366,99	0,002082	0,005608	1844,0	2392,1	548,2	4,0408	4,8971	0,8563
2,04·10 ⁷	367,40	0,002097	0,005523	1849,8	2385,3	535,4	4,0496	4,8855	0,8359
2,05·10 ⁷	367,81	0,002114	0,005438	1855,9	2378,2	522,3	4,0588	4,8736	0,8148
2,06·10 ⁷	368,22	0,002131	0,005351	1862,1	2370,8	508,6	4,0681	4,8612	0,7931
2,07·10 ⁷	368,62	0,002149	0,005263	1868,6	2363,0	494,5	4,0778	4,8483	0,7705
2,08·10 ⁷	369,03	0,002169	0,005173	1875,2	2355,0	479,8	4,0879	4,8349	0,7471
2,09·10 ⁷	369,43	0,002190	0,005082	1882,1	2346,5	464,3	4,0983	4,8209	0,7226
2,10·10 ⁷	369,83	0,002212	0,004988	1889,4	2337,6	448,2	4,1092	4,8063	0,6970
2,11·10 ⁷	370,22	0,002236	0,004891	1897,0	2328,1	431,1	4,1207	4,7908	0,6700
2,12·10 ⁷	370,62	0,002262	0,004792	1905,0	2318,0	413,0	4,1328	4,7746	0,6418
2,13·10 ⁷	371,01	0,002291	0,004690	1913,6	2307,3	393,7	4,1458	4,7570	0,6112
2,14·10 ⁷	371,41	0,002324	0,004581	1922,8	2295,5	372,7	4,1597	4,7380	0,5783
2,15·10 ⁷	371,80	0,002360	0,004466	1932,8	2282,6	349,8	4,1749	4,7172	0,5423
2,16·10 ⁷	372,18	0,002402	0,004343	1944,0	2268,1	324,1	4,1918	4,6942	0,5024
2,17·10 ⁷	372,57	0,002453	0,004207	1956,7	2251,6	294,1	4,2112	4,6679	0,4567
2,18·10 ⁷	372,95	0,002517	0,004053	1971,9	2231,9	260,0	4,2343	4,6367	0,4024
2,19·10 ⁷	373,33	0,002604	0,003868	1991,4	2206,8	215,4	4,2641	4,5973	0,3332
2,20·10 ⁷	373,71	0,002750	0,003609	2021,9	2169,2	147,3	4,3109	4,5386	0,2278
2,206·10 ⁷	373,95	0,003106	0,003106	2087,5	2087,5	0,0	4,4120	4,4120	0,0

Kritik vaziyat ko'rsatkichi:

Bosim, MPa.....	22,064
Harorat, °C	373,946
Solishtirma hajm, m ³ /kg	0,003106
Solishtirma entalpiya, kJ/kg.....	2087,5
Solishtirma entropiya, kJ/(kg·°K).....	4,4120

Suv va qaynagan bug' termodinamik xususiyati

t	p = 1 κПа t _g = 6,98			p = 2 κПа t _g = 17,51			p = 3 κПа t _g = 24,08			p = 4 κПа t _g = 28,96		
	v [*] = 129,18	i [*] = 2513,7	s [*] = 8,9749	v [*] = 66,99	i [*] = 2533,9	s [*] = 8,7227	v [*] = 45,66	i [*] = 2544,9	s [*] = 8,5766	v [*] = 34,79	i [*] = 2553,7	s [*] = 8,4735
	v	i	s	v	i	s	v	i	s	v	i	s
0	0,0010002	0,0	-0,0002	0,0010002	0,0	-0,0002	0,0010002	0,0	-0,0002	0,0010002	0,0	-0,0002
10	130,59	2519,4	8,9953	0,0010003	42,0	0,1511	0,0010003	42,0	0,1511	0,0010003	42,0	0,1511
20	135,22	2538,2	9,0604	67,57	2537,7	8,7390	0,0010018	83,9	0,2965	0,0010018	83,9	0,2965
30	139,85	2556,9	9,1233	69,89	2556,5	8,8023	46,57	2556,1	8,6141	34,91	2555,7	8,4801
40	144,47	2575,7	9,1841	72,21	2575,3	8,8634	48,12	2575,0	8,6754	36,08	2574,7	8,5418
50	149,10	2594,4	9,2430	74,53	2594,1	8,9224	49,67	2593,9	8,7347	37,24	2593,6	8,6012
60	153,72	2613,2	9,3002	76,84	2613,0	8,9798	51,21	2612,7	8,7921	38,40	2612,5	8,6588
70	158,34	2632,0	9,3558	79,15	2631,8	9,0354	52,76	2631,6	8,8479	39,56	2631,4	8,7146
80	162,96	2650,8	9,4099	81,46	2650,6	9,0896	54,30	2650,5	8,9021	40,72	2650,3	8,7689
90	167,58	2669,6	9,4625	83,77	2669,5	9,1423	55,84	2669,4	8,9549	41,87	2669,2	8,8218
100	172,19	2688,5	9,5138	86,08	2688,4	9,1937	57,38	2688,3	9,0063	43,03	2688,2	8,8732
110	176,81	2707,5	9,5639	88,39	2707,4	9,2438	58,92	2707,3	9,0564	44,19	2707,1	8,9234
120	181,43	2726,4	9,6128	90,70	2726,3	9,2927	60,46	2726,3	9,1054	45,34	2726,2	8,9724
130	186,05	2745,5	9,6606	93,01	2745,4	9,3405	62,00	2745,3	9,1532	46,50	2745,2	9,0203
140	190,66	2764,5	9,7073	95,32	2764,5	9,3872	63,54	2764,4	9,2000	47,65	2764,3	9,0670
150	195,28	2783,6	9,7530	97,63	2783,6	9,4330	65,08	2783,5	9,2457	48,81	2783,4	9,1128
160	199,90	2802,8	9,7978	99,94	2802,7	9,4777	66,62	2802,7	9,2905	49,96	2802,6	9,1576
170	204,51	2822,0	9,8416	102,25	2822,0	9,5216	68,16	2821,9	9,3344	51,12	2821,9	9,2015
180	209,13	2841,3	9,8846	104,56	2841,2	9,5646	69,70	2841,2	9,3774	52,27	2841,1	9,2445
190	213,74	2860,6	9,9268	106,87	2860,6	9,6068	71,24	2860,5	9,4196	53,43	2860,5	9,2867
200	218,36	2880,0	9,9682	109,17	2880,0	9,6482	72,78	2879,9	9,4610	54,58	2879,9	9,3282
210	222,98	2899,4	10,0088	111,48	2899,4	9,6889	74,32	2899,3	9,5017	55,74	2899,3	9,3688
220	227,59	2918,9	10,0488	113,79	2918,9	9,7288	75,86	2918,8	9,5416	56,89	2918,8	9,4088
230	232,21	2938,5	10,0880	116,10	2938,4	9,7680	77,40	2938,4	9,5809	58,04	2938,4	9,4480
240	236,82	2958,1	10,1266	118,41	2958,0	9,8066	78,94	2958,0	9,6194	59,20	2958,0	9,4866
250	241,44	2977,7	10,1645	120,72	2977,7	9,8446	80,47	2977,7	9,6574	60,35	2977,6	9,5246
260	246,05	2997,5	10,2019	123,02	2997,4	9,8819	82,01	2997,4	9,6948	61,51	2997,4	9,5619
270	250,67	3017,2	10,2386	125,33	3017,2	9,9187	83,55	3017,2	9,7315	62,66	3017,2	9,5987
280	255,29	3037,1	10,2748	127,64	3037,1	9,9549	85,09	3037,0	9,7677	63,82	3037,0	9,6349
290	259,90	3057,0	10,3105	129,95	3057,0	9,9906	86,63	3056,9	9,8034	64,97	3056,9	9,6706
300	264,52	3077,0	10,3456	132,26	3076,9	10,0257	88,17	3076,9	9,8385	66,12	3076,9	9,7057
310	269,13	3097,0	10,3803	134,56	3097,0	10,0603	89,71	3096,9	9,8732	67,28	3096,9	9,7404
320	273,75	3117,1	10,4144	136,87	3117,0	10,0945	91,25	3117,0	9,9073	68,43	3117,0	9,7745
330	278,36	3137,2	10,4481	139,18	3137,2	10,1282	92,78	3137,2	9,9410	69,59	3137,2	9,8082
340	282,98	3157,4	10,4814	141,49	3157,4	10,1614	94,32	3157,4	9,9743	70,74	3157,4	9,8415
350	287,59	3177,7	10,5142	143,79	3177,7	10,1943	95,86	3177,7	10,0071	71,89	3177,7	9,8743
360	292,21	3198,1	10,5466	146,10	3198,0	10,2266	97,40	3198,0	10,0395	73,05	3198,0	9,9067
370	296,83	3218,5	10,5785	148,41	3218,4	10,2586	98,94	3218,4	10,0715	74,20	3218,4	9,9387
380	301,44	3238,9	10,6101	150,72	3238,9	10,2902	100,48	3238,9	10,1031	75,36	3238,9	9,9703
390	306,06	3259,5	10,6413	153,03	3259,5	10,3214	102,02	3259,4	10,1343	76,51	3259,4	10,0015

400	310,67	3280,1	10,6722	155,33	3280,1	10,3522	103,55	3280,0	10,1651	77,67	3280,0	10,0323
410	315,29	3300,7	10,7026	157,64	3300,7	10,3827	105,09	3300,7	10,1956	78,82	3300,7	10,0628
420	319,90	3321,5	10,7328	159,95	3321,5	10,4129	106,63	3321,4	10,2257	79,97	3321,4	10,0929
430	324,52	3342,3	10,7626	162,26	3342,3	10,4426	108,17	3342,3	10,2555	81,13	3342,2	10,1227
440	329,13	3363,1	10,7920	164,57	3363,1	10,4721	109,71	3363,1	10,2850	82,28	3363,1	10,1522
450	333,75	3384,1	10,8212	166,87	3384,1	10,5013	111,25	3384,1	10,3141	83,43	3384,0	10,1813
460	338,36	3405,1	10,8500	169,18	3405,1	10,5301	112,79	3405,1	10,3430	84,59	3405,0	10,2102
470	342,98	3426,2	10,8786	171,49	3426,1	10,5587	114,32	3426,1	10,3715	85,74	3426,1	10,2387
480	347,60	3447,3	10,9068	173,80	3447,3	10,5869	115,86	3447,3	10,3998	86,90	3447,3	10,2670
490	352,21	3468,5	10,9348	176,10	3468,5	10,6149	117,40	3468,5	10,4277	88,05	3468,5	10,2950
500	356,83	3489,8	10,9625	178,41	3489,8	10,6426	118,94	3489,7	10,4554	89,20	3489,7	10,3227
510	361,44	3511,1	10,9899	180,72	3511,1	10,6700	120,48	3511,1	10,4829	90,36	3511,1	10,3501
520	366,06	3532,5	11,0171	183,03	3532,5	10,6972	122,02	3532,5	10,5100	91,51	3532,5	10,3773
530	370,67	3554,0	11,0440	185,33	3554,0	10,7241	123,56	3554,0	10,5370	92,67	3554,0	10,4042
540	375,29	3575,6	11,0707	187,64	3575,6	10,7508	125,09	3575,5	10,5636	93,82	3575,5	10,4308

3-jadval (davomi)

t	$p = 1 \text{ kfta}$ $t_5 = 6,98$				$p = 2 \text{ kfta}$ $t_5 = 17,51$				$p = 3 \text{ kfta}$ $t_5 = 24,08$				$p = 4 \text{ kfta}$ $t_5 = 28,96$			
	$u'' =$	$\bar{r}'' =$	$s'' =$	$\bar{r}'' =$	$u'' =$	$\bar{r}'' =$	$s'' =$	$\bar{r}'' =$	$u'' =$	$\bar{r}'' =$	$s'' =$	$\bar{r}'' =$	$u'' =$	$\bar{r}'' =$	$s'' =$	
	129,18	2513,7	8,9749	66,99	2533,9	8,7227	45,66	2544,9	8,5766	34,79	2553,7	8,4735				
u	i	s	u	i	s	u	i	s	u	i	s	u	i	s		
550	379,90	3597,2	11,0971	189,95	3597,2	10,7772	126,63	3597,2	10,5900	94,97	3597,2	10,4573				
560	384,52	3618,9	11,1233	192,26	3618,9	10,8034	128,17	3618,9	10,6162	96,13	3618,8	10,4835				
570	389,13	3640,6	11,1493	194,57	3640,6	10,8293	129,71	3640,6	10,6422	97,28	3640,6	10,5094				
580	393,75	3662,5	11,1750	196,87	3662,5	10,8551	131,25	3662,4	10,6679	98,44	3662,4	10,5352				
590	398,36	3684,4	11,2005	199,18	3684,4	10,8806	132,79	3684,4	10,6935	99,59	3684,3	10,5607				
600	402,98	3706,3	11,2258	201,49	3706,3	10,9059	134,33	3706,3	10,7188	100,74	3706,3	10,5860				
610	407,59	3728,4	11,2509	203,80	3728,4	10,9310	135,86	3728,4	10,7439	101,90	3728,4	10,6111				
620	412,21	3750,5	11,2758	206,10	3750,5	10,9559	137,40	3750,5	10,7688	103,05	3750,5	10,6360				
630	416,83	3772,7	11,3005	208,41	3772,7	10,9806	138,94	3772,7	10,7935	104,21	3772,7	10,6607				
640	421,44	3794,9	11,3250	210,72	3794,9	11,0051	140,48	3794,9	10,8180	105,36	3794,9	10,6852				
650	426,06	3817,3	11,3494	213,03	3817,3	11,0294	142,02	3817,3	10,8423	106,51	3817,2	10,7095				
660	430,67	3839,7	11,3735	215,33	3839,7	11,0536	143,56	3839,6	10,8664	107,67	3839,6	10,7337				
670	435,29	3862,1	11,3974	217,64	3862,1	11,0775	145,09	3862,1	10,8904	108,82	3862,1	10,7576				
680	439,90	3884,7	11,4212	219,95	3884,7	11,1013	146,63	3884,7	10,9142	109,97	3884,7	10,7814				
690	444,52	3907,3	11,4448	222,26	3907,3	11,1249	148,17	3907,3	10,9378	111,13	3907,3	10,8050				
700	449,13	3930,0	11,4682	224,57	3930,0	11,1483	149,71	3929,9	10,9612	112,28	3929,9	10,8284				
710	453,75	3952,7	11,4915	226,87	3952,7	11,1716	151,25	3952,7	10,9845	113,44	3952,7	10,8517				
720	458,36	3975,5	11,5146	229,18	3975,5	11,1947	152,79	3975,5	11,0075	114,59	3975,5	10,8748				
730	462,98	3998,4	11,5375	231,49	3998,4	11,2176	154,33	3998,4	11,0305	115,74	3998,4	10,8977				
740	467,59	4021,4	11,5603	233,80	4021,4	11,2404	155,86	4021,4	11,0533	116,90	4021,4	10,9205				
750	472,21	4044,4	11,5829	236,10	4044,4	11,2630	157,40	4044,4	11,0759	118,05	4044,4	10,9431				
760	476,82	4067,5	11,6054	238,41	4067,5	11,2855	158,94	4067,5	11,0984	119,21	4067,5	10,9656				
770	481,44	4090,7	11,6277	240,72	4090,7	11,3078	160,48	4090,7	11,1207	120,36	4090,7	10,9879				
780	486,06	4114,0	11,6499	243,03	4113,9	11,3300	162,02	4113,9	11,1429	121,51	4113,9	11,0101				
790	490,67	4137,3	11,6719	245,33	4137,3	11,3520	163,56	4137,3	11,1649	122,67	4137,3	11,0321				
800	495,29	4160,7	11,6938	247,64	4160,7	11,3739	165,09	4160,7	11,1868	123,82	4160,6	11,0540				
810	499,90	4184,1	11,7156	249,95	4184,1	11,3957	166,63	4184,1	11,2086	124,97	4184,1	11,0758				
820	504,52	4207,7	11,7373	252,26	4207,7	11,4173	168,17	4207,7	11,2302	126,13	4207,7	11,0974				
830	509,13	4231,3	11,7588	254,57	4231,3	11,4388	169,71	4231,3	11,2517	127,28	4231,3	11,1189				
840	513,75	4255,0	11,7801	256,87	4255,0	11,4602	171,25	4255,0	11,2731	128,44	4255,0	11,1403				
850	518,36	4278,7	11,8013	259,18	4278,7	11,4814	172,79	4278,7	11,2943	129,59	4278,7	11,1615				
860	522,98	4302,5	11,8225	261,49	4302,5	11,5025	174,33	4302,5	11,3154	130,74	4302,5	11,1826				
870	527,59	4326,4	11,8434	263,80	4326,4	11,5235	175,86	4326,4	11,3364	131,90	4326,4	11,2036				
880	532,21	4350,3	11,8643	266,10	4350,3	11,5444	177,40	4350,3	11,3572	133,05	4350,3	11,2245				
890	536,82	4374,3	11,8850	268,41	4374,3	11,5651	178,94	4374,3	11,3780	134,21	4374,3	11,2452				
900	541,44	4398,4	11,9056	270,72	4398,4	11,5857	180,48	4398,4	11,3986	135,36	4398,4	11,2658				
910	546,05	4422,6	11,9261	273,03	4422,6	11,6062	182,02	4422,6	11,4191	136,51	4422,5	11,2863				

920	550,67	4446,8	11,9465	275,33	4446,8	11,6266	183,56	4446,8	11,4394	137,67	4446,8	11,3067
930	555,28	4471,0	11,9668	277,64	4471,0	11,6468	185,09	4471,0	11,4597	138,82	4471,0	11,3269
940	559,90	4495,4	11,9869	279,95	4495,4	11,6670	186,63	4495,4	11,4799	139,97	4495,4	11,3471
950	564,52	4519,8	12,0069	282,26	4519,8	11,6870	188,17	4519,8	11,4999	141,13	4519,8	11,3671
960	569,13	4544,3	12,0269	284,56	4544,3	11,7070	189,71	4544,3	11,5198	142,28	4544,3	11,3870
970	573,75	4568,8	12,0467	286,87	4568,8	11,7268	191,25	4568,8	11,5396	143,44	4568,8	11,4069
980	578,36	4593,4	12,0664	289,18	4593,4	11,7465	192,79	4593,4	11,5594	144,59	4593,4	11,4266
990	582,98	4618,1	12,0860	291,49	4618,1	11,7661	194,33	4618,1	11,5790	145,74	4618,1	11,4462
1000	587,59	4642,8	12,1055	293,80	4642,8	11,7856	195,86	4642,8	11,5985	146,90	4642,8	11,4657

3-jadval (davomi)

t	$p = 5 \text{ kdla}$ $t_0 = 32,88$				$p = 6 \text{ kdla}$ $t_0 = 36,16$				$p = 7 \text{ kdla}$ $t_0 = 39,00$				$p = 8 \text{ kdla}$ $t_0 = 41,51$			
	$v'' = 29,18$	$v'' = 2560,8$	$v'' = 8,3939$	$v'' = 23,734$	$v'' = 2566,7$	$v'' = 8,3291$	$v'' = 20,525$	$v'' = 2571,8$	$v'' = 8,2746$	$v'' = 18,009$	$v'' = 2576,2$	$v'' = 8,2274$	$v'' = 16,809$	$v'' = 2576,2$	$v'' = 8,2274$	
	v	i	s	i	s	i	s	i	s	i	s	i	s	i	s	
0	0,0010002	0,0	-0,0002	0,0010002	0,0	-0,0002	0,0010002	0,0	-0,0002	0,0010002	0,0	-0,0002	0,0010002	0,0	-0,0002	
10	0,0010003	42,0	0,1511	0,0010003	42,0	0,1511	0,0010003	42,0	0,1511	0,0010003	42,0	0,1511	0,0010003	42,0	0,1511	
20	0,0010018	83,9	0,2965	0,0010018	83,9	0,2965	0,0010018	83,9	0,2965	0,0010018	83,9	0,2965	0,0010018	83,9	0,2965	
30	0,0010044	125,7	0,4368	0,0010044	125,7	0,4368	0,0010044	125,7	0,4368	0,0010044	125,7	0,4368	0,0010044	125,7	0,4368	
40	28,85	2574,4	8,4379	24,03	2574,0	8,3528	20,59	2573,7	8,2807	0,0010079	167,5	0,5724				
50	29,78	2593,4	8,4976	24,81	2593,1	8,4127	21,26	2592,8	8,3409	18,60	2592,6	8,2786				
60	30,71	2612,3	8,5553	25,59	2612,1	8,4706	21,93	2611,9	8,3989	19,18	2611,6	8,3367				
70	31,64	2631,2	8,6112	26,36	2631,0	8,5266	22,59	2630,8	8,4550	19,76	2630,6	8,3930				
80	32,57	2650,1	8,6656	27,13	2650,0	8,5811	23,25	2649,8	8,5096	20,34	2649,7	8,4476				
90	33,49	2669,1	8,7185	27,91	2668,9	8,6340	23,92	2668,8	8,5626	20,92	2668,7	8,5006				
100	28,68	34,42	2688,0	8,7700	2687,9	8,6856	24,58	2687,8	8,6142	21,50	2687,7	8,5523				
110	29,45	35,34	2707,0	8,8202	2706,9	8,7358	25,24	2706,8	8,6645	22,08	2706,7	8,6026				
120	30,22	36,27	2726,1	8,8692	2726,0	8,7849	25,90	2725,9	8,7136	22,66	2725,8	8,6517				
130	30,99	37,19	2745,1	8,9171	2745,0	8,8328	26,56	2745,0	8,7615	23,24	2744,9	8,6997				
140	31,76	38,12	2764,2	8,9639	2764,1	8,8796	27,22	2764,1	8,8083	23,82	2764,0	8,7466				
150	39,04	2783,4	9,0097	32,53	2783,3	8,9254	27,88	2783,2	8,8541	24,40	2783,2	8,7924				
160	39,97	2802,6	9,0545	33,30	2802,5	8,9703	28,54	2802,4	8,8990	24,97	2802,4	8,8373				
170	40,89	2821,8	9,0984	34,07	2821,7	9,0142	29,20	2821,7	8,9429	25,55	2821,6	8,8812				
180	41,82	2841,1	9,1415	34,84	2841,0	9,0572	29,86	2841,0	8,9860	26,13	2840,9	8,9243				
190	42,74	2860,4	9,1837	35,61	2860,4	9,0995	30,52	2860,3	9,0282	26,71	2860,3	8,9665				
200	43,66	2879,8	9,2251	36,38	2879,8	9,1409	31,18	2879,7	9,0697	27,29	2879,7	9,0080				
210	44,59	2899,3	9,2658	37,15	2899,2	9,1816	31,84	2899,2	9,1104	27,86	2899,1	9,0487				
220	45,51	2918,8	9,3057	37,92	2918,7	9,2215	32,50	2918,7	9,1503	28,44	2918,6	9,0886				
230	46,43	2938,3	9,3450	38,69	2938,3	9,2608	33,16	2938,2	9,1896	29,02	2938,2	9,1279				
240	47,36	2957,9	9,3836	39,46	2957,9	9,2994	33,82	2957,9	9,2282	29,60	2957,8	9,1665				
250	48,28	2977,6	9,4216	40,23	2977,6	9,3374	34,48	2977,5	9,2662	30,17	2977,5	9,2045				
260	49,20	2997,3	9,4589	41,00	2997,3	9,3747	35,14	2997,3	9,3035	30,75	2997,2	9,2419				
270	50,13	3017,1	9,4957	41,77	3017,1	9,4115	35,80	3017,1	9,3403	31,33	3017,0	9,2786				
280	51,05	3037,0	9,5319	42,54	3036,9	9,4477	36,46	3036,9	9,3765	31,90	3036,9	9,3149				
290	51,97	3056,9	9,5676	43,31	3056,9	9,4834	37,12	3056,8	9,4122	32,48	3056,8	9,3505				
300	52,90	3076,9	9,6027	44,08	3076,8	9,5185	37,78	3076,8	9,4474	33,06	3076,8	9,3857				
310	53,82	3096,9	9,6374	44,85	3096,9	9,5532	38,44	3096,8	9,4820	33,64	3096,8	9,4204				
320	54,75	3117,0	9,6715	45,62	3117,0	9,5874	39,10	3116,9	9,5162	34,21	3116,9	9,4545				
330	55,67	3137,1	9,7052	46,39	3137,1	9,6211	39,76	3137,1	9,5499	34,79	3137,1	9,4882				
340	56,59	3157,4	9,7385	47,16	3157,3	9,6543	40,42	3157,3	9,5831	35,37	3157,3	9,5215				
350	57,51	3177,6	9,7713	47,93	3177,6	9,6871	41,08	3177,6	9,6160	35,94	3177,6	9,5543				
360	58,44	3198,0	9,8037	48,70	3198,0	9,7195	41,74	3197,9	9,6483	36,52	3197,9	9,5867				
370	59,36	3218,4	9,8357	49,47	3218,4	9,7515	42,40	3218,4	9,6803	37,10	3218,3	9,6187				
380	60,28	3238,9	9,8673	50,24	3238,9	9,7831	43,06	3238,8	9,7119	37,68	3238,8	9,6503				
390	61,21	3259,4	9,8985	51,01	3259,4	9,8143	43,72	3259,4	9,7431	38,25	3259,4	9,6815				
400	62,13	3280,0	9,9293	51,78	3280,0	9,8451	44,38	3280,0	9,7740	38,83	3280,0	9,7123				
410	63,05	3300,7	9,9598	52,54	3300,7	9,8756	45,04	3300,7	9,8045	39,41	3300,6	9,7428				
420	63,98	3321,4	9,9899	53,31	3321,4	9,9058	45,70	3321,4	9,8346	39,98	3321,4	9,7730				
430	64,90	3342,2	10,0197	54,08	3342,2	9,9356	46,36	3342,2	9,8644	40,56	3342,2	9,8032				
440	65,82	3363,1	10,0492	54,85	3363,1	9,9650	47,02	3363,1	9,8939	41,14	3363,1	9,8322				
450	66,75	3384,0	10,0783	55,62	3384,0	9,9942	47,68	3384,0	9,9230	41,72	3384,0	9,8614				
460	67,67	3405,0	10,1072	56,39	3405,0	10,0230	48,34	3405,0	9,9519	42,29	3405,0	9,8902				
470	68,59	3426,1	10,1357	57,16	3426,1	10,0516	48,99	3426,1	9,9804	42,87	3426,1	9,9188				

480	69,52	3447,2	10,1640	57,93	3447,2	10,0798	49,65	3447,2	10,0087	43,45	3447,2	9,9470
490	70,44	3468,5	10,1920	58,70	3468,4	10,1078	50,31	3468,4	10,0366	44,02	3468,4	9,9750
500	71,36	3489,7	10,2197	59,47	3489,7	10,1355	50,97	3489,7	10,0643	44,60	3489,7	10,0027
510	72,29	3511,1	10,2471	60,24	3511,1	10,1629	51,63	3511,1	10,0918	45,18	3511,0	10,0301
520	73,21	3532,5	10,2743	61,01	3532,5	10,1901	52,29	3532,5	10,1189	45,75	3532,5	10,0573
530	74,13	3554,0	10,3012	61,78	3554,0	10,2170	52,95	3554,0	10,1459	46,33	3553,9	10,0842
540	75,06	3575,5	10,3278	62,55	3575,5	10,2437	53,61	3575,5	10,1725	46,91	3575,5	10,1109
550	75,98	3597,1	10,3543	63,32	3597,1	10,2701	54,27	3597,1	10,1990	47,49	3597,1	10,1373
560	76,90	3618,8	10,3805	64,08	3618,8	10,2963	54,93	3618,8	10,2252	48,06	3618,8	10,1635
570	77,83	3640,6	10,4064	64,85	3640,6	10,3223	55,59	3640,6	10,2511	48,64	3640,6	10,1895
580	78,75	3662,4	10,4322	65,62	3662,4	10,3480	56,25	3662,4	10,2769	49,22	3662,4	10,2152
590	79,67	3684,3	10,4577	66,39	3684,3	10,3735	56,91	3684,3	10,3024	49,79	3684,3	10,2408
600	80,59	3706,3	10,4830	67,16	3706,3	10,3989	57,57	3706,3	10,3277	50,37	3706,3	10,2661
610	81,52	3728,4	10,5081	67,93	3728,3	10,4240	58,23	3728,3	10,3528	50,95	3728,3	10,2912
620	82,44	3750,5	10,5330	68,70	3750,5	10,4489	58,89	3750,5	10,3777	51,52	3750,4	10,3161
630	83,36	3772,7	10,5577	69,47	3772,6	10,4736	59,55	3772,6	10,4024	52,10	3772,6	10,3408
640	84,29	3794,9	10,5822	70,24	3794,9	10,4981	60,20	3794,9	10,4269	52,68	3794,9	10,3653
650	85,21	3817,2	10,6065	71,01	3817,2	10,5224	60,86	3817,2	10,4512	53,26	3817,2	10,3896
660	86,13	3839,6	10,6307	71,78	3839,6	10,5465	61,52	3839,6	10,4754	53,83	3839,6	10,4137
670	87,06	3862,1	10,6546	72,55	3862,1	10,5705	62,18	3862,1	10,4993	54,41	3862,1	10,4377
680	87,98	3884,6	10,6784	73,32	3884,6	10,5942	62,84	3884,6	10,5231	54,99	3884,6	10,4615
690	88,90	3907,3	10,7020	74,09	3907,2	10,6178	63,50	3907,2	10,5467	55,56	3907,2	10,4851
700	89,83	3929,9	10,7254	74,85	3929,9	10,6413	64,16	3929,9	10,5701	56,14	3929,9	10,5085
710	90,75	3952,7	10,7487	75,62	3952,7	10,6645	64,82	3952,7	10,5934	56,72	3952,7	10,5317
720	91,67	3975,5	10,7718	76,39	3975,5	10,6876	65,48	3975,5	10,6165	57,29	3975,5	10,5548
730	92,59	3998,4	10,7947	77,16	3998,4	10,7106	66,14	3998,4	10,6394	57,87	3998,4	10,5778
740	93,52	4021,4	10,8175	77,93	4021,4	10,7333	66,80	4021,4	10,6622	58,45	4021,4	10,6004
750	94,44	4044,4	10,8401	78,70	4044,4	10,7560	67,46	4044,4	10,6848	59,03	4044,4	10,6232
760	95,36	4067,5	10,8626	79,47	4067,5	10,7784	68,12	4067,5	10,7073	59,60	4067,5	10,6457
770	96,29	4090,7	10,8849	80,24	4090,7	10,8008	68,78	4090,7	10,7296	60,18	4090,7	10,6680
780	97,21	4113,9	10,9071	81,01	4113,9	10,8229	69,44	4113,9	10,7518	60,76	4113,9	10,6902
790	98,13	4137,3	10,9291	81,78	4137,2	10,8450	70,09	4137,2	10,7738	61,33	4137,2	10,7122
800	99,06	4160,6	10,9510	82,55	4160,6	10,8669	70,75	4160,6	10,7957	61,91	4160,6	10,7341
810	99,98	4184,1	10,9728	83,32	4184,1	10,8887	71,41	4184,1	10,8175	62,49	4184,1	10,7559
820	100,90	4207,7	10,9944	84,09	4207,7	10,9103	72,07	4207,7	10,8392	63,06	4207,7	10,7775
830	101,83	4231,3	11,0159	84,85	4231,3	10,9318	72,73	4231,3	10,8606	63,64	4231,3	10,7990
840	102,75	4255,0	11,0373	85,62	4254,9	10,9532	73,39	4254,9	10,8820	64,22	4254,9	10,8204
850	103,67	4278,7	11,0585	86,39	4278,7	10,9744	74,05	4278,7	10,9032	64,79	4278,7	10,8416
860	104,59	4302,5	11,0796	87,16	4302,5	10,9955	74,71	4302,5	10,9243	65,37	4302,5	10,8627
870	105,52	4326,4	11,1006	87,93	4326,4	11,0165	75,37	4326,4	10,9453	65,95	4326,4	10,8837
880	106,44	4350,3	11,1215	88,70	4350,3	11,0373	76,03	4350,3	10,9662	66,53	4350,3	10,9045
890	107,36	4374,3	11,1422	89,47	4374,3	11,0581	76,69	4374,3	10,9869	67,10	4374,3	10,9253
900	108,29	4398,4	11,1628	90,24	4398,4	11,0787	77,35	4398,4	11,0075	67,68	4398,4	10,9459
910	109,21	4422,5	11,1833	91,01	4422,5	11,0992	78,01	4422,5	11,0280	68,26	4422,5	10,9664
920	110,13	4446,8	11,2037	91,78	4446,7	11,1195	78,67	4446,7	11,0484	68,83	4446,7	10,9868
930	111,06	4471,0	11,2239	92,55	4471,0	11,1398	79,33	4471,0	11,0686	69,41	4471,0	11,0070
940	111,98	4495,4	11,2441	93,32	4495,4	11,1599	79,99	4495,4	11,0888	69,99	4495,4	11,0272
950	112,90	4519,8	11,2641	94,09	4519,8	11,1800	80,64	4519,8	11,1088	70,56	4519,8	11,0472
960	113,83	4544,3	11,2841	94,85	4544,3	11,1999	81,30	4544,2	11,1288	71,14	4544,2	11,0671
970	114,75	4568,8	11,3039	95,62	4568,8	11,2197	81,96	4568,8	11,1486	71,72	4568,8	11,0870
980	115,67	4593,4	11,3236	96,39	4593,4	11,2394	82,62	4593,4	11,1683	72,29	4593,4	11,1067
990	116,59	4618,1	11,3432	97,16	4618,1	11,2591	83,28	4618,1	11,1879	72,87	4618,1	11,1263
1000	117,52	4642,8	11,3627	97,93	4642,8	11,2786	83,94	4642,8	11,2074	73,45	4642,8	11,1458

3-jadval (davomi)

t	$p = 9 \text{ kPa}$ $t_s = 6,98$			$p = 10 \text{ kPa}$ $t_s = 17,51$			$p = 15 \text{ kPa}$ $t_s = 24,08$			$p = 20 \text{ kPa}$ $t_s = 28,96$		
	$v^* =$ 16,200	$i^* =$ 2580,3	$s^* =$ 8,1859	$v^* =$ 14,671	$i^* =$ 2583,9	$s^* =$ 8,1489	$v^* =$ 10,020	$i^* =$ 2598,3	$s^* =$ 8,0071	$v^* = 7,648$	$i^* =$ 2608,9	$s^* =$ 7,9072
	v	i	s	v	i	s	v	i	s	v	i	s
0	0,0010002	0,0	-0,0002	0,0010002	0,0	-0,0002	0,0010002	0,0	-0,0002	0,0010002	0,0	-0,0002

t	p = 9 kPa $t_s = 6,98$			p = 10 kPa $t_s = 17,51$			p = 15 kPa $t_s = 24,08$			p = 20 kPa $t_s = 28,96$		
	$v'' =$ 16,200	$i'' =$ 2580,3	$s'' =$ 8,1859	$v'' =$ 14,671	$i'' =$ 2583,9	$s'' =$ 8,1489	$v'' =$ 10,020	$i'' =$ 2598,3	$s'' =$ 8,0071	$v'' = 7,648$	$i'' =$ 2608,9	$s'' =$ 7,9072
	v	i	s	v	i	s	v	i	s	v	i	s
10	0,0010003	42,0	0,1511	0,0010003	42,0	0,1511	0,0010003	42,0	0,1511	0,0010003	42,0	0,1511
20	0,0010018	83,9	0,2965	0,0010018	83,9	0,2965	0,0010018	83,9	0,2965	0,0010018	83,9	0,2965
30	0,0010044	125,7	0,4368	0,0010044	125,8	0,4368	0,0010044	125,8	0,4368	0,0010044	125,8	0,4368
40	0,0010079	167,5	0,5724	0,0010079	167,5	0,5724	0,0010079	167,5	0,5724	0,0010079	167,6	0,5724
50	16,52	2592,3	8,2235	14,87	2592,0	8,1741	0,0010121	209,3	0,7038	0,0010121	209,3	0,7038
60	17,04	2611,4	8,2818	15,34	2611,2	8,2326	10,21	2610,0	8,0426	0,0010171	251,2	0,8312
70	17,56	2630,5	8,3382	15,80	2630,3	8,2891	10,52	2629,3	8,0997	7,88	2628,3	7,9646
80	18,08	2649,5	8,3928	16,27	2649,3	8,3438	10,83	2648,5	8,1548	8,12	2647,7	8,0202
90	18,59	2668,5	8,4460	16,73	2668,4	8,3970	11,15	2667,7	8,2083	8,35	2667,0	8,0740
100	19,11	2687,6	8,4977	17,20	2687,4	8,4488	11,46	2686,8	8,2603	8,59	2686,2	8,1262
110	19,63	2706,6	8,5480	17,66	2706,5	8,4992	11,77	2706,0	8,3109	8,82	2705,4	8,1770
120	20,14	2725,7	8,5972	18,12	2725,6	8,5484	12,08	2725,1	8,3603	9,05	2724,6	8,2265
130	20,65	2744,8	8,6452	18,59	2744,7	8,5964	12,39	2744,3	8,4084	9,28	2743,8	8,2748
140	21,17	2763,9	8,6920	19,05	2763,8	8,6433	12,69	2763,5	8,4554	9,52	2763,1	8,3219
150	21,68	2783,1	8,7379	19,51	2783,0	8,6892	13,00	2782,7	8,5014	9,75	2782,3	8,3680
160	22,20	2802,3	8,7828	19,98	2802,2	8,7340	13,31	2801,9	8,5464	9,98	2801,6	8,4130
170	22,71	2821,6	8,8267	20,44	2821,5	8,7780	13,62	2821,2	8,5904	10,21	2820,9	8,4571
180	23,23	2840,9	8,8698	20,90	2840,8	8,8211	13,93	2840,6	8,6335	10,44	2840,3	8,5003
190	23,74	2860,2	8,9121	21,36	2860,2	8,8634	14,24	2859,9	8,6758	10,68	2859,7	8,5427
200	24,25	2879,6	8,9535	21,83	2879,6	8,9048	14,55	2879,4	8,7173	10,91	2879,1	8,5842
210	24,77	2899,1	8,9942	22,29	2899,1	8,9455	14,86	2898,8	8,7581	11,14	2898,6	8,6250
220	25,28	2918,6	9,0342	22,75	2918,6	8,9855	15,16	2918,4	8,7981	11,37	2918,2	8,6650
230	25,79	2938,2	9,0735	23,21	2938,1	9,0248	15,47	2938,0	8,8374	11,60	2937,8	8,7044
240	26,31	2957,8	9,1121	23,67	2957,8	9,0634	15,78	2957,6	8,8760	11,83	2957,4	8,7430
250	26,82	2977,5	9,1501	24,14	2977,4	9,1014	16,09	2977,3	8,9141	12,06	2977,1	8,7811
260	27,33	2997,2	9,1875	24,60	2997,2	9,1388	16,40	2997,0	8,9515	12,30	2996,9	8,8185
270	27,85	3017,0	9,2242	25,06	3017,0	9,1756	16,70	3016,8	8,9883	12,53	3016,7	8,8553
280	28,36	3036,9	9,2605	25,52	3036,8	9,2118	17,01	3036,7	9,0245	12,76	3036,6	8,8915
290	28,87	3056,8	9,2962	25,98	3056,8	9,2475	17,32	3056,6	9,0602	12,99	3056,5	8,9273
300	29,39	3076,8	9,3313	26,45	3076,7	9,2827	17,63	3076,6	9,0954	13,22	3076,5	8,9624
310	29,90	3096,8	9,3660	26,91	3096,8	9,3173	17,94	3096,7	9,1300	13,45	3096,5	8,9971
320	30,41	3116,9	9,4001	27,37	3116,9	9,3515	18,24	3116,8	9,1642	13,68	3116,7	9,0313
330	30,92	3137,1	9,4338	27,83	3137,0	9,3852	18,55	3136,9	9,1979	13,91	3136,8	9,0650
340	31,44	3157,3	9,4671	28,29	3157,3	9,4185	18,86	3157,2	9,2312	14,14	3157,1	9,0983
350	31,95	3177,6	9,4999	28,75	3177,5	9,4513	19,17	3177,4	9,2640	14,37	3177,4	9,1311
360	32,46	3197,9	9,5323	29,22	3197,9	9,4837	19,48	3197,8	9,2964	14,61	3197,7	9,1635
370	32,98	3218,3	9,5643	29,68	3218,3	9,5157	19,78	3218,2	9,3284	14,84	3218,1	9,1956
380	33,49	3238,8	9,5959	30,14	3238,8	9,5473	20,09	3238,7	9,3600	15,07	3238,6	9,2272
390	34,00	3259,3	9,6271	30,60	3259,3	9,5785	20,40	3259,2	9,3912	15,30	3259,2	9,2584
400	34,52	3280,0	9,6580	31,06	3279,9	9,6093	20,71	3279,9	9,4221	15,53	3279,8	9,2892
410	35,03	3300,6	9,6884	31,53	3300,6	9,6398	21,02	3300,5	9,4526	15,76	3300,5	9,3197
420	35,54	3321,4	9,7186	31,99	3321,3	9,6699	21,32	3321,3	9,4827	15,99	3321,2	9,3499
430	36,05	3342,2	9,7484	32,45	3342,2	9,6997	21,63	3342,1	9,5125	16,22	3342,0	9,3797

t	p = 9 kPa t _s = 6,98			p = 10 kPa t _s = 17,51			p = 15 kPa t _s = 24,08			p = 20 kPa t _s = 28,96		
	v [*] = 16,200	i [*] = 2580,3	s [*] = 8,1859	v [*] = 14,671	i [*] = 2583,9	s [*] = 8,1489	v [*] = 10,020	i [*] = 2598,3	s [*] = 8,0071	v [*] = 7,648	i [*] = 2608,9	s [*] = 7,9072
	v	i	s	v	i	s	v	i	s	v	i	s
440	36,57	3363,0	9,7778	32,91	3363,0	9,7292	21,94	3363,0	9,5420	16,45	3362,9	9,4092
450	37,08	3384,0	9,8070	33,37	3384,0	9,7584	22,25	3383,9	9,5712	16,68	3383,8	9,4383
460	37,59	3405,0	9,8359	33,83	3405,0	9,7872	22,55	3404,9	9,6000	16,92	3404,8	9,4672
470	38,11	3426,1	9,8644	34,30	3426,0	9,8158	22,86	3426,0	9,6286	17,15	3425,9	9,4957
480	38,62	3447,2	9,8927	34,76	3447,2	9,8440	23,17	3447,1	9,6568	17,38	3447,1	9,5240
490	39,13	3468,4	9,9206	35,22	3468,4	9,8720	23,48	3468,3	9,6848	17,61	3468,3	9,5520
500	39,64	3489,7	9,9483	35,68	3489,7	9,8997	23,79	3489,6	9,7125	17,84	3489,6	9,5797
510	40,16	3511,0	9,9758	36,14	3511,0	9,9271	24,09	3511,0	9,7400	18,07	3510,9	9,6071
520	40,67	3532,4	10,0029	36,60	3532,4	9,9543	24,40	3532,4	9,7671	18,30	3532,3	9,6343
530	41,18	3553,9	10,0299	37,07	3553,9	9,9812	24,71	3553,9	9,7940	18,53	3553,8	9,6612
540	41,70	3575,5	10,0565	37,53	3575,5	10,0079	25,02	3575,4	9,8207	18,76	3575,4	9,6879
550	42,21	3597,1	10,0830	37,99	3597,1	10,0343	25,32	3597,1	9,8472	18,99	3597,0	9,7143
560	42,72	3618,8	10,1092	38,45	3618,8	10,0605	25,63	3618,7	9,8733	19,22	3618,7	9,7405
570	43,24	3640,6	10,1351	38,91	3640,6	10,0865	25,94	3640,5	9,8993	19,45	3640,5	9,7665
580	43,75	3662,4	10,1609	39,37	3662,4	10,1122	26,25	3662,4	9,9251	19,69	3662,3	9,7923
590	44,26	3684,3	10,1864	39,83	3684,3	10,1378	26,56	3684,3	9,9506	19,92	3684,2	9,8178
600	44,77	3706,3	10,2117	40,30	3706,3	10,1631	26,86	3706,2	9,9759	20,15	3706,2	9,8431
610	45,29	3728,3	10,2368	40,76	3728,3	10,1882	27,17	3728,3	10,0010	20,38	3728,2	9,8682
620	45,80	3750,4	10,2617	41,22	3750,4	10,2131	27,48	3750,4	10,0259	20,61	3750,4	9,8931
630	46,31	3772,6	10,2864	41,68	3772,6	10,2378	27,79	3772,6	10,0506	20,84	3772,5	9,9178
640	46,83	3794,9	10,3109	42,14	3794,9	10,2623	28,09	3794,8	10,0751	21,07	3794,8	9,9423
650	47,34	3817,2	10,3352	42,60	3817,2	10,2866	28,40	3817,2	10,0994	21,30	3817,1	9,9666
660	47,85	3839,6	10,3594	43,07	3839,6	10,3107	28,71	3839,6	10,1236	21,53	3839,5	9,9908
670	48,36	3862,1	10,3833	43,53	3862,1	10,3347	29,02	3862,0	10,1475	21,76	3862,0	10,0147
680	48,88	3884,6	10,4071	43,99	3884,6	10,3585	29,33	3884,6	10,1713	21,99	3884,6	10,0385
690	49,39	3907,2	10,4307	44,45	3907,2	10,3821	29,63	3907,2	10,1949	22,22	3907,2	10,0621
700	49,90	3929,9	10,4541	44,91	3929,9	10,4055	29,94	3929,9	10,2183	22,46	3929,8	10,0855
710	50,42	3952,7	10,4774	45,37	3952,7	10,4288	30,25	3952,6	10,2416	22,69	3952,6	10,1088
720	50,93	3975,5	10,5005	45,84	3975,5	10,4519	30,56	3975,5	10,2647	22,92	3975,4	10,1319
730	51,44	3998,4	10,5234	46,30	3998,4	10,4748	30,86	3998,4	10,2876	23,15	3998,3	10,1548
740	51,95	4021,3	10,5462	46,76	4021,3	10,4976	31,17	4021,3	10,3104	23,38	4021,3	10,1776
750	52,47	4044,4	10,5688	47,22	4044,4	10,5202	31,48	4044,4	10,3330	23,61	4044,3	10,2002
760	52,98	4067,5	10,5913	47,68	4067,5	10,5427	31,79	4067,5	10,3555	23,84	4067,4	10,2227
770	53,49	4090,7	10,6136	48,14	4090,7	10,5650	32,10	4090,6	10,3778	24,07	4090,6	10,2451
780	54,01	4113,9	10,6358	48,60	4113,9	10,5872	32,40	4113,9	10,4000	24,30	4113,9	10,2672
790	54,52	4137,2	10,6578	49,07	4137,2	10,6092	32,71	4137,2	10,4221	24,53	4137,2	10,2893
800	55,03	4160,6	10,6797	49,53	4160,6	10,6311	33,02	4160,6	10,4440	24,76	4160,6	10,3112
810	55,54	4184,1	10,7015	49,99	4184,1	10,6529	33,33	4184,1	10,4657	24,99	4184,1	10,3330
820	56,06	4207,7	10,7232	50,45	4207,6	10,6745	33,63	4207,6	10,4874	25,23	4207,6	10,3546
830	56,57	4231,3	10,7447	50,91	4231,3	10,6960	33,94	4231,2	10,5089	25,46	4231,2	10,3761
840	57,08	4254,9	10,7660	51,37	4254,9	10,7174	34,25	4254,9	10,5302	25,69	4254,9	10,3975
850	57,60	4278,7	10,7872	51,84	4278,7	10,7386	34,56	4278,7	10,5515	25,92	4278,6	10,4187
860	58,11	4302,5	10,8084	52,30	4302,5	10,7597	34,86	4302,5	10,5726	26,15	4302,4	10,4398

t	p = 9 κfla t _p = 6,98			p = 10 κfla t _p = 17,51			p = 15 κfla t _p = 24,08			p = 20 κfla t _p = 28,96		
	v ⁻ = 16,200	i ⁻ = 2580,3	s ⁻ = 8,1859	v ⁻ = 14,671	i ⁻ = 2583,9	s ⁻ = 8,1489	v ⁻ = 10,020	i ⁻ = 2598,3	s ⁻ = 8,0071	v ⁻ = 7,648	i ⁻ = 2608,9	s ⁻ = 7,9072
	v	i	s	v	i	s	v	i	s	v	i	s
870	58,62	4326,4	10,8293	52,76	4326,4	10,7807	35,17	4326,3	10,5936	26,38	4326,3	10,4608
880	59,13	4350,3	10,8502	53,22	4350,3	10,8016	35,48	4350,3	10,6144	26,61	4350,3	10,4816
890	59,65	4374,3	10,8709	53,68	4374,3	10,8223	35,79	4374,3	10,6351	26,84	4374,3	10,5024
900	60,16	4398,4	10,8915	54,14	4398,4	10,8429	36,10	4398,4	10,6557	27,07	4398,3	10,5230
910	60,67	4422,5	10,9120	54,60	4422,5	10,8634	36,40	4422,5	10,6762	27,30	4422,5	10,5435
920	61,18	4446,7	10,9324	55,07	4446,7	10,8838	36,71	4446,7	10,6966	27,53	4446,7	10,5638
930	61,70	4471,0	10,9527	55,53	4471,0	10,9040	37,02	4471,0	10,7169	27,76	4471,0	10,5841
940	62,21	4495,4	10,9728	55,99	4495,4	10,9242	37,33	4495,3	10,7370	27,99	4495,3	10,6042
950	62,72	4519,8	10,9928	56,45	4519,8	10,9442	37,63	4519,7	10,7571	28,23	4519,7	10,6243
960	63,24	4544,2	11,0128	56,91	4544,2	10,9641	37,94	4544,2	10,7770	28,46	4544,2	10,6442
970	63,75	4568,8	11,0326	57,37	4568,8	10,9840	38,25	4568,8	10,7968	28,69	4568,8	10,6640
980	64,26	4593,4	11,0523	57,84	4593,4	11,0037	38,56	4593,4	10,8165	28,92	4593,4	10,6838
990	64,77	4618,1	11,0719	58,30	4618,1	11,0233	38,86	4618,0	10,8361	29,15	4618,0	10,7034
1000	65,29	4642,8	11,0914	58,76	4642,8	11,0428	39,17	4642,8	10,8557	29,38	4642,8	10,7229

3-Jadval (davomi)

t	p = 25 κfla t _p = 64,96			p = 30 κfla t _p = 69,10			p = 35 κfla t _p = 72,68			p = 40 κfla t _p = 75,86		
	v ⁻ = 6,203	i ⁻ = 2617,4	s ⁻ = 7,8302	v ⁻ = 5,229	i ⁻ = 2624,7	s ⁻ = 7,7675	v ⁻ = 4,525	i ⁻ = 2630,7	s ⁻ = 7,7146	v ⁻ = 3,993	i ⁻ = 2636,1	s ⁻ = 7,6690
	v	i	s	v	i	s	v	i	s	v	i	s
0	0,0010002	0,0	-0,0002	0,0010002	0,0	-0,0002	0,0010002	0,0	-0,0002	0,0010002	0,0	-0,0002
10	0,0010003	42,0	0,1511	0,0010003	42,0	0,1511	0,0010003	42,1	0,1511	0,0010003	42,1	0,1511
20	0,0010018	83,9	0,2965	0,0010018	83,9	0,2965	0,0010018	84,0	0,2965	0,0010018	84,0	0,2965
30	0,0010044	125,8	0,4368	0,0010044	125,8	0,4368	0,0010044	125,8	0,4368	0,0010044	125,8	0,4368
40	0,0010079	167,6	0,5724	0,0010079	167,6	0,5724	0,0010079	167,6	0,5724	0,0010079	167,6	0,5724
50	0,0010121	209,3	0,7038	0,0010121	209,4	0,7038	0,0010121	209,4	0,7038	0,0010121	209,4	0,7038
60	0,0010171	251,2	0,8312	0,0010171	251,2	0,8312	0,0010171	251,2	0,8312	0,0010171	251,2	0,8312
70	6,299	2627,4	7,8593	5,243	2626,3	7,7727	0,0010228	293,0	0,9550	0,0010228	293,0	0,9550
80	6,488	2646,9	7,9153	5,401	2646,0	7,8292	4,625	2645,2	7,7561	4,04	2644,3	7,6925
90	6,676	2666,2	7,9694	5,558	2665,5	7,8837	4,760	2664,8	7,8109	4,16	2664,1	7,7477
100	6,863	2685,6	8,0219	5,715	2684,9	7,9364	4,895	2684,3	7,8639	4,28	2683,7	7,8009
110	7,051	2704,9	8,0729	5,872	2704,3	7,9876	5,029	2703,8	7,9153	4,40	2703,2	7,8525
120	7,237	2724,1	8,1226	6,028	2723,6	8,0374	5,163	2723,1	7,9653	4,52	2722,7	7,9027
130	7,424	2743,4	8,1710	6,183	2743,0	8,0860	5,297	2742,5	8,0140	4,63	2742,1	7,9515
140	7,610	2762,7	8,2182	6,339	2762,5	8,1333	5,431	2761,9	8,0614	4,75	2761,5	7,9991
150	7,796	2782,0	8,2643	6,494	2781,6	8,1796	5,564	2781,3	8,1078	4,87	2780,9	8,0455
160	7,982	2801,3	8,3095	6,649	2801,0	8,2248	5,697	2800,6	8,1530	4,98	2800,3	8,0908
170	8,167	2820,6	8,3536	6,804	2820,3	8,2690	5,830	2820,1	8,1973	5,10	2819,8	8,1352
180	8,353	2840,0	8,3969	6,959	2839,8	8,3123	5,963	2839,5	8,2407	5,22	2839,2	8,1786
190	8,538	2859,4	8,4393	7,113	2859,2	8,3547	6,095	2859,0	8,2832	5,33	2858,7	8,2212
200	8,724	2878,9	8,4809	7,268	2878,7	8,3964	6,228	2878,5	8,3248	5,45	2878,2	8,2629
210	8,909	2898,4	8,5217	7,422	2898,2	8,4372	6,361	2898,0	8,3657	5,56	2897,8	8,3038

t	$\rho = 25 \text{ k}\Gamma\text{la}$ $t_c = 64,96$			$\rho = 30 \text{ k}\Gamma\text{la}$ $t_c = 69,10$			$\rho = 35 \text{ k}\Gamma\text{la}$ $t_c = 72,68$			$\rho = 40 \text{ k}\Gamma\text{la}$ $t_c = 75,86$		
	$v' = 6,203$	$i' = 2617,4$	$s' = 7,8302$	$v' = 5,229$	$i' = 2624,7$	$s' = 7,7675$	$v' = 4,525$	$i' = 2630,7$	$s' = 7,7146$	$v' = 3,993$	$i' = 2636,1$	$s' = 7,6690$
	v	i	s	v	i	s	v	i	s	v	i	s
220	9,094	2918,0	8,5617	7,577	2917,8	8,4773	6,493	2917,6	8,4059	5,68	2917,4	8,3439
230	9,279	2937,6	8,6011	7,731	2937,4	8,5167	6,626	2937,2	8,4453	5,80	2937,0	8,3834
240	9,465	2957,3	8,6398	7,886	2957,1	8,5554	6,758	2956,9	8,4840	5,91	2956,7	8,4221
250	9,650	2977,0	8,6778	8,040	2976,8	8,5935	6,890	2976,6	8,5227	6,03	2976,5	8,4602
260	9,835	2996,7	8,7153	8,194	2996,6	8,6309	7,023	2996,4	8,5596	6,14	2996,3	8,4977
270	10,020	3016,6	8,7521	8,349	3016,4	8,6678	7,155	3016,3	8,5964	6,26	3016,1	8,5346
280	10,205	3036,4	8,7884	8,503	3036,3	8,7040	7,287	3036,2	8,6327	6,38	3036,0	8,5709
290	10,390	3056,4	8,8241	8,657	3056,2	8,7398	7,419	3056,1	8,6685	6,49	3056,0	8,6067
300	10,575	3076,4	8,8593	8,811	3076,2	8,7750	7,551	3076,1	8,7037	6,61	3076,0	8,6419
310	10,760	3096,4	8,8940	8,965	3096,3	8,8097	7,684	3096,2	8,7384	6,72	3096,1	8,6766
320	10,944	3116,5	8,9282	9,119	3116,4	8,8439	7,816	3116,3	8,7726	6,84	3116,2	8,7109
330	11,129	3136,7	8,9619	9,273	3136,6	8,8776	7,948	3136,5	8,8064	6,95	3136,4	8,7446
340	11,314	3157,0	8,9952	9,428	3156,9	8,9109	8,080	3156,8	8,8397	7,07	3156,7	8,7779
350	11,499	3177,3	9,0280	9,582	3177,2	8,9438	8,212	3177,1	8,8725	7,18	3177,0	8,8108
360	11,684	3197,6	9,0605	9,736	3197,5	8,9762	8,344	3197,4	8,9050	7,30	3197,3	8,8432
370	11,869	3218,0	9,0925	9,890	3218,0	9,0082	8,476	3217,9	8,9370	7,42	3217,8	8,8752
380	12,053	3238,5	9,1241	10,044	3238,4	9,0398	8,608	3238,4	8,9686	7,53	3238,3	8,9069
390	12,238	3259,1	9,1553	10,198	3259,0	9,0711	8,740	3258,9	8,9998	7,65	3258,8	8,9381
400	12,423	3279,7	9,1862	10,352	3279,6	9,1019	8,872	3279,5	9,0307	7,76	3279,5	8,9690
410	12,608	3300,4	9,2167	10,506	3300,3	9,1324	9,004	3300,2	9,0612	7,88	3300,2	8,9995
420	12,793	3321,1	9,2468	10,660	3321,1	9,1626	9,136	3321,0	9,0914	7,99	3320,9	9,0297
430	12,977	3341,9	9,2766	10,814	3341,9	9,1924	9,268	3341,8	9,1212	8,11	3341,7	9,0595
440	13,162	3362,8	9,3061	10,968	3362,8	9,2219	9,400	3362,7	9,1507	8,23	3362,6	9,0890
450	13,347	3383,8	9,3353	11,122	3383,7	9,2511	9,532	3383,6	9,1799	8,34	3383,6	9,1182
460	13,532	3404,8	9,3641	11,276	3404,7	9,2799	9,664	3404,7	9,2087	8,46	3404,6	9,1470
470	13,716	3425,9	9,3927	11,430	3425,8	9,3085	9,796	3425,7	9,2373	8,57	3425,7	9,1756
480	13,901	3447,0	9,4210	11,584	3447,0	9,3368	9,928	3446,9	9,2656	8,69	3446,8	9,2039
490	14,086	3468,2	9,4489	11,738	3468,2	9,3647	10,060	3468,1	9,2935	8,80	3468,1	9,2319
500	14,270	3489,5	9,4767	11,892	3489,5	9,3925	10,192	3489,4	9,3213	8,92	3489,4	9,2596
510	14,455	3510,9	9,5041	12,046	3510,8	9,4199	10,324	3510,8	9,3487	9,03	3510,7	9,2870
520	14,640	3532,3	9,5313	12,199	3532,2	9,4471	10,456	3532,2	9,3759	9,15	3532,1	9,3142
530	14,825	3553,8	9,5582	12,353	3553,7	9,4740	10,588	3553,7	9,4028	9,26	3553,6	9,3411
540	15,009	3575,3	9,5849	12,507	3575,3	9,5007	10,720	3575,2	9,4295	9,38	3575,2	9,3678
550	15,194	3597,0	9,6113	12,661	3596,9	9,5271	10,852	3596,9	9,4559	9,50	3596,8	9,3943
560	15,379	3618,7	9,6375	12,815	3618,6	9,5533	10,984	3618,6	9,4821	9,61	3618,5	9,4205
570	15,563	3640,4	9,6635	12,969	3640,4	9,5793	11,116	3640,3	9,5081	9,73	3640,3	9,4464
580	15,748	3662,3	9,6892	13,123	3662,2	9,6050	11,248	3662,2	9,5339	9,84	3662,1	9,4722
590	15,933	3684,2	9,7148	13,277	3684,1	9,6306	11,380	3684,1	9,5594	9,96	3684,1	9,4977
600	16,117	3706,2	9,7401	13,431	3706,1	9,6559	11,512	3706,1	9,5847	10,07	3706,0	9,5231
610	16,302	3728,2	9,7652	13,585	3728,2	9,6810	11,644	3728,1	9,6098	10,19	3728,1	9,5482
620	16,487	3750,3	9,7901	13,739	3750,3	9,7059	11,776	3750,2	9,6347	10,30	3750,2	9,5731
630	16,671	3772,5	9,8148	13,893	3772,5	9,7306	11,908	3772,4	9,6594	10,42	3772,4	9,5978
640	16,856	3794,8	9,8393	14,046	3794,7	9,7551	12,040	3794,7	9,6840	10,53	3794,7	9,6223

t	p = 25 kPa t _s = 64,96			p = 30 kPa t _s = 69,10			p = 35 kPa t _s = 72,68			p = 40 kPa t _s = 75,86		
	v ⁻ = 6,203	i ⁻ = 2617,4	s ⁻ = 7,8302	v ⁻ = 5,229	i ⁻ = 2624,7	s ⁻ = 7,7675	v ⁻ = 4,525	i ⁻ = 2630,7	s ⁻ = 7,7146	v ⁻ = 3,993	i ⁻ = 2636,1	s ⁻ = 7,6690
	v	i	s	v	i	s	v	i	s	v	i	s
650	17,041	3817,1	9,8636	14,200	3817,1	9,7795	12,172	3817,0	9,7083	10,65	3817,0	9,6466
660	17,225	3839,5	9,8878	14,354	3839,5	9,8036	12,303	3839,4	9,7324	10,77	3839,4	9,6708
670	17,410	3862,0	9,9117	14,508	3861,9	9,8275	12,435	3861,9	9,7564	10,88	3861,9	9,6947
680	17,595	3884,5	9,9355	14,662	3884,5	9,8513	12,567	3884,5	9,7802	11,00	3884,4	9,7185
690	17,779	3907,1	9,9591	14,816	3907,1	9,8749	12,699	3907,1	9,8038	11,11	3907,0	9,7421
700	17,964	3929,8	9,9825	14,970	3929,8	9,8984	12,831	3929,8	9,8272	11,23	3929,7	9,7655
710	18,149	3952,6	10,0058	15,124	3952,5	9,9216	12,963	3952,5	9,8505	11,34	3952,5	9,7888
720	18,333	3975,4	10,0289	15,278	3975,4	9,9447	13,095	3975,3	9,8736	11,46	3975,3	9,8119
730	18,518	3998,3	10,0518	15,431	3998,3	9,9677	13,227	3998,2	9,8965	11,57	3998,2	9,8349
740	18,703	4021,3	10,0746	15,585	4021,2	9,9904	13,359	4021,2	9,9193	11,69	4021,2	9,8576
750	18,887	4044,3	10,0972	15,739	4044,3	10,0131	13,491	4044,3	9,9419	11,80	4044,2	9,8803
760	19,072	4067,4	10,1197	15,893	4067,4	10,0356	13,623	4067,4	9,9644	11,92	4067,3	9,9027
770	19,257	4090,6	10,1420	16,047	4090,6	10,0579	13,754	4090,5	9,9867	12,04	4090,5	9,9251
780	19,441	4113,8	10,1642	16,201	4113,8	10,0801	13,886	4113,8	10,0089	12,15	4113,8	9,9473
790	19,626	4137,2	10,1863	16,355	4137,1	10,1021	14,018	4137,1	10,0309	12,27	4137,1	9,9693
800	19,811	4160,6	10,2082	16,509	4160,5	10,1240	14,150	4160,5	10,0528	12,38	4160,5	9,9912
810	19,995	4184,0	10,2300	16,663	4184,0	10,1458	14,282	4184,0	10,0746	12,50	4184,0	10,0130
820	20,180	4207,6	10,2516	16,816	4207,6	10,1674	14,414	4207,5	10,0963	12,61	4207,5	10,0346
830	20,364	4231,2	10,2731	16,970	4231,2	10,1889	14,546	4231,2	10,1178	12,73	4231,1	10,0561
840	20,549	4254,9	10,2944	17,124	4254,8	10,2103	14,678	4254,8	10,1391	12,84	4254,8	10,0775
850	20,734	4278,6	10,3157	17,278	4278,6	10,2315	14,810	4278,6	10,1604	12,96	4278,6	10,0987
860	20,918	4302,4	10,3368	17,432	4302,4	10,2526	14,942	4302,4	10,1815	13,07	4302,4	10,1198
870	21,103	4326,3	10,3578	17,586	4326,3	10,2736	15,073	4326,3	10,2024	13,19	4326,2	10,1408
880	21,288	4350,2	10,3786	17,740	4350,2	10,2945	15,205	4350,2	10,2233	13,30	4350,2	10,1617
890	21,472	4374,3	10,3994	17,894	4374,2	10,3152	15,337	4374,2	10,2440	13,42	4374,2	10,1824
900	21,657	4398,3	10,4200	18,047	4398,3	10,3358	15,469	4398,3	10,2646	13,54	4398,3	10,2030
910	21,842	4422,5	10,4405	18,201	4422,5	10,3563	15,601	4422,4	10,2851	13,65	4422,4	10,2235
920	22,026	4446,7	10,4608	18,355	4446,7	10,3767	15,733	4446,6	10,3055	13,77	4446,6	10,2439
930	22,211	4471,0	10,4811	18,509	4470,9	10,3969	15,865	4470,9	10,3258	13,88	4470,9	10,2641
940	22,396	4495,3	10,5012	18,663	4495,3	10,4171	15,997	4495,3	10,3459	14,00	4495,3	10,2843
950	22,580	4519,7	10,5213	18,817	4519,7	10,4371	16,129	4519,7	10,3660	14,11	4519,7	10,3043
960	22,765	4544,2	10,5412	18,971	4544,2	10,4571	16,260	4544,2	10,3859	14,23	4544,1	10,3243
970	22,949	4568,7	10,5610	19,124	4568,7	10,4769	16,392	4568,7	10,4057	14,34	4568,7	10,3441
980	23,134	4593,3	10,5808	19,278	4593,3	10,4966	16,524	4593,3	10,4254	14,46	4593,3	10,3638
990	23,319	4618,0	10,6004	19,432	4618,0	10,5162	16,656	4618,0	10,4451	14,57	4618,0	10,3834
1000	23,503	4642,8	10,6199	19,586	4642,7	10,5357	16,788	4642,7	10,4646	14,69	4642,7	10,4029

3-jadval (davomi)

t	p = 45 κfLa t _g = 78,71			p = 50 κfLa t _g = 81,32			p = 60 κfLa t _g = 85,93			p = 70 κfLa t _g = 89,93		
	v' = 3,576	i' = 2640,9	s' = 7,6288	v' = 3,240	i' = 2645,2	s' = 7,5930	v' = 2,732	i' = 2652,9	s' = 7,5311	v' = 2,365	i' = 2659,4	s' = 7,4790
	v	i	s	v	i	s	v	i	s	v	i	s
0	0,0010002	0,0	-0,0002	0,0010002	0,0	-0,0002	0,0010002	0,0	-0,0002	0,0010002	0,0	-0,0001
10	0,0010003	42,1	0,1511	0,0010003	42,1	0,1511	0,0010003	42,1	0,1511	0,0010003	42,1	0,1511
20	0,0010018	84,0	0,2965	0,0010018	84,0	0,2965	0,0010018	84,0	0,2965	0,0010018	84,0	0,2965
30	0,0010044	125,8	0,4368	0,0010044	125,8	0,4368	0,0010044	125,8	0,4368	0,0010044	125,8	0,4368
40	0,0010079	167,6	0,5724	0,0010079	167,6	0,5724	0,0010079	167,6	0,5724	0,0010079	167,6	0,5724
50	0,0010121	209,4	0,7038	0,0010121	209,4	0,7038	0,0010121	209,4	0,7038	0,0010121	209,4	0,7038
60	0,0010171	251,2	0,8312	0,0010171	251,2	0,8312	0,0010171	251,2	0,8312	0,0010171	251,2	0,8312
70	0,0010228	293,0	0,9550	0,0010227	293,0	0,9550	0,0010227	293,0	0,9550	0,0010227	293,0	0,9550
80	3,590	2643,4	7,6361	0,0010290	335,0	1,0754	0,0010290	335,0	1,0754	0,0010290	335,0	1,0754
90	3,696	2663,3	7,6917	3,323	2662,6	7,6414	2,765	2661,1	7,5539	2,365	2659,6	7,4793
100	3,802	2683,0	7,7452	3,419	2682,4	7,6952	2,845	2681,1	7,6083	2,434	2679,8	7,5343
110	3,907	2702,6	7,7970	3,514	2702,1	7,7472	2,924	2700,9	7,6608	2,503	2699,8	7,5872
120	4,011	2722,2	7,8473	3,608	2721,7	7,7977	3,003	2720,7	7,7116	2,571	2719,7	7,6384
130	4,116	2741,6	7,8963	3,702	2741,2	7,8468	3,082	2740,3	7,7609	2,639	2739,4	7,6880
140	4,220	2761,1	7,9440	3,796	2760,7	7,8946	3,161	2759,9	7,8089	2,706	2759,1	7,7363
150	4,324	2780,6	7,9905	3,890	2780,2	7,9412	3,239	2779,5	7,8557	2,774	2778,8	7,7833
160	4,428	2800,0	8,0359	3,983	2799,7	7,9867	3,317	2799,0	7,9014	2,841	2798,4	7,8291
170	4,531	2819,5	8,0803	4,077	2819,2	8,0312	3,395	2818,6	7,9460	2,908	2818,0	7,8739
180	4,635	2839,0	8,1238	4,170	2838,7	8,0747	3,473	2838,1	7,9897	2,975	2837,6	7,9176
190	4,738	2858,5	8,1664	4,263	2858,2	8,1174	3,551	2857,7	8,0324	3,042	2857,2	7,9604
200	4,842	2878,0	8,2081	4,356	2877,8	8,1591	3,628	2877,3	8,0743	3,108	2876,9	8,0024
210	4,945	2897,6	8,2491	4,449	2897,4	8,2001	3,706	2896,9	8,1153	3,175	2896,5	8,0435
220	5,048	2917,2	8,2893	4,542	2917,0	8,2403	3,784	2916,6	8,1556	3,242	2916,2	8,0838
230	5,151	2936,9	8,3287	4,635	2936,7	8,2798	3,861	2936,3	8,1951	3,308	2935,9	8,1234
240	5,254	2956,6	8,3675	4,728	2956,4	8,3186	3,938	2956,0	8,2340	3,375	2955,7	8,1623
250	5,357	2976,3	8,4056	4,821	2976,2	8,3568	4,016	2975,8	8,2722	3,441	2975,5	8,2006
260	5,460	2996,1	8,4431	4,913	2996,0	8,3943	4,093	2995,7	8,3097	3,507	2995,4	8,2382
270	5,563	3016,0	8,4800	5,006	3015,8	8,4312	4,171	3015,6	8,3467	3,574	3015,3	8,2751
280	5,666	3035,9	8,5164	5,099	3035,8	8,4676	4,248	3035,5	8,3831	3,640	3035,2	8,3115
290	5,769	3055,9	8,5521	5,191	3055,7	8,5034	4,325	3055,5	8,4189	3,706	3055,2	8,3474
300	5,872	3075,9	8,5874	5,284	3075,8	8,5386	4,402	3075,5	8,4541	3,773	3075,3	8,3827
310	5,975	3096,0	8,6221	5,377	3095,8	8,5733	4,480	3095,6	8,4889	3,839	3095,4	8,4175
320	6,078	3116,1	8,6564	5,469	3116,0	8,6076	4,557	3115,8	8,5232	3,905	3115,5	8,4518
330	6,180	3136,3	8,6901	5,562	3136,2	8,6414	4,634	3136,0	8,5570	3,971	3135,8	8,4856
340	6,283	3156,6	8,7234	5,654	3156,5	8,6747	4,711	3156,3	8,5903	4,037	3156,1	8,5189
350	6,386	3176,9	8,7563	5,747	3176,8	8,7076	4,788	3176,6	8,6232	4,104	3176,4	8,5518
360	6,489	3197,3	8,7888	5,840	3197,2	8,7400	4,865	3197,0	8,6557	4,170	3196,8	8,5843
370	6,592	3217,7	8,8208	5,932	3217,6	8,7721	4,943	3217,4	8,6877	4,236	3217,3	8,6164
380	6,694	3238,2	8,8524	6,025	3238,1	8,8037	5,020	3237,9	8,7194	4,302	3237,8	8,6480
390	6,797	3258,8	8,8837	6,117	3258,7	8,8349	5,097	3258,5	8,7506	4,368	3258,4	8,6793
400	6,900	3279,4	8,9145	6,209	3279,3	8,8658	5,174	3279,2	8,7815	4,434	3279,0	8,7102

t	p = 45 кПа t _с = 78,71			p = 50 кПа t _с = 81,32			p = 60 кПа t _с = 85,93			p = 70 кПа t _с = 89,93		
	v [*] = 3,576	i [*] = 2640,9	s [*] = 7,6288	v [*] = 3,240	i [*] = 2645,2	s [*] = 7,5930	v [*] = 2,732	i [*] = 2652,9	s [*] = 7,5311	v [*] = 2,365	i [*] = 2659,4	s [*] = 7,4790
	v	i	s	v	i	s	v	i	s	v	i	s
0	0,0010002	0,0	-0,0002	0,0010002	0,0	-0,0002	0,0010002	0,0	-0,0002	0,0010002	0,0	-0,0001
10	0,0010003	42,1	0,1511	0,0010003	42,1	0,1511	0,0010003	42,1	0,1511	0,0010003	42,1	0,1511
20	0,0010018	84,0	0,2965	0,0010018	84,0	0,2965	0,0010018	84,0	0,2965	0,0010018	84,0	0,2965
30	0,0010044	125,8	0,4368	0,0010044	125,8	0,4368	0,0010044	125,8	0,4368	0,0010044	125,8	0,4368
410	7,003	3300,1	8,9451	6,302	3300,0	8,8964	5,251	3299,9	8,8120	4,500	3299,7	8,7407
420	7,105	3320,8	8,9752	6,394	3320,8	8,9265	5,328	3320,6	8,8422	4,566	3320,5	8,7709
430	7,208	3341,7	9,0051	6,487	3341,6	8,9564	5,405	3341,5	8,8721	4,632	3341,3	8,8008
440	7,311	3362,6	9,0346	6,579	3362,5	8,9859	5,482	3362,4	8,9016	4,699	3362,2	8,8303
450	7,413	3383,5	9,0637	6,672	3383,5	9,0150	5,559	3383,3	8,9308	4,765	3383,2	8,8595
460	7,516	3404,5	9,0926	6,764	3404,5	9,0439	5,636	3404,4	8,9596	4,831	3404,2	8,8884
470	7,619	3425,6	9,1212	6,857	3425,6	9,0725	5,713	3425,4	8,9882	4,897	3425,3	8,9170
480	7,721	3446,8	9,1495	6,949	3446,7	9,1008	5,790	3446,6	9,0165	4,963	3446,5	8,9453
490	7,824	3468,0	9,1774	7,041	3468,0	9,1288	5,867	3467,8	9,0445	5,029	3467,7	8,9733
500	7,927	3489,3	9,2052	7,134	3489,2	9,1565	5,944	3489,1	9,0722	5,095	3489,0	9,0010
510	8,029	3510,7	9,2326	7,226	3510,6	9,1839	6,021	3510,5	9,0997	5,161	3510,4	9,0285
520	8,132	3532,1	9,2598	7,319	3532,0	9,2111	6,098	3531,9	9,1269	5,227	3531,8	9,0556
530	8,235	3553,6	9,2867	7,411	3553,5	9,2381	6,175	3553,4	9,1538	5,293	3553,3	9,0826
540	8,337	3575,1	9,3134	7,503	3575,1	9,2648	6,253	3575,0	9,1805	5,359	3574,9	9,1093
550	8,440	3596,8	9,3399	7,596	3596,7	9,2912	6,330	3596,6	9,2070	5,425	3596,6	9,1357
560	8,543	3618,5	9,3661	7,688	3618,4	9,3174	6,407	3618,4	9,2332	5,491	3618,3	9,1620
570	8,645	3640,3	9,3921	7,781	3640,2	9,3434	6,484	3640,1	9,2592	5,557	3640,0	9,1879
580	8,748	3662,1	9,4178	7,873	3662,1	9,3691	6,561	3662,0	9,2849	5,623	3661,9	9,2137
590	8,851	3684,0	9,4433	7,965	3684,0	9,3947	6,638	3683,9	9,3105	5,689	3683,8	9,2392
600	8,953	3706,0	9,4687	8,058	3706,0	9,4200	6,714	3705,9	9,3358	5,755	3705,8	9,2646
610	9,056	3728,1	9,4938	8,150	3728,0	9,4451	6,791	3727,9	9,3609	5,821	3727,9	9,2897
620	9,159	3750,2	9,5187	8,243	3750,1	9,4700	6,868	3750,1	9,3858	5,887	3750,0	9,3146
630	9,261	3772,4	9,5434	8,335	3772,3	9,4947	6,945	3772,3	9,4105	5,953	3772,2	9,3393
640	9,364	3794,6	9,5679	8,427	3794,6	9,5193	7,022	3794,5	9,4351	6,019	3794,5	9,3639
650	9,466	3817,0	9,5922	8,520	3816,9	9,5436	7,099	3816,9	9,4594	6,085	3816,8	9,3882
660	9,569	3839,4	9,6164	8,612	3839,3	9,5677	7,176	3839,3	9,4835	6,151	3839,2	9,4123
670	9,672	3861,9	9,6403	8,704	3861,8	9,5917	7,253	3861,8	9,5075	6,217	3861,7	9,4363
680	9,774	3884,4	9,6641	8,797	3884,4	9,6155	7,330	3884,3	9,5313	6,283	3884,2	9,4601
690	9,877	3907,0	9,6877	8,889	3907,0	9,6391	7,407	3906,9	9,5549	6,349	3906,9	9,4837
700	9,979	3929,7	9,7112	8,981	3929,7	9,6625	7,484	3929,6	9,5783	6,415	3929,6	9,5071
710	10,08	3952,5	9,7344	9,074	3952,4	9,6858	7,561	3952,4	9,6016	6,481	3952,3	9,5304
720	10,18	3975,3	9,7575	9,166	3975,3	9,7089	7,638	3975,2	9,6247	6,547	3975,2	9,5535
730	10,29	3998,2	9,7805	9,258	3998,2	9,7318	7,715	3998,1	9,6476	6,613	3998,1	9,5764
740	10,39	4021,2	9,8033	9,351	4021,1	9,7546	7,792	4021,1	9,6704	6,679	4021,0	9,5992
750	10,49	4044,2	9,8259	9,443	4044,2	9,7772	7,869	4044,1	9,6931	6,745	4044,1	9,6219
760	10,60	4067,3	9,8484	9,535	4067,3	9,7997	7,946	4067,2	9,7155	6,811	4067,2	9,6444
770	10,70	4090,5	9,8707	9,628	4090,5	9,8220	8,023	4090,4	9,7379	6,877	4090,4	9,6667
780	10,80	4113,7	9,8929	9,720	4113,7	9,8442	8,100	4113,7	9,7601	6,943	4113,6	9,6889
790	10,90	4137,1	9,9149	9,812	4137,0	9,8663	8,177	4137,0	9,7821	7,009	4137,0	9,7109

t	p = 45 kPa t _s = 78,71			p = 50 kPa t _s = 81,32			p = 60 kPa t _s = 85,93			p = 70 kPa t _s = 89,93		
	v' = 3,576	i' = 2640,9	s' = 7,6288	v' = 3,240	i' = 2645,2	s' = 7,5930	v' = 2,732	i' = 2652,9	s' = 7,5311	v' = 2,365	i' = 2659,4	s' = 7,4790
	v	i	s	v	i	s	v	i	s	v	i	s
0	0,0010002	0,0	-0,0002	0,0010002	0,0	-0,0002	0,0010002	0,0	-0,0002	0,0010002	0,0	-0,0001
10	0,0010003	42,1	0,1511	0,0010003	42,1	0,1511	0,0010003	42,1	0,1511	0,0010003	42,1	0,1511
20	0,0010018	84,0	0,2965	0,0010018	84,0	0,2965	0,0010018	84,0	0,2965	0,0010018	84,0	0,2965
30	0,0010044	125,8	0,4368	0,0010044	125,8	0,4368	0,0010044	125,8	0,4368	0,0010044	125,8	0,4368
800	11,00	4160,5	9,9368	9,905	4160,4	9,8882	8,254	4160,4	9,8040	7,075	4160,3	9,7328
810	11,11	4184,0	9,9586	9,997	4183,9	9,9100	8,331	4183,9	9,8258	7,141	4183,8	9,7546
820	11,21	4207,5	9,9802	10,09	4207,5	9,9316	8,408	4207,4	9,8474	7,207	4207,4	9,7762
830	11,31	4231,1	10,0017	10,18	4231,1	9,9531	8,485	4231,0	9,8689	7,273	4231,0	9,7977
840	11,41	4254,8	10,0231	10,27	4254,8	9,9745	8,562	4254,7	9,8903	7,338	4254,7	9,8191
850	11,52	4278,5	10,0443	10,37	4278,5	9,9957	8,639	4278,5	9,9115	7,404	4278,4	9,8404
860	11,62	4302,3	10,0655	10,46	4302,3	10,0168	8,716	4302,3	9,9326	7,470	4302,2	9,8615
870	11,72	4326,2	10,0864	10,55	4326,2	10,0378	8,793	4326,2	9,9536	7,536	4326,1	9,8824
880	11,83	4350,2	10,1073	10,64	4350,1	10,0586	8,869	4350,1	9,9745	7,602	4350,1	9,9033
890	11,93	4374,2	10,1280	10,74	4374,2	10,0794	8,946	4374,1	9,9952	7,668	4374,1	9,9240
900	12,03	4398,3	10,1486	10,83	4398,2	10,1000	9,023	4398,2	10,0158	7,734	4398,2	9,9447
910	12,13	4422,4	10,1691	10,92	4422,4	10,1205	9,100	4422,3	10,0363	7,800	4422,3	9,9651
920	12,24	4446,6	10,1895	11,01	4446,6	10,1409	9,177	4446,6	10,0567	7,866	4446,5	9,9855
930	12,34	4470,9	10,2098	11,10	4470,9	10,1611	9,254	4470,8	10,0770	7,932	4470,8	10,0058
940	12,44	4495,2	10,2299	11,20	4495,2	10,1813	9,331	4495,2	10,0971	7,998	4495,2	10,0259
950	12,54	4519,7	10,2500	11,29	4519,6	10,2013	9,408	4519,6	10,1172	8,064	4519,6	10,0460
960	12,65	4544,1	10,2699	11,38	4544,1	10,2213	9,485	4544,1	10,1371	8,130	4544,0	10,0659
970	12,75	4568,7	10,2897	11,47	4568,7	10,2411	9,562	4568,6	10,1569	8,196	4568,6	10,0857
980	12,85	4593,3	10,3094	11,57	4593,3	10,2608	9,639	4593,2	10,1766	8,262	4593,2	10,1055
990	12,96	4618,0	10,3290	11,66	4617,9	10,2804	9,716	4617,9	10,1962	8,328	4617,9	10,1251
1000	13,06	4642,7	10,3486	11,75	4642,7	10,2999	9,793	4642,7	10,2158	8,394	4642,6	10,1446

3-jadval (davomi)

t	p = 80 kPa t _s = 93,49			p = 90 kPa t _s = 96,69			p = 100 kPa t _s = 99,61			p = 150 kPa t _s = 111,35		
	v' = 2,087	i' = 2665,2	s' = 7,4339	v' = 1,869	i' = 2670,3	s' = 7,3942	v' = 1,694	i' = 2674,9	s' = 7,3588	v' = 1,159	i' = 2693,1	s' = 7,2229
	v	i	s	v	i	s	v	i	s	v	i	s
0	0,0010002	0,0	-0,0001	0,0010002	0,0	-0,0001	0,0010002	0,1	-0,0001	0,0010001	0,1	-0,0001
10	0,0010003	42,1	0,1511	0,0010003	42,1	0,1511	0,0010003	42,1	0,1511	0,0010003	42,2	0,1511
20	0,0010018	84,0	0,2965	0,0010018	84,0	0,2965	0,0010018	84,0	0,2965	0,0010018	84,1	0,2965
30	0,0010044	125,8	0,4368	0,0010044	125,8	0,4368	0,0010044	125,8	0,4368	0,0010043	125,9	0,4367
40	0,0010078	167,6	0,5724	0,0010078	167,6	0,5724	0,0010078	167,6	0,5724	0,0010078	167,7	0,5724
50	0,0010121	209,4	0,7038	0,0010121	209,4	0,7038	0,0010121	209,4	0,7038	0,0010121	209,5	0,7037
60	0,0010171	251,2	0,8312	0,0010171	251,2	0,8312	0,0010171	251,2	0,8312	0,0010171	251,3	0,8311
70	0,0010227	293,1	0,9550	0,0010227	293,1	0,9550	0,0010227	293,1	0,9550	0,0010227	293,1	0,9549
80	0,0010290	335,0	1,0754	0,0010290	335,0	1,0754	0,0010290	335,0	1,0754	0,0010290	335,0	1,0753
90	0,0010359	377,0	1,1927	0,0010359	377,0	1,1926	0,0010359	377,0	1,1926	0,0010359	377,0	1,1926

100	2,127	2678,5	7,4698	1,887	2677,1	7,4126	1,696	2675,8	7,3610	0,0010434	419,1	1,3070
110	2,187	2698,7	7,5232	1,941	2697,5	7,4664	1,745	2696,3	7,4154	0,0010516	461,4	1,4187
120	2,247	2718,7	7,5747	1,995	2717,6	7,5183	1,793	2716,6	7,4676	1,188	2711,3	7,2698
130	2,307	2738,5	7,6247	2,048	2737,6	7,5685	1,841	2736,7	7,5181	1,221	2732,1	7,3219
140	2,366	2758,3	7,6732	2,101	2757,5	7,6173	1,889	2756,7	7,5671	1,253	2752,6	7,3721
150	2,425	2778,0	7,7203	2,154	2777,3	7,6646	1,937	2776,6	7,6147	1,286	2772,9	7,4207
160	2,484	2797,7	7,7663	2,206	2797,1	7,7108	1,984	2796,4	7,6610	1,318	2793,1	7,4679
170	2,543	2817,4	7,8112	2,259	2816,8	7,7558	2,031	2816,2	7,7062	1,350	2813,2	7,5138
180	2,601	2837,1	7,8551	2,311	2836,5	7,7998	2,079	2836,0	7,7503	1,381	2832,2	7,5584
190	2,660	2856,7	7,8980	2,363	2856,2	7,8428	2,126	2855,7	7,7934	1,413	2853,2	7,6021
200	2,718	2876,4	7,9400	2,415	2875,9	7,8849	2,172	2875,5	7,8356	1,445	2873,1	7,6447
210	2,777	2896,1	7,9812	2,467	2895,7	7,9262	2,219	2895,2	7,8769	1,476	2893,1	7,6864
220	2,835	2915,8	8,0216	2,519	2915,4	7,9667	2,266	2915,0	7,9174	1,507	2913,0	7,7272
230	2,893	2935,6	8,0613	2,571	2935,2	8,0064	2,313	2934,8	7,9572	1,539	2933,0	7,7673
240	2,952	2955,4	8,1002	2,623	2955,0	8,0454	2,360	2954,7	7,9962	1,570	2952,9	7,8066
250	3,010	2975,2	8,1385	2,674	2974,9	8,0837	2,406	2974,5	8,0346	1,601	2972,9	7,8451
260	3,068	2995,1	8,1761	2,726	2994,8	8,1213	2,453	2994,4	8,0723	1,633	2992,9	7,8830
270	3,126	3015,0	8,2131	2,778	3014,7	8,1584	2,499	3014,4	8,1094	1,664	3013,0	7,9202
280	3,184	3034,9	8,2496	2,830	3034,7	8,1948	2,546	3034,4	8,1458	1,695	3033,0	7,9569
290	3,242	3055,0	8,2854	2,881	3054,7	8,2307	2,592	3054,4	8,1818	1,726	3053,2	7,9929
300	3,300	3075,0	8,3207	2,933	3074,8	8,2661	2,639	3074,5	8,2171	1,757	3073,3	8,0284
310	3,358	3095,2	8,3555	2,984	3094,9	8,3009	2,685	3094,7	8,2520	1,788	3093,5	8,0634
320	3,416	3115,3	8,3899	3,036	3115,1	8,3352	2,732	3114,9	8,2863	1,819	3113,8	8,0978
330	3,474	3135,6	8,4237	3,087	3135,4	8,3691	2,778	3135,1	8,3202	1,850	3134,1	8,1318
340	3,532	3155,9	8,4570	3,139	3155,7	8,4024	2,825	3155,5	8,3536	1,881	3154,4	8,1652
350	3,590	3176,2	8,4900	3,191	3176,0	8,4354	2,871	3175,8	8,3865	1,912	3174,9	8,1983
360	3,648	3196,6	8,5225	3,242	3196,4	8,4679	2,917	3196,2	8,4190	1,943	3195,3	8,2308
370	3,706	3217,1	8,5545	3,294	3216,9	8,5000	2,964	3216,7	8,4511	1,974	3215,8	8,2630
380	3,764	3237,6	8,5862	3,345	3237,4	8,5317	3,010	3237,3	8,4828	2,005	3236,4	8,2947
390	3,822	3258,2	8,6175	3,396	3258,0	8,5629	3,056	3257,9	8,5141	2,036	3257,1	8,3261
400	3,879	3278,9	8,6484	3,448	3278,7	8,5939	3,103	3278,5	8,5451	2,067	3277,8	8,3571
410	3,937	3299,6	8,6789	3,499	3299,4	8,6244	3,149	3299,3	8,5756	2,098	3298,5	8,3877
420	3,995	3320,3	8,7091	3,551	3320,2	8,6546	3,195	3320,1	8,6059	2,129	3319,3	8,4180
430	4,053	3341,2	8,7390	3,602	3341,1	8,6845	3,242	3340,9	8,6357	2,160	3340,2	8,4479
440	4,111	3362,1	8,7685	3,654	3362,0	8,7140	3,288	3361,8	8,6653	2,191	3361,2	8,4774
450	4,169	3383,1	8,7977	3,705	3382,9	8,7432	3,334	3382,8	8,6945	2,222	3382,2	8,5067
460	4,226	3404,1	8,8266	3,756	3404,0	8,7721	3,381	3403,9	8,7234	2,253	3403,2	8,5356
470	4,284	3425,2	8,8552	3,808	3425,1	8,8007	3,427	3425,0	8,7520	2,284	3424,4	8,5643
480	4,342	3446,4	8,8835	3,859	3446,3	8,8290	3,473	3446,2	8,7803	2,314	3445,6	8,5926
490	4,400	3467,6	8,9115	3,911	3467,5	8,8571	3,519	3467,4	8,8083	2,345	3466,8	8,6206
500	4,458	3488,9	8,9393	3,962	3488,8	8,8848	3,566	3488,7	8,8361	2,376	3488,2	8,6484
510	4,515	3510,3	8,9667	4,013	3510,2	8,9123	3,612	3510,1	8,8635	2,407	3509,6	8,6759
520	4,573	3531,7	8,9939	4,065	3531,6	8,9395	3,658	3531,5	8,8907	2,438	3531,0	8,7031
530	4,631	3553,2	9,0209	4,116	3553,1	8,9664	3,704	3553,0	8,9177	2,469	3552,6	8,7301
540	4,689	3574,8	9,0476	4,168	3574,7	8,9931	3,751	3574,6	8,9444	2,500	3574,2	8,7568
550	4,747	3596,5	9,0740	4,219	3596,4	9,0196	3,797	3596,3	8,9709	2,530	3595,8	8,7833
560	4,804	3618,2	9,1002	4,270	3618,1	9,0458	3,843	3618,0	8,9971	2,561	3617,6	8,8096

570	4,862	3640,0	9,1262	4,322	3639,9	9,0718	3,889	3639,8	9,0231	2,592	3639,4	8,8356
580	4,920	3661,8	9,1520	4,373	3661,7	9,0976	3,936	3661,6	9,0489	2,623	3661,2	8,8614
590	4,978	3683,7	9,1775	4,424	3683,7	9,1231	3,982	3683,6	9,0744	2,654	3683,2	8,8869
600	5,035	3705,7	9,2029	4,476	3705,6	9,1485	4,028	3705,6	9,0998	2,685	3705,2	8,9123
610	5,093	3727,8	9,2280	4,527	3727,7	9,1736	4,074	3727,6	9,1249	2,716	3727,3	8,9374
620	5,151	3749,9	9,2529	4,578	3749,8	9,1985	4,120	3749,8	9,1498	2,746	3749,4	8,9624
630	5,209	3772,1	9,2776	4,630	3772,1	9,2232	4,167	3772,0	9,1745	2,777	3771,6	8,9871
640	5,266	3794,4	9,3022	4,681	3794,3	9,2477	4,213	3794,3	9,1991	2,808	3793,9	9,0116
650	5,324	3816,7	9,3265	4,732	3816,7	9,2721	4,259	3816,6	9,2234	2,839	3816,3	9,0360
660	5,382	3839,1	9,3506	4,784	3839,1	9,2962	4,305	3839,0	9,2476	2,870	3838,7	9,0602
670	5,440	3861,6	9,3746	4,835	3861,6	9,3202	4,351	3861,5	9,2715	2,900	3861,2	9,0841
680	5,497	3884,2	9,3984	4,886	3884,1	9,3440	4,398	3884,1	9,2953	2,931	3883,8	9,1079
690	5,555	3906,8	9,4220	4,938	3906,7	9,3676	4,444	3906,7	9,3189	2,962	3906,4	9,1316
700	5,613	3929,5	9,4455	4,989	3929,4	9,3910	4,490	3929,4	9,3424	2,993	3929,1	9,1550
710	5,671	3952,3	9,4687	5,040	3952,2	9,4143	4,536	3952,1	9,3656	3,024	3951,9	9,1783
720	5,728	3975,1	9,4918	5,092	3975,0	9,4374	4,582	3975,0	9,3888	3,055	3974,7	9,2014
730	5,786	3998,0	9,5148	5,143	3997,9	9,4604	4,629	3997,9	9,4117	3,085	3997,6	9,2244
740	5,844	4021,0	9,5376	5,194	4020,9	9,4832	4,675	4020,9	9,4345	3,116	4020,6	9,2472
750	5,902	4044,0	9,5602	5,246	4044,0	9,5058	4,721	4043,9	9,4571	3,147	4043,7	9,2698
760	5,959	4067,1	9,5827	5,297	4067,1	9,5283	4,767	4067,0	9,4796	3,178	4066,8	9,2923
770	6,017	4090,3	9,6050	5,348	4090,3	9,5506	4,813	4090,2	9,5020	3,209	4090,0	9,3146
780	6,075	4113,6	9,6272	5,400	4113,5	9,5728	4,860	4113,5	9,5241	3,239	4113,2	9,3368
790	6,132	4136,9	9,6493	5,451	4136,9	9,5949	4,906	4136,8	9,5462	3,270	4136,6	9,3589
800	6,190	4160,3	9,6712	5,502	4160,3	9,6168	4,952	4160,2	9,5681	3,301	4160,0	9,3808
810	6,248	4183,8	9,6929	5,554	4183,8	9,6386	4,998	4183,7	9,5899	3,332	4183,5	9,4026
820	6,306	4207,3	9,7146	5,605	4207,3	9,6602	5,044	4207,3	9,6115	3,363	4207,0	9,4242
830	6,363	4231,0	9,7361	5,656	4230,9	9,6817	5,091	4230,9	9,6330	3,393	4230,7	9,4458
840	6,421	4254,6	9,7575	5,708	4254,6	9,7031	5,137	4254,6	9,6544	3,424	4254,4	9,4671
850	6,479	4278,4	9,7787	5,759	4278,3	9,7243	5,183	4278,3	9,6757	3,455	4278,1	9,4884
860	6,537	4302,2	9,7998	5,810	4302,2	9,7454	5,229	4302,1	9,6968	3,486	4301,9	9,5095
870	6,594	4326,1	9,8208	5,861	4326,0	9,7664	5,275	4326,0	9,7177	3,517	4325,8	9,5305
880	6,652	4350,0	9,8416	5,913	4350,0	9,7873	5,321	4350,0	9,7386	3,547	4349,8	9,5513
890	6,710	4374,0	9,8624	5,964	4374,0	9,8080	5,368	4374,0	9,7593	3,578	4373,8	9,5721
900	6,767	4398,1	9,8830	6,015	4398,1	9,8286	5,414	4398,1	9,7800	3,609	4397,9	9,5927
910	6,825	4422,3	9,9035	6,067	4422,2	9,8491	5,460	4422,2	9,8005	3,640	4422,0	9,6132
920	6,883	4446,5	9,9239	6,118	4446,5	9,8695	5,506	4446,4	9,8208	3,671	4446,3	9,6336
930	6,941	4470,8	9,9441	6,169	4470,7	9,8898	5,552	4470,7	9,8411	3,701	4470,5	9,6539
940	6,998	4495,1	9,9643	6,221	4495,1	9,9099	5,598	4495,1	9,8613	3,732	4494,9	9,6740
950	7,056	4519-5	9,9843	6,272	4519,5	9,9300	5,645	4519,5	9,8813	3,763	4519,3	9,6941
960	7,114	4544,0	10,0043	6,323	4544,0	9,9499	5,691	4544,0	9,9012	3,794	4543,8	9,7140
970	7,171	4568,6	10,0241	6,375	4568,5	9,9697	5,737	4568,5	9,9211	3,825	4568,3	9,7338
980	7,229	4593,2	10,0438	6,426	4593,1	9,9894	5,783	4593,1	9,9408	3,855	4593,0	9,7535
990	7,287	4617,9	10,0634	6,477	4617,8	10,0090	5,829	4617,8	9,9604	3,886	4617,6	9,7732
1000	7,345	4642,6	10,0829	6,528	4642,6	10,0286	5,876	4642,5	9,9799	3,917	4642,4	9,7927

3-jadval (davomi)

t	p = 200 kPa t _g = 120,21			p = 250 kPa t _g = 127,41			p = 300 kPa t _g = 133,53			p = 350 kPa t _g = 138,86		
	v [*] = 0,8857	i [*] = 2706,2	s [*] = 7,1269	v [*] = 0,7187	i [*] = 2716,5	s [*] = 7,0524	v [*] = 0,6058	i [*] = 2724,9	s [*] = 6,9916	v [*] = 0,5242	i [*] = 2732,0	s [*] = 6,9401
	v	i	s	v	i	s	v	i	s	v	i	s
0	0,0010001	0,2	-0,0001	0,0010001	0,2	-0,0001	0,0010001	0,3	-0,0001	0,0010000	0,3	-0,0001
10	0,0010003	42,2	0,1511	0,0010002	42,3	0,1511	0,0010002	42,3	0,1511	0,0010002	42,4	0,1511
20	0,0010018	84,1	0,2965	0,0010017	84,2	0,2965	0,0010017	84,2	0,2964	0,0010017	84,2	0,2964
30	0,0010043	125,9	0,4367	0,0010043	126,0	0,4367	0,0010043	126,0	0,4367	0,0010043	126,1	0,4367
40	0,0010078	167,7	0,5724	0,0010078	167,8	0,5723	0,0010077	167,8	0,5723	0,0010077	167,8	0,5723
50	0,0010121	209,5	0,7037	0,0010120	209,5	0,7037	0,0010120	209,6	0,7037	0,0010120	209,6	0,7036
60	0,0010170	251,3	0,8311	0,0010170	251,3	0,8311	0,0010170	251,4	0,8311	0,0010170	251,4	0,8310
70	0,0010227	293,2	0,9549	0,0010227	293,2	0,9549	0,0010226	293,2	0,9548	0,0010226	293,3	0,9548
80	0,0010290	335,1	1,0753	0,0010289	335,1	1,0753	0,0010289	335,1	1,0752	0,0010289	335,2	1,0752
90	0,0010359	377,1	1,1926	0,0010359	377,1	1,1925	0,0010358	377,1	1,1925	0,0010358	377,2	1,1925
100	0,0010434	419,2	1,3069	0,0010434	419,2	1,3069	0,0010434	419,2	1,3069	0,0010433	419,3	1,3068
110	0,0010516	461,4	1,4186	0,0010515	461,4	1,4186	0,0010515	461,5	1,4185	0,0010515	461,5	1,4185
120	0,0010603	503,8	1,5278	0,0010603	503,8	1,5278	0,0010603	503,9	1,5277	0,0010602	503,9	1,5277
130	0,9104	2727,3	7,1796	0,7240	2722,2	7,0666	0,0010697	546,4	1,6346	0,0010697	546,4	1,6346
140	0,9353	2748,3	7,2312	0,7444	2743,9	7,1198	0,6170	2739,4	7,0269	0,5259	2734,6	6,9464
150	0,9599	2769,1	7,2809	0,7644	2765,2	7,1707	0,6340	2761,2	7,0791	0,5408	2757,1	7,0002
160	0,9843	2789,7	7,3290	0,7842	2786,2	7,2197	0,6508	2782,6	7,1291	0,5555	2778,9	7,0513
170	1,0085	2810,1	7,3756	0,8039	2806,9	7,2671	0,6674	2803,7	7,1773	0,5699	2800,4	7,1004
180	1,0326	2830,4	7,4209	0,8234	2827,5	7,3130	0,6839	2824,6	7,2239	0,5842	2821,7	7,1477
190	1,0566	2850,6	7,4650	0,8428	2848,0	7,3577	0,7002	2845,4	7,2692	0,5984	2842,7	7,1935
200	1,0805	2870,8	7,5081	0,8621	2868,4	7,4013	0,7164	2866,0	7,3132	0,6124	2863,5	7,2381
210	1,1043	2890,9	7,5502	0,8813	2888,7	7,4437	0,7326	2886,5	7,3561	0,6263	2884,2	7,2814
220	1,1281	2911,0	7,5914	0,9004	2909,0	7,4852	0,7486	2906,9	7,3979	0,6402	2904,8	7,3236
230	1,1517	2931,1	7,6317	0,9195	2929,2	7,5259	0,7646	2927,3	7,4388	0,6540	2925,3	7,3648
240	1,1753	2951,2	7,6712	0,9385	2949,4	7,5656	0,7806	2947,6	7,4789	0,6678	2945,8	7,4051
250	1,1989	2971,3	7,7100	0,9574	2969,6	7,6046	0,7965	2967,9	7,5181	0,6815	2966,3	7,4445
260	1,2224	2991,4	7,7481	0,9764	2989,8	7,6429	0,8123	2988,2	7,5566	0,6951	2986,7	7,4832
270	1,2459	3011,5	7,7855	0,9952	3010,0	7,6805	0,8281	3008,6	7,5943	0,7087	3007,1	7,5211
280	1,2694	3031,7	7,8223	1,0141	3030,3	7,7174	0,8439	3028,9	7,6314	0,7223	3027,5	7,5584
290	1,2928	3051,9	7,8584	1,0329	3050,5	7,7537	0,8596	3049,2	7,6679	0,7358	3047,9	7,5950
300	1,3162	3072,1	7,8940	1,0517	3070,8	7,7895	0,8753	3069,6	7,7037	0,7494	3068,4	7,6310
310	1,3396	3092,4	7,9291	1,0705	3091,2	7,8246	0,8910	3090,0	7,7390	0,7629	3088,8	7,6663
320	1,3630	3112,7	7,9636	1,0892	3111,6	7,8593	0,9067	3110,4	7,7737	0,7763	3109,3	7,7012
330	1,3863	3133,0	7,9977	1,1079	3132,0	7,8934	0,9224	3130,9	7,8079	0,7898	3129,8	7,7355
340	1,4097	3153,4	8,0312	1,1267	3152,4	7,9270	0,9380	3151,4	7,8417	0,8032	3150,4	7,7693
350	1,4330	3173,9	8,0643	1,1454	3172,9	7,9602	0,9536	3172,0	7,8749	0,8167	3171,0	7,8026
360	1,4563	3194,4	8,0970	1,1640	3193,5	7,9929	0,9692	3192,6	7,9077	0,8301	3191,6	7,8355
370	1,4795	3215,0	8,1292	1,1827	3214,1	8,0252	0,9848	3213,2	7,9400	0,8435	3212,3	7,8679
380	1,5028	3235,6	8,1610	1,2014	3234,7	8,0571	1,0004	3233,9	7,9720	0,8569	3233,0	7,8999
390	1,5261	3256,3	8,1924	1,2200	3255,4	8,0885	1,0160	3254,6	8,0035	0,8702	3253,8	7,9314
400	1,5493	3277,0	8,2235	1,2387	3276,2	8,1196	1,0315	3275,4	8,0346	0,8836	3274,6	7,9626

t	p = 200 kPa t _p = 120,21			p = 250 kPa t _p = 127,41			p = 300 kPa t _p = 133,53			p = 350 kPa t _p = 138,86		
	v [*] = 0,8857	i [*] = 2706,2	s [*] = 7,1269	v [*] = 0,7187	i [*] = 2716,5	s [*] = 7,0524	v [*] = 0,6058	i [*] = 2724,9	s [*] = 6,9916	v [*] = 0,5242	i [*] = 2732,0	s [*] = 6,9401
	v	i	s	v	i	s	v	i	s	v	i	s
410	1,5726	3297,8	8,2541	1,2573	3297,0	8,1503	1,0471	3296,3	8,0654	0,8969	3295,5	7,9934
420	1,5958	3318,6	8,2844	1,2759	3317,9	8,1807	1,0626	3317,2	8,0957	0,9103	3316,5	8,0238
430	1,6190	3339,5	8,3144	1,2945	3338,8	8,2106	1,0782	3338,1	8,1258	0,9236	3337,5	8,0539
440	1,6423	3360,5	8,3440	1,3131	3359,8	8,2403	1,0937	3359,2	8,1554	0,9370	3358,5	8,0836
450	1,6655	3381,5	8,3733	1,3317	3380,9	8,2696	1,1092	3380,2	8,1848	0,9503	3379,6	8,1130
460	1,6887	3402,6	8,4022	1,3503	3402,0	8,2986	1,1247	3401,4	8,2138	0,9636	3400,8	8,1421
470	1,7119	3423,8	8,4309	1,3689	3423,2	8,3273	1,1402	3422,6	8,2426	0,9769	3422,0	8,1708
480	1,7351	3445,0	8,4593	1,3875	3444,4	8,3557	1,1557	3443,8	8,2710	0,9902	3443,3	8,1993
490	1,7583	3466,3	8,4873	1,4060	3465,7	8,3838	1,1712	3465,2	8,2991	1,0035	3464,6	8,2274
500	1,7814	3487,6	8,5151	1,4246	3487,1	8,4116	1,1867	3486,6	8,3269	1,0168	3486,0	8,2553
510	1,8046	3509,1	8,5426	1,4432	3508,5	8,4392	1,2022	3508,0	8,3545	1,0301	3507,5	8,2829
520	1,8278	3530,5	8,5699	1,4617	3530,0	8,4664	1,2177	3529,5	8,3818	1,0434	3529,0	8,3102
530	1,8510	3552,1	8,5969	1,4803	3551,6	8,4935	1,2332	3551,1	8,4089	1,0567	3550,6	8,3373
540	1,8741	3573,7	8,6236	1,4988	3573,2	8,5202	1,2486	3572,8	8,4356	1,0699	3572,3	8,3641
550	1,8973	3595,4	8,6501	1,5174	3594,9	8,5467	1,2641	3594,5	8,4622	1,0832	3594,0	8,3906
560	1,9204	3617,1	8,6764	1,5359	3616,7	8,5730	1,2796	3616,2	8,4885	1,0965	3615,8	8,4169
570	1,9436	3638,9	8,7024	1,5545	3638,5	8,5991	1,2950	3638,1	8,5145	1,1097	3637,7	8,4430
580	1,9667	3660,8	8,7282	1,5730	3660,4	8,6249	1,3105	3660,0	8,5404	1,1230	3659,6	8,4689
590	1,9899	3682,8	8,7538	1,5915	3682,4	8,6505	1,3260	3682,0	8,5660	1,1363	3681,6	8,4945
600	2,0130	3704,8	8,7792	1,6101	3704,4	8,6759	1,3414	3704,0	8,5914	1,1495	3703,6	8,5199
610	2,0362	3726,9	8,8043	1,6286	3726,5	8,7010	1,3569	3726,1	8,6165	1,1628	3725,8	8,5451
620	2,0593	3749,0	8,8293	1,6471	3748,7	8,7260	1,3723	3748,3	8,6415	1,1760	3747,9	8,5701
630	2,0825	3771,3	8,8540	1,6656	3770,9	8,7507	1,3877	3770,6	8,6663	1,1893	3770,2	8,5948
640	2,1056	3793,6	8,8786	1,6842	3793,2	8,7753	1,4032	3792,9	8,6909	1,2025	3792,5	8,6194
650	2,1287	3815,9	8,9029	1,7027	3815,6	8,7997	1,4186	3815,3	8,7152	1,2157	3814,9	8,6438
660	2,1519	3838,4	8,9271	1,7212	3838,0	8,8239	1,4341	3837,7	8,7394	1,2290	3837,4	8,6680
670	2,1750	3860,9	8,9511	1,7397	3860,6	8,8479	1,4495	3860,2	8,7634	1,2422	3859,9	8,6920
680	2,1981	3883,4	8,9749	1,7582	3883,1	8,8717	1,4649	3882,8	8,7873	1,2555	3882,5	8,7159
690	2,2212	3906,1	8,9985	1,7767	3905,8	8,8953	1,4804	3905,5	8,8109	1,2687	3905,2	8,7395
700	2,2444	3928,8	9,0220	1,7952	3928,5	8,9188	1,4958	3928,2	8,8344	1,2819	3927,9	8,7630
710	2,2675	3951,6	9,0453	1,8137	3951,3	8,9421	1,5112	3951,0	8,8577	1,2952	3950,7	8,7863
720	2,2906	3974,4	9,0684	1,8322	3974,2	8,9652	1,5267	3973,9	8,8808	1,3084	3973,6	8,8095
730	2,3137	3997,4	9,0914	1,8507	3997,1	8,9882	1,5421	3996,8	8,9038	1,3216	3996,5	8,8325
740	2,3368	4020,3	9,1142	1,8693	4020,1	9,0110	1,5575	4019,8	8,9266	1,3349*	4019,6	8,8553
750	2,3600	4043,4	9,1368	1,8878	4043,2	9,0337	1,5729	4042,9	8,9493	1,3481	4042,6	8,8780
760	2,3831	4066,5	9,1593	1,9063	4066,3	9,0562	1,5884	4066,0	8,9718	1,3613	4065,8	8,9005
770	2,4062	4089,7	9,1817	1,9248	4089,5	9,0785	1,6038	4089,3	8,9942	1,3745	4089,0	8,9229
780	2,4293	4113,0	9,2039	1,9432	4112,8	9,1007	1,6192	4112,5	9,0164	1,3878	4112,3	8,9451
790	2,4524	4136,3	9,2259	1,9617	4136,1	9,1228	1,6346	4135,9	9,0385	1,4010	4135,7	8,9671
800	2,4755	4159,8	9,2479	1,9802	4159,5	9,1447	1,6500	4159,3	9,0604	1,4142	4159,1	8,9891
810	2,4986	4183,3	9,2697	1,9987	4183,0	9,1665	1,6655	4182,8	9,0822	1,4274	4182,6	9,0109
820	2,5218	4206,8	9,2913	2,0172	4206,6	9,1882	1,6809	4206,4	9,1039	1,4406	4206,2	9,0326
830	2,5449	4230,5	9,3128	2,0357	4230,2	9,2097	1,6963	4230,0	9,1254	1,4539	4229,8	9,0541
840	2,5680	4254,1	9,3342	2,0542	4253,9	9,2311	1,7117	4253,7	9,1468	1,4671	4253,5	9,0755
850	2,5911	4277,9	9,3555	2,0727	4277,7	9,2523	1,7271	4277,5	9,1680	1,4803	4277,3	9,0967
860	2,6142	4301,7	9,3766	2,0912	4301,5	9,2734	1,7425	4301,3	9,1892	1,4935	4301,1	9,1179
870	2,6373	4325,6	9,3976	2,1097	4325,4	9,2944	1,7580	4325,2	9,2102	1,5067	4325,0	9,1389
880	2,6604	4349,6	9,4184	2,1282	4349,4	9,3153	1,7734	4349,2	9,2310	1,5199	4349,0	9,1597
890	2,6835	4373,6	9,4392	2,1467	4373,4	9,3361	1,7888	4373,2	9,2518	1,5332	4373,0	9,1805

t	p = 200 kPa $t_s = 120,21$			p = 250 kPa $t_s = 127,41$			p = 300 kPa $t_s = 133,53$			p = 350 kPa $t_s = 138,86$		
	v''=	i''=	s''=	v''=	i''=	s''=	v''=	i''=	s''=	v''=	i''=	s''=
	0,8857	2706,2	7,1269	0,7187	2716,5	7,0524	0,6658	2724,9	6,9916	0,5242	2732,0	6,9401
	v	i	s	v	i	s	v	i	s	v	i	s
900	2,7066	4397,7	9,4598	2,1652	4397,5	9,3567	1,8042	4397,3	9,2724	1,5464	4397,2	9,2011
910	2,7297	4421,9	9,4803	2,1836	4421,7	9,3772	1,8196	4421,5	9,2929	1,5596	4421,3	9,2217
920	2,7528	4446,1	9,5007	2,2021	4445,9	9,3976	1,8350	4445,7	9,3133	1,5728	4445,6	9,2420
930	2,7759	4470,4	9,5210	2,2206	4470,2	9,4179	1,8504	4470,0	9,3336	1,5860	4469,9	9,2623
940	2,7990	4494,7	9,5411	2,2391	4494,6	9,4380	1,8658	4494,4	9,3538	1,5992	4494,2	9,2825
950	2,8221	4519,1	9,5612	2,2576	4519,0	9,4581	1,8812	4518,8	9,3738	1,6124	4518,7	9,3026
960	2,8452	4543,6	9,5811	2,2761	4543,5	9,4780	1,8966	4543,3	9,3938	1,6256	4543,2	9,3225
970	2,8683	4568,2	9,6009	2,2945	4568,0	9,4979	1,9120	4567,9	9,4136	1,6388	4567,7	9,3423
980	2,8914	4592,8	9,6207	2,3130	4592,7	9,5176	1,9275	4592,5	9,4333	1,6520	4592,4	9,3621
990	2,9145	4617,5	9,6403	2,3315	4617,3	9,5372	1,9429	4617,2	9,4530	1,6652	4617,0	9,3817
1000	2,9376	4642,2	9,6598	2,3500	4642,1	9,5567	1,9583	4642,0	9,4725	1,6785	4641,8	9,4012

3-jadval (davomi)

t	p = 400 kPa $t_s = 143,61$			p = 450 kPa $t_s = 147,91$			p = 500 kPa $t_s = 151,84$			p = 600 kPa $t_s = 158,83$		
	v''=	i''=	s''=	v''=	i''=	s''=	v''=	i''=	s''=	v''=	i''=	s''=
	0,4624	2738,1	6,8954	0,4139	2743,4	6,8560	0,3748	2748,1	6,8206	0,3156	2756,1	6,7592
	v	i	s	v	i	s	v	i	s	v	i	s
0	0,0010000	0,4	- 0,0001	0,0010000	0,4	- 0,0001	0,0010000	0,5	- 0,0001	0,0009999	0,6	- 0,0001
10	0,0010002	42,4	0,1510	0,0010001	42,5	0,1510	0,0010001	42,5	0,1510	0,0010001	42,6	0,1510
20	0,0010017	84,3	0,2964	0,0010016	84,3	0,2964	0,0010016	84,4	0,2964	0,0010016	84,5	0,2964
30	0,0010042	126,1	0,4367	0,0010042	126,2	0,4367	0,0010042	126,2	0,4366	0,0010041	126,3	0,4366
40	0,0010077	167,9	0,5723	0,0010077	167,9	0,5723	0,0010077	168,0	0,5722	0,0010076	168,1	0,5722
50	0,0010120	209,7	0,7036	0,0010119	209,7	0,7036	0,0010119	209,8	0,7036	0,0010119	209,8	0,7035
60	0,0010169	251,5	0,8310	0,0010169	251,5	0,8310	0,0010169	251,6	0,8310	0,0010169	251,6	0,8309
70	0,0010226	293,3	0,9548	0,0010226	293,4	0,9547	0,0010225	293,4	0,9547	0,0010225	293,5	0,9547
80	0,0010289	335,2	1,0752	0,0010289	335,3	1,0751	0,0010288	335,3	1,0751	0,0010288	335,4	1,0750
90	0,0010358	377,2	1,1924	0,0010358	377,3	1,1924	0,0010357	377,3	1,1923	0,0010357	377,4	1,1923
100	0,0010433	419,3	1,3068	0,0010433	419,4	1,3067	0,0010433	419,4	1,3067	0,0010432	419,5	1,3066
110	0,0010514	461,6	1,4185	0,0010514	461,6	1,4184	0,0010514	461,6	1,4184	0,0010513	461,7	1,4183
120	0,0010602	503,9	1,5276	0,0010602	504,0	1,5276	0,0010602	504,0	1,5275	0,0010601	504,1	1,5275
130	0,0010696	546,5	1,6345	0,0010696	546,5	1,6345	0,0010696	546,5	1,6344	0,0010695	546,6	1,6343
140	0,0010797	589,2	1,7392	0,0010797	589,3	1,7392	0,0010797	589,3	1,7391	0,0010796	589,4	1,7390
150	0,4709	2752,8	6,9305	0,4164	2748,3	6,8677	0,0010905	632,3	1,8419	0,0010904	632,3	1,8418
160	0,4839	2775,2	6,9828	0,4282	2771,3	6,9214	0,3837	2767,4	6,8655	0,3167	2759,0	6,7658
170	0,4968	2797,1	7,0328	0,4398	2793,7	6,9724	0,3943	2790,2	6,9176	0,3258	2783,0	6,8205
180	0,5094	2818,6	7,0809	0,4512	2815,6	7,0213	0,4047	2812,4	6,9672	0,3347	2806,0	6,8720
190	0,5219	2839,9	7,1274	0,4625	2837,1	7,0683	0,4149	2834,3	7,0150	0,3435	2828,6	6,9211
200	0,5343	2861,0	7,1724	0,4736	2858,5	7,1139	0,4250	2855,9	7,0611	0,3521	2850,7	6,9684
210	0,5467	2881,9	7,2161	0,4847	2879,6	7,1581	0,4351	2877,2	7,1057	0,3606	2872,5	7,0139
220	0,5589	2902,7	7,2587	0,4956	2900,6	7,2010	0,4450	2898,4	7,1491	0,3690	2894,0	7,0581
230	0,5710	2923,4	7,3002	0,5065	2921,4	7,2429	0,4549	2919,4	7,1912	0,3774	2915,4	7,1010
240	0,5831	2944,0	7,3408	0,5173	2942,2	7,2837	0,4647	2940,3	7,2324	0,3857	2936,6	7,1427
250	0,5952	2964,6	7,3805	0,5281	2962,8	7,3237	0,4744	2961,1	7,2726	0,3939	2957,7	7,1834

t	p = 400 kPa $t_g = 143,61$			p = 450 kPa $t_g = 147,91$			p = 500 kPa $t_g = 515,84$			p = 600 kPa $t_g = 158,83$		
	$v'' =$ 0,4624	$i'' =$ 2738,1	$s'' =$ 6,8954	$v'' =$ 0,4139	$i'' =$ 2743,4	$s'' =$ 6,8560	$v'' =$ 0,3748	$i'' =$ 2748,1	$s'' =$ 6,8206	$v'' =$ 0,3156	$i'' =$ 2756,1	$s'' =$ 6,7592
	v	i	s	v	i	s	v	i	s	v	i	s
260	0,6072	2985,1	7,4194	0,5388	2983,5	7,3627	0,4841	2981,9	7,3119	0,4021	2978,6	7,2231
270	0,6192	3005,6	7,4575	0,5495	3004,1	7,4010	0,4938	3002,6	7,3503	0,4102	2999,6	7,2620
280	0,6311	3026,1	7,4949	0,5602	3024,7	7,4386	0,5034	3023,3	7,3881	0,4183	3020,4	7,3001
290	0,6430	3046,6	7,5316	0,5708	3045,3	7,4755	0,5130	3043,9	7,4231	0,4264	3041,3	7,3374
300	0,6549	3067,1	7,5677	0,5814	3065,9	7,5117	0,5226	3064,6	7,4614	0,4344	3062,1	7,3740
310	0,6667	3087,6	7,6032	0,5920	3086,4	7,5473	0,5321	3085,3	7,4972	0,4424	3082,9	7,4100
320	0,6786	3108,2	7,6381	0,6025	3107,1	7,5824	0,5417	3105,9	7,5323	0,4504	3103,7	7,4453
330	0,6904	3128,8	7,6725	0,6130	3127,7	7,6169	0,5512	3126,6	7,5669	0,4584	3124,5	7,4801
340	0,7022	3149,4	7,7064	0,6236	3148,3	7,6508	0,5607	3147,3	7,6010	0,4663	3145,3	7,5143
350	0,7139	3170,0	7,7398	0,6341	3169,0	7,6843	0,5701	3168,1	7,6345	0,4743	3166,1	7,5480
360	0,7257	3190,7	7,7728	0,6445	3189,8	7,7173	0,5796	3188,8	7,6676	0,4822	3187,0	7,5812
370	0,7375	3211,4	7,8052	0,6550	3210,5	7,7498	0,5890	3209,6	7,7002	0,4901	3207,8	7,6140
380	0,7492	3232,2	7,8373	0,6655	3231,3	7,7819	0,5985	3230,5	7,7323	0,4980	3228,8	7,6463
390	0,7609	3253,0	7,8689	0,6759	3252,2	7,8136	0,6079	3251,4	7,7641	0,5059	3249,7	7,6781
400	0,7726	3273,9	7,9001	0,6863	3273,1	7,8449	0,6173	3272,3	7,7954	0,5137	3270,7	7,7095
410	0,7843	3294,8	7,9310	0,6968	3294,0	7,8758	0,6267	3293,3	7,8263	0,5216	3291,8	7,7405
420	0,7960	3315,7	7,9614	0,7072	3315,0	7,9063	0,6361	3314,3	7,8569	0,5294	3312,8	7,7712
430	0,8077	3336,6	7,9915	0,7176	3336,1	7,9364	0,6455	3335,4	7,8871	0,5373	3334,0	7,8014
440	0,8194	3357,8	8,0213	0,7280	3357,2	7,9662	0,6548	3356,5	7,9169	0,5451	3355,1	7,8314
450	0,8311	3379,0	8,0507	0,7384	3378,3	7,9957	0,6642	3377,7	7,9464	0,5530	3376,4	7,8609
460	0,8428	3400,1	8,0798	0,7488	3399,5	8,0248	0,6736	3398,9	7,9756	0,5608	3397,7	7,8901
470	0,8544	3421,4	8,1086	0,7591	3420,8	8,0536	0,6829	3420,2	8,0044	0,5686	3419,0	7,9190
480	0,8661	3442,7	8,1371	0,7695	3442,1	8,0821	0,6923	3441,5	8,0329	0,5764	3440,4	7,9476
490	0,8777	3464,1	8,1652	0,7799	3463,5	8,1103	0,7016	3462,9	8,0612	0,5842	3461,8	7,9759
500	0,8894	3485,5	8,1931	0,7902	3484,9	8,1383	0,7109	3484,4	8,0891	0,5920	3483,3	8,0039
510	0,9010	3507,0	8,2207	0,8006	3506,5	8,1659	0,7203	3505,9	8,1168	0,5998	3504,9	8,0316
520	0,9126	3528,5	8,2481	0,8110	3528,0	8,1933	0,7296	3527,5	8,1442	0,6076	3526,5	8,0591
530	0,9243	3550,1	8,2752	0,8213	3549,6	8,2204	0,7389	3549,2	8,1713	0,6154	3548,2	8,0862
540	0,9359	3571,8	8,3020	0,8316	3571,3	8,2472	0,7483	3570,9	8,1981	0,6232	3569,9	8,1131
550	0,9475	3593,6	8,3286	0,8420	3593,1	8,2738	0,7576	3592,6	8,2247	0,6309	3591,7	8,1398
560	0,9591	3615,4	8,3549	0,8523	3614,9	8,3001	0,7669	3614,5	8,2511	0,6387	3613,6	8,1662
570	0,9708	3637,2	8,3810	0,8627	3636,8	8,3262	0,7762	3636,4	8,2772	0,6465	3635,5	8,1923
580	0,9824	3659,2	8,4069	0,8730	3658,8	8,3521	0,7855	3658,3	8,3031	0,6542	3657,5	8,2183
590	0,9940	3681,2	8,4325	0,8833	3680,8	8,3778	0,7948	3680,4	8,3288	0,6620	3679,6	8,2439
600	1,0056	3703,2	8,4579	0,8936	3702,8	8,4032	0,8041	3702,5	8,3543	0,6698	3701,7	8,2694
610	1,0172	3725,4	8,4831	0,9040	3725,0	8,4284	0,8134	3724,6	8,3795	0,6775	3723,9	8,2947
620	1,0288	3747,6	8,5081	0,9143	3747,2	8,4534	0,8227	3746,8	8,4045	0,6853	3746,1	8,3197
630	1,0404	3769,8	8,5329	0,9246	3769,5	8,4783	0,8320	3769,1	8,4293	0,6930	3768,4	8,3446
640	1,0520	3792,2	8,5575	0,9349	3791,8	8,5029	0,8413	3791,5	8,4539	0,7008	3790,8	8,3692
650	1,0636	3814,6	8,5819	0,9452	3814,3	8,5273	0,8506	3813,9	8,4784	0,7085	3813,2	8,3937
660	1,0752	3837,1	8,6061	0,9555	3836,7	8,5515	0,8598	3836,4	8,5026	0,7163	3835,8	8,4179
670	1,0868	3859,6	8,6302	0,9659	3859,3	8,5755	0,8691	3859,0	8,5266	0,7240	3858,3	8,4420
680	1,0984	3882,2	8,6540	0,9762	3881,9	8,5994	0,8784	3881,6	8,5505	0,7318	3881,0	8,4659
690	1,1099	3904,9	8,6777	0,9865	3904,6	8,6231	0,8877	3904,3	8,5742	0,7395	3903,7	8,4896

t	p = 400 kPa t _g = 143,61			p = 450 kPa t _g = 147,91			p = 500 kPa t _g = 151,84			p = 600 kPa t _g = 158,83		
	v [*]	i [*]	s [*]	v [*]	i [*]	s [*]	v [*]	i [*]	s [*]	v [*]	i [*]	s [*]
	0,4624	2738,1	6,8954	0,4139	2743,4	6,8560	0,3748	2748,1	6,8206	0,3156	2756,1	6,7592
	v	i	s	v	i	s	v	i	s	v	i	s
700	1,1215	3927,6	8,7012	0,9968	3927,3	8,6466	0,8970	3927,0	8,5977	0,7473	3926,5	8,5131
710	1,1331	3950,4	8,7245	1,0071	3950,2	8,6699	0,9062	3949,9	8,6210	0,7550	3949,3	8,5364
720	1,1447	3973,3	8,7476	1,0174	3973,0	8,6931	0,9155	3972,8	8,6442	0,7627	3972,2	8,5596
730	1,1563	3996,3	8,7706	1,0277	3996,0	8,7161	0,9248	3995,7	8,6672	0,7705	3995,2	8,5827
740	1,1679	4019,3	8,7935	1,0380	4019,0	8,7389	0,9341	4018,8	8,6901	0,7782	4018,2	8,6055
750	1,1794	4042,4	8,8161	1,0483	4042,1	8,7616	0,9433	4041,9	8,7128	0,7859	4041,4	8,6282
760	1,1910	4065,5	8,8387	1,0586	4065,3	8,7841	0,9526	4065,0	8,7353	0,7937	4064,5	8,6508
770	1,2026	4088,8	8,8610	1,0689	4088,5	8,8065	0,9619	4088,3	8,7577	0,8014	4087,8	8,6732
780	1,2142	4112,1	8,8833	1,0791	4111,8	8,8287	0,9711	4111,6	8,7799	0,8091	4111,1	8,6954
790	1,2257	4135,4	8,9053	1,0894	4135,2	8,8508	0,9804	4135,0	8,8020	0,8168	4134,5	8,7175
800	1,2373	4158,9	8,9273	1,0997	4158,6	8,8728	0,9897	4158,4	8,8240	0,8246	4157,9	8,7395
810	1,2489	4182,4	8,9491	1,1100	4182,2	8,8946	0,9989	4181,9	8,8458	0,8323	4181,5	8,7613
820	1,2605	4206,0	8,9708	1,1203	4205,7	8,9162	1,0082	4205,5	8,8675	0,8400	4205,1	8,7830
830	1,2720	4229,6	8,9923	1,1306	4229,4	8,9378	1,0175	4229,2	8,8890	0,8478	4228,8	8,8045
840	1,2836	4253,3	9,0137	1,1409	4253,1	8,9592	1,0267	4252,9	8,9104	0,8555	4252,5	8,8260
850	1,2952	4277,1	9,0350	1,1512	4276,9	8,9805	1,0360	4276,7	8,9317	0,8632	4276,3	8,8472
860	1,3067	4300,9	9,0561	1,1615	4300,7	9,0016	1,0452	4300,5	8,9528	0,8709	4300,1	8,8684
870	1,3183	4324,8	9,0771	1,1717	4324,7	9,0226	1,0545	4324,5	8,9738	0,8786	4324,1	8,8894
880	1,3299	4348,8	9,0980	1,1820	4348,6	9,0435	1,0638	4348,4	8,9947	0,8864	4348,1	8,9103
890	1,3414	4372,9	9,1187	1,1923	4372,7	9,0642	1,0730	4372,5	9,0155	0,8941	4372,1	8,9311
900	1,3530	4397,0	9,1394	1,2026	4396,8	9,0849	1,0823	4396,6	9,0361	0,9018	4396,2	8,9517
910	1,3646	4421,1	9,1599	1,2129	4421,0	9,1054	1,0915	4420,8	9,0567	0,9095	4420,4	8,9723
920	1,3761	4445,4	9,1803	1,2232	4445,2	9,1258	1,1008	4445,0	9,0771	0,9172	4444,7	8,9927
930	1,3877	4469,7	9,2006	1,2334	4469,5	9,1461	1,1100	4469,4	9,0974	0,9249	4469,0	9,0130
940	1,3992	4494,1	9,2208	1,2437	4493,9	9,1663	1,1193	4493,7	9,1175	0,9327	4493,4	9,0332
950	1,4108	4518,5	9,2408	1,2540	4518,3	9,1863	1,1285	4518,2	9,1376	0,9404	4517,8	9,0532
960	1,4224	4543,0	9,2608	1,2643	4542,8	9,2063	1,1378	4542,7	9,1576	0,9481	4542,4	9,0732
970	1,4339	4567,6	9,2806	1,2746	4567,4	9,2261	1,1471	4567,3	9,1774	0,9558	4566,9	9,0930
980	1,4455	4592,2	9,3003	1,2848	4592,0	9,2459	1,1563	4591,9	9,1971	0,9635	4591,6	9,1128
990	1,4570	4616,9	9,3200	1,2951	4616,7	9,2655	1,1656	4616,6	9,2168	0,9712	4616,3	9,1324
1000	1,4686	4641,7	9,3395	1,3054	4641,5	9,2850	1,1748	4641,4	9,2363	0,9789	4641,1	9,1520

3-jadval (davomi)

t	p = 700 kPa t _g = 164,95			p = 800 kPa t _g = 170,41			p = 900 kPa t _g = 175,89			p = 1,00 MPa t _g = 179,89		
	v [*]	i [*]	s [*]	v [*]	i [*]	s [*]	v [*]	i [*]	s [*]	v [*]	i [*]	s [*]
	0,2728	2762,7	6,7070	0,2403	2768,3	6,6615	0,2149	2773,0	6,6212	0,1943	2777,1	6,45450
	v	i	s	v	i	s	v	i	s	v	i	s
0	0,00099999	0,7	-0,0001	0,00099998	0,8	-0,0001	0,00099997	0,9	-0,0001	0,00099997	1,0	-0,0001
10	0,0010000	42,7	0,1510	0,0010000	42,8	0,1510	0,00099999	42,9	0,1510	0,00099999	43,0	0,1510
20	0,0010015	84,6	0,2964	0,0010015	84,7	0,2963	0,0010014	84,8	0,2963	0,0010014	84,9	0,2963
30	0,0010041	126,4	0,4366	0,0010041	126,5	0,4366	0,0010040	126,6	0,4365	0,0010040	126,7	0,4365
40	0,0010076	168,2	0,5722	0,0010075	168,2	0,5721	0,0010075	168,3	0,5721	0,0010074	168,4	0,5720
50	0,0010118	209,9	0,7035	0,0010118	210,0	0,7034	0,0010117	210,1	0,7034	0,0010117	210,2	0,7033
60	0,0010168	251,7	0,8309	0,0010168	251,8	0,8308	0,0010167	251,9	0,8307	0,0010167	252,0	0,8307
70	0,0010225	293,6	0,9546	0,0010224	293,6	0,9545	0,0010224	293,7	0,9545	0,0010223	293,8	0,9544
80	0,0010287	335,5	1,0750	0,0010287	335,5	1,0749	0,0010286	335,6	1,0748	0,0010286	335,7	1,0748
90	0,0010356	377,5	1,1922	0,0010356	377,5	1,1921	0,0010355	377,6	1,1921	0,0010355	377,7	1,1920

t	p = 700 кПа t _с = 164,95			p = 800 кПа t _с = 170,41			p = 900 кПа t _с = 175,89			p = 1,00 МПа t _с = 179,89		
	v [*] = 0,2728	i [*] = 2762,7	s [*] = 6,7070	v [*] = 0,2403	i [*] = 2768,3	s [*] = 6,6615	v [*] = 0,2149	i [*] = 2773,0	s [*] = 6,6212	v [*] = 0,1943	i [*] = 2777,1	s [*] = 6,645450
	v	i	s	v	i	s	v	i	s	v	i	s
100	0,0010432	419,5	1,3065	0,0010431	419,6	1,3065	0,0010430	419,7	1,3064	0,0010430	419,8	1,3063
110	0,0010513	461,8	1,4182	0,0010512	461,8	1,4181	0,0010512	461,9	1,4180	0,0010511	462,0	1,4179
120	0,0010600	504,1	1,5274	0,0010600	504,2	1,5273	0,0010599	504,3	1,5272	0,0010599	504,3	1,5271
130	0,0010695	546,7	1,6342	0,0010694	546,7	1,6341	0,0010693	546,8	1,6340	0,0010693	546,9	1,6339
140	0,0010795	589,4	1,7389	0,0010795	589,5	1,7388	0,0010794	589,5	1,7387	0,0010794	589,6	1,7386
150	0,0010904	632,4	1,8417	0,0010903	632,5	1,8416	0,0010902	632,5	1,8415	0,0010902	632,6	1,8414
160	0,0011019	675,6	1,9427	0,0011019	675,7	1,9426	0,0011018	675,7	1,9424	0,0011017	675,8	1,9423
170	0,2768	2775,4	6,7356	0,0011143	719,2	2,0419	0,0011142	719,3	2,0418	0,0011141	719,3	2,0417
180	0,2847	2799,4	6,7892	0,2472	2792,4	6,7154	0,2179	2785,2	6,6481	0,1944	2777,4	6,5857
190	0,2924	2822,6	6,8399	0,2541	2816,5	6,7678	0,2242	2810,1	6,7026	0,2003	2803,5	6,6426
200	0,3000	2845,3	6,8884	0,2609	2839,8	6,8176	0,2304	2834,1	6,7538	0,2060	2828,3	6,6955
210	0,3074	2867,6	6,9350	0,2675	2862,6	6,8653	0,2364	2857,4	6,8027	0,2115	2852,2	6,7455
220	0,3148	2889,5	6,9800	0,2740	2885,0	6,9112	0,2423	2880,3	6,8495	0,2170	2857,6	6,7934
230	0,3220	2911,3	7,0236	0,2805	2907,1	6,9555	0,2482	2902,8	6,8947	0,2223	2898,4	6,8393
240	0,3292	2932,8	7,0659	0,2869	2928,9	6,9985	0,2539	2925,0	6,9383	0,2276	2921,0	6,8837
250	0,3364	2954,1	7,1071	0,2932	2950,5	7,0403	0,2596	2946,9	6,9806	0,2327	2943,2	6,9266
260	0,3434	2975,4	7,1473	0,2995	2972,0	7,0810	0,2653	2968,6	7,0218	0,2379	2965,2	6,9683
270	0,3505	2996,5	7,1866	0,3057	2993,4	7,1206	0,2708	2990,2	7,0619	0,2430	2987,0	7,0088
280	0,3575	3017,5	7,2250	0,3119	3014,6	7,1594	0,2764	3011,7	7,1010	0,2480	3008,7	7,0484
290	0,3645	3038,5	7,2626	0,3180	3035,8	7,1974	0,2819	3033,0	7,1393	0,2530	3030,3	7,0870
300	0,3714	3059,5	7,2995	0,3242	3056,9	7,2345	0,2874	3054,3	7,1768	0,2580	3051,7	7,1247
310	0,3783	3080,4	7,3357	0,3302	3078,0	7,2710	0,2928	3075,5	7,2135	0,2629	3073,1	7,1617
320	0,3852	3101,4	7,3713	0,3363	3099,1	7,3068	0,2983	3096,7	7,2495	0,2678	3094,4	7,1979
330	0,3921	3122,3	7,4063	0,3424	3120,1	7,3420	0,3037	3117,9	7,2849	0,2727	3115,7	7,2335
340	0,3989	3143,2	7,4407	0,3484	3141,1	7,3765	0,3091	3139,0	7,3196	0,2776	3136,9	7,2685
350	0,4058	3164,1	7,4745	0,3544	3162,2	7,4106	0,3145	3160,2	7,3538	0,2825	3158,2	7,3028
360	0,4126	3185,1	7,5079	0,3604	3183,2	7,4441	0,3198	3181,3	7,3875	0,2873	3179,4	7,3366
370	0,4194	3206,1	7,5408	0,3664	3204,2	7,4771	0,3252	3202,4	7,4206	0,2922	3200,6	7,3699
380	0,4262	3227,0	7,5732	0,3724	3225,3	7,5096	0,3305	3223,6	7,4532	0,2970	3221,9	7,4026
390	0,4330	3248,1	7,6051	0,3783	3246,4	7,5416	0,3358	3244,8	7,4854	+ 0,3018	3243,1	7,4349
400	0,4398	3269,1	7,6366	0,3843	3267,6	7,5733	0,3411	3266,0	7,5172	0,3066	3264,4	7,4668
410	0,4465	3290,2	7,6678	0,3902	3288,7	7,6045	0,3464	3287,2	7,5485	0,3114	3285,7	7,4982
420	0,4533	3311,4	7,6985	0,3961	3309,9	7,6353	0,3517	3308,5	7,5794	0,3162	3307,0	7,5292
430	0,4600	3332,6	7,7288	0,4021	3331,2	7,6657	0,3570	3329,8	7,6099	0,3209	3328,4	7,5598
440	0,4668	3353,8	7,7588	0,4080	3352,5	7,6958	0,3623	3351,1	7,6400	0,3257	3349,8	7,5900
450	0,4735	3375,1	7,7884	0,4139	3373,8	7,7255	0,3675	3372,5	7,6698	0,3304	3371,2	7,6198
460	0,4802	3396,4	7,8177	0,4198	3395,2	7,7548	0,3728	3393,9	7,6992	0,3352	3392,7	7,6493
470	0,4869	3417,8	7,8467	0,4257	3416,6	7,7839	0,3780	3415,4	7,7283	0,3399	3414,2	7,6785
480	0,4936	3439,2	7,8753	0,4316	3438,1	7,8126	0,3833	3436,9	7,7571	0,3447	3435,7	7,7073
490	0,5003	3460,7	7,9037	0,4374	3459,6	7,8410	0,3885	3458,5	7,7855	0,3494	3457,3	7,7358

t	p = 700 кПа t _с = 164,95			p = 800 кПа t _с = 170,41			p = 900 кПа t _с = 175,89			p = 1,00 МПа t _с = 179,89		
	v ^o = 0,2728	i ^o = 2762,7	s ^o = 6,7070	v ^o = 0,2403	i ^o = 2768,3	s ^o = 6,6615	v ^o = 0,2149	i ^o = 2773,0	s ^o = 6,6212	v ^o = 0,1943	i ^o = 2777,1	s ^o = 6,45450
	v	i	s	v	i	s	v	i	s	v	i	s
500	0,5070	3482,3	7,9317	0,4433	3481,2	7,8690	0,3938	3480,1	7,8136	0,3541	3479,0	7,7640
510	0,5137	3503,8	7,9595	0,4492	3502,8	7,8969	0,3990	3501,8	7,8415	0,3588	3500,7	7,7919
520	0,5204	3525,5	7,9870	0,4551	3524,5	7,9244	0,4042	3523,5	7,8691	0,3635	3522,5	7,8195
530	0,5271	3547,2	8,0142	0,4609	*3546,2	7,9516	0,4094	3545,3	7,8963	0,3683	3544,3	7,8468
540	0,5338	3569,0	8,0411	0,4668	3568,0	7,9786	0,4147	3567,1	7,9234	0,3730	3566,2	7,8739
550	0,5405	3590,8	8,0678	0,4726	3589,9	8,0053	0,4199	3589,0	7,9501	0,3777	3588,1	7,9007
560	0,5472	3612,7	8,0942	0,4785	3611,8	8,0318	0,4251	3610,9	7,9766	0,3824	3610,1	7,9272
570	0,5538	3634,7	8,1204	0,4843	3633,8	8,0580	0,4303	3632,9	8,0029	0,3870	3632,1	7,9535
580	0,5605	3656,7	8,1464	0,4902	3655,8	8,0840	0,4355	3655,0	8,0289	0,3917	3654,2	7,9795
590	0,5672	3678,8	8,1721	0,4960	3678,0	8,1098	0,4407	3677,1	8,0547	0,3964	3676,3	8,0054
600	0,5738	3700,9	8,1976	0,5019	3700,1	8,1353	0,4459	3699,3	8,0803	0,4011	3698,6	8,0309
610	0,5805	3723,1	8,2229	0,5077	3722,3	8,1606	0,4511	3721,6	8,1056	0,4058	3720,8	8,0563
620	0,5871	3745,4	8,2480	0,5135	3744,6	8,1857	0,4563	3743,9	8,1307	0,4105	3743,2	8,0815
630	0,5938	3767,7	8,2728	0,5194	3767,0	8,2106	0,4615	3766,3	8,1556	0,4151	3765,6	8,1064
640	0,6004	3790,1	8,2975	0,5252	3789,4	8,2353	0,4667	3788,7	8,1803	0,4198	3788,0	8,1311
650	0,6071	3812,6	8,3220	0,5310	3811,9	8,2598	0,4718	3811,2	8,2049	0,4245	3810,5	8,1557
660	0,6137	3835,1	8,3462	0,5368	3834,4	8,2841	0,4770	3833,8	8,2292	0,4292	3833,1	8,1800
670	0,6204	3857,7	8,3703	0,5427	3857,1	8,3082	0,4822	3856,4	8,2533	0,4338	3855,8	8,2041
680	0,6270	3880,4	8,3942	0,5485	3879,7	8,3321	0,4874	3879,1	8,2772	0,4385	3878,5	8,2281
690	0,6337	3903,1	8,4179	0,5543	3902,5	8,3558	0,4926	3901,9	8,3010	0,4432	3901,3	8,2519
700	0,6403	3925,9	8,4415	0,5601	3925,3	8,3794	0,4977	3924,7	8,3246	0,4478	3924,1	8,2755
710	0,6470	3948,7	8,4649	0,5659	3948,2	8,4028	0,5029	3947,6	8,3480	0,4525	3947,0	8,2989
720	0,6536	3971,7	8,4881	0,5717	3971,1	8,4260	0,5081	3970,6	8,3712	0,4572	3970,0	8,3221
730	0,6602	3994,7	8,5111	0,5776	3994,1	8,4490	0,5133	3993,6	8,3943	0,4618	3993,0	8,3452
740	0,6669	4017,7	8,5340	0,5834	4017,2	8,4719	0,5184	4016,7	8,4172	0,4665	4016,1	8,3681
750	0,6735	4040,8	8,5567	0,5892	4040,3	8,4947	0,5236	4039,8	8,4399	0,4711	4039,3	8,3909
760	0,6801	4064,0	8,5792	0,5950	4063,5	8,5172	0,5288	4063,0	8,4625	0,4758	4062,5	8,4135
770	0,6868	4087,3	8,6017	0,6008	4086,8	8,5397	0,5339	4086,3	8,4849	0,4804	4085,8	8,4359
780	0,6934	4110,6	8,6239	0,6066	4110,2	8,5619	0,5391	4109,7	8,5072	0,4851	4109,2	8,4582
790	0,7000	4134,0	8,6460	0,6124	4133,6	8,5840	0,5442	4133,1	8,5293	0,4897	4132,6	8,4804
800	0,7066	4157,5	8,6680	0,6182	4157,0	8,6060	0,5494	4156,6	8,5513	0,4944	4156,1	8,5024
810	0,7133	4181,1	8,6898	0,6240	4180,6	8,6279	0,5546	4180,2	8,5732	0,4990	4179,7	8,5242
820	0,7199	4204,7	8,7115	0,6298	4204,2	8,6496	0,5597	4203,8	8,5949	0,5037	4203,4	8,5460
830	0,7265	4228,3	8,7331	0,6356	4227,9	8,6712	0,5649	4227,5	8,6165	0,5083	4227,1	8,5675
840	0,7332	4252,1	8,7545	0,6414	4251,7	8,6926	0,5701	4251,3	8,6379	0,5130	4250,8	8,5890
850	0,7398	4275,9	8,7758	0,6472	4275,5	8,7139	0,5752	4275,1	8,6592	0,5176	4274,7	8,6103
860	0,7464	4299,8	8,7970	0,6530	4299,4	8,7350	0,5804	4299,0	8,6804	0,5223	4298,6	8,6315
870	0,7530	4323,7	8,8180	0,6588	4323,3	8,7561	0,5855	4322,9	8,7014	0,5269	4322,5	8,6525
880	0,7596	4347,7	8,8389	0,6646	4347,3	8,7770	0,5907	4346,9	8,7224	0,5316	4346,6	8,6735
890	0,7663	4371,8	8,8597	0,6704	4371,4	8,7978	0,5958	4371,0	8,7432	0,5362	4370,6	8,6943
900	0,7729	4395,9	8,8803	0,6762	4395,5	8,8184	0,6010	4395,2	8,7638	0,5408	4394,8	8,7149
910	0,7795	4420,1	8,9009	0,6820	4419,7	8,8390	0,6061	4419,4	8,7844	0,5455	4419,0	8,7355
920	0,7861	4444,3	8,9213	0,6878	4444,0	8,8594	0,6113	4443,7	8,8048	0,5501	4443,3	8,7559
930	0,7927	4468,7	8,9416	0,6936	4468,3	8,8797	0,6165	4468,0	8,8251	0,5548	4467,7	8,7763
940	0,7994	4493,1	8,9618	0,6994	4492,7	8,8999	0,6216	4492,4	8,8453	0,5594	4492,1	8,7965
950	0,8060	4517,5	8,9819	0,7052	4517,2	8,9200	0,6268	4516,9	8,8654	0,5640	4516,5	8,8166
960	0,8126	4542,0	9,0018	0,7110	4541,7	8,9400	0,6319	4541,4	8,8854	0,5687	4541,1	8,8366
970	0,8192	4566,6	9,0217	0,7167	4566,3	8,9598	0,6371	4566,0	8,9053	0,5733	4565,7	8,8564
980	0,8258	4591,3	9,0414	0,7225	4591,0	8,9796	0,6422	4590,7	8,9250	0,5779	4590,4	8,8762
990	0,8324	4616,0	9,0611	0,7283	4615,7	8,9993	0,6474	4615,4	8,9447	0,5826	4615,1	8,8959
1000	0,8390	4640,8	9,0806	0,7341	4640,5	9,0188	0,6525	4640,2	8,9642	0,5872	4639,9	8,9154

t	p = 1,5 MPa t _g = 198,30			p = 2,0 MPa t _g = 212,38			p = 2,5 MPa t _g = 223,96			p = 3,0 MPa t _g = 233,86		
	v ⁻ = 0,1317	i ⁻ = 2791,0	s ⁻ = 6,1431	v ⁻ = 0,09958	i ⁻ = 2798,4	s ⁻ = 6,3392	v ⁻ = 0,07995	i ⁻ = 2802,0	s ⁻ = 6,2560	v ⁻ = 0,06666	i ⁻ = 2803,1	s ⁻ = 6,1858
	v	i	s	v	i	s	v	i	s	v	i	s
0	0,0009994	1,5	-0,0001	0,0009992	2,0	0,0000	0,0009989	2,5	0,0000	0,0009987	3,0	0,0000
10	0,0009996	43,5	0,1510	0,0009994	44,0	0,1509	0,0009992	44,5	0,1509	0,0009989	44,9	0,1508
20	0,0010012	85,3	0,2962	0,0010009	85,8	0,2961	0,0010007	86,3	0,2960	0,0010005	86,7	0,2959
30	0,0010037	127,1	0,4363	0,0010035	127,6	0,4362	0,0010033	128,0	0,4360	0,0010031	128,5	0,4359
40	0,0010072	168,9	0,5719	0,0010070	169,3	0,5717	0,0010068	169,7	0,5715	0,0010066	170,2	0,5713
50	0,0010115	210,6	0,7031	0,0010113	211,0	0,7029	0,0010110	211,5	0,7026	0,0010108	211,9	0,7024
60	0,0010164	252,4	0,8304	0,0010162	252,8	0,8302	0,0010160	253,2	0,8299	0,0010158	253,7	0,8296
70	0,0010221	294,2	0,9541	0,0010219	294,6	0,9538	0,0010216	295,0	0,9535	0,0010214	295,4	0,9532
80	0,0010284	336,1	1,0744	0,0010281	336,5	1,0741	0,0010279	336,9	1,0738	0,0010276	337,3	1,0734
90	0,0010352	378,1	1,1916	0,0010350	378,5	1,1913	0,0010348	378,8	1,1909	0,0010345	379,2	1,1905
100	0,0010427	420,1	1,3059	0,0010425	420,5	1,3055	0,0010422	420,9	1,3051	0,0010420	421,3	1,3048
110	0,0010509	462,4	1,4175	0,0010506	462,7	1,4171	0,0010503	463,1	1,4167	0,0010501	463,4	1,4163
120	0,0010596	504,7	1,5266	0,0010593	505,1	1,5262	0,0010590	505,4	1,5257	0,0010588	505,8	1,5253
130	0,0010690	547,2	1,6334	0,0010687	547,6	1,6329	0,0010684	547,9	1,6325	0,0010681	548,2	1,6320
140	0,0010790	589,9	1,7381	0,0010787	590,3	1,7376	0,0010784	590,6	1,7371	0,0010781	590,9	1,7365
150	0,0010898	632,9	1,8408	0,0010895	633,2	1,8403	0,0010891	633,5	1,8397	0,0010888	633,8	1,8391
160	0,0011013	676,1	1,9417	0,0011010	676,4	1,9411	0,0011006	676,7	1,9405	0,0011003	677,0	1,9399
170	0,0011137	719,6	2,0410	0,0011133	719,9	2,0404	0,0011129	720,1	2,0397	0,0011125	720,4	2,0391
180	0,0011270	763,4	2,1389	0,0011265	763,7	2,1382	0,0011261	763,9	2,1375	0,0011257	764,2	2,1368
190	0,0011412	807,7	2,2354	0,0011408	807,9	2,2347	0,0011403	808,1	2,2339	0,0011398	808,4	2,2332
200	0,1324	2796,0	6,4537	0,0011561	852,6	2,3301	0,0011556	852,8	2,3293	0,0011550	853,0	2,3285
210	0,1366	2823,9	6,5120	0,0011726	897,8	2,4246	0,0011720	897,9	2,4237	0,0011715	898,1	2,4229
220	0,1406	2850,2	6,5658	0,1022	2821,7	6,3868	0,0011899	943,7	2,5175	0,0011893	943,8	2,5165
230	0,1445	2875,5	6,6166	0,1054	2850,2	6,4440	0,08170	2821,9	6,2956	0,0012087	990,2	2,6097
240	0,1483	2900,0	6,6649	0,1085	2877,2	6,4972	0,08444	2852,3	6,3555	0,06823	2824,6	6,2275
250	0,1520	2924,0	6,7111	0,1115	2903,2	6,5474	0,08704	2880,9	6,4106	0,07062	2856,5	6,2893
260	0,1556	2947,5	6,7556	0,1144	2928,5	6,5952	0,08955	2908,2	6,4624	0,07289	2886,4	6,3458
270	0,1592	2970,6	6,7986	0,1172	2953,1	6,6410	0,09198	2934,6	6,5114	0,07506	2914,8	6,3987
280	0,1628	2993,4	6,8402	0,1200	2977,2	6,6850	0,09435	2960,2	6,5581	0,07716	2942,2	6,4485
290	0,1662	3015,9	6,8806	0,1228	3000,9	6,7274	0,09666	2985,1	6,6029	0,07919	2968,6	6,4959
300	0,1697	3038,3	6,9199	0,1255	3024,3	6,7682	0,09893	3009,6	6,6460	0,08118	2994,3	6,5412
310	0,1731	3060,4	6,9582	0,1282	3047,3	6,8084	0,1012	3033,7	6,6876	0,08312	3019,5	6,5847
320	0,1765	3082,5	6,9957	0,1308	3070,2	6,8472	0,1034	3057,4	6,7279	0,08500	3044,2	6,6267
330	0,1799	3104,4	7,0324	0,1334	3092,8	6,8851	0,1055	3080,8	6,7671	0,08689	3068,5	6,6673
340	0,1832	3126,3	7,0683	0,1360	3115,3	6,9221	0,1077	3104,0	6,8052	0,08874	3092,4	6,7066
350	0,1866	3148,0	7,1035	0,1386	3137,6	6,9582	0,1098	3127,0	6,8424	0,09056	3116,1	6,7449
360	0,1899	3169,8	7,1381	0,1412	3159,9	6,9937	0,1119	3149,8	6,8787	0,09235	3139,5	6,7822
370	0,1932	3191,4	7,1721	0,1437	3182,1	7,0284	0,1140	3172,5	6,9142	0,09413	3162,7	6,8186
380	0,1965	3213,1	7,2055	0,1462	3204,2	7,0625	0,1160	3195,1	6,9491	0,09590	3185,8	6,8542
390	0,1998	3234,7	7,2384	0,1487	3226,2	7,0960	0,1181	3217,6	6,9832	0,09764	3208,7	6,8891
400	0,2030	325614	7,2708	0,1512	3248,2	7,1290	0,1201	3240,0	7,0168	0,09938	3231,6	6,9233

t	p = 1,5 МПа ε _s = 198,30			p = 2,0 МПа ε _s = 212,38			p = 2,5 МПа ε _s = 223,96			p = 3,0 МПа ε _s = 233,86		
	v [*] = 0,1317	i [*] = 2791,0	s [*] = 6,1431	v [*] = 0,09958	i [*] = 2798,4	s [*] = 6,3392	v [*] = 0,07995	i [*] = 2802,0	s [*] = 6,2560	v [*] = 0,06666	i [*] = 2803,1	s [*] = 6,1858
	v	i	s	v	i	s	v	i	s	v	i	s
410	0,2063	3278,0	7,3027	0,1537	3270,2	7,1614	0,1221	3262,3	7,0497	0,1011	3254,3	6,9568
420	0,2095	3299,6	7,3341	0,1562	3292,2	7,1933	0,1242	3284,6	7,0822	0,1028	3277,0	6,9897
430	0,2127	3321,3	7,3651	0,1586	3314,1	7,2248	0,1262	3306,9	7,1141	0,1045	3299,6	7,0221
440	0,2160	3343,0	7,3957	0,1611	3336,1	7,2558	0,1282	3329,2	7,1455	0,1062	3322,1	7,0540
450	0,2192	3364,7	7,4259	0,1635	3358,1	7,2863	0,1302	3351,4	7,1765	0,1079	3344,7	7,0853
460	0,2224	3386,4	7,4558	0,1660	3380,0	7,3165	0,1321	3373,6	7,2070	0,1096	3367,2	7,1162
470	0,2256	3408,1	7,4852	0,1684	3402,0	7,3463	0,1341	3395,8	7,2371	0,1112	3389,6	7,1467
480	0,2288	3429,9	7,5143	0,1708	3424,0	7,3757	0,1361	3418,1	7,2668	0,1129	3412,1	7,1767
490	0,2320	3451,7	7,5431	0,1733	3446,0	7,4048	0,1380	3440,3	7,2962	0,1145	3434,6	7,2063
500	0,2352	3473,6	7,5716	0,1757	3468,1	7,4335	0,1400	3462,6	7,3251	0,1162	3457,0	7,2356
510	0,2383	3495,5	7,5997	0,1781	3490,2	7,4619	0,1419	3484,9	7,3538	0,1178	3479,5	7,2645
520	0,2415	3517,4	7,6275	0,1805	3512,3	7,4899	0,1439	3507,2	7,3821	0,1195	3502,0	7,2930
530	0,2447	3539,4	7,6551	0,1829	3534,5	7,5177	0,1458	3529,5	7,4100	0,1211	3524,5	7,3212
540	0,2479	3561,4	7,6823	0,1853	3556,6	7,5451	0,1478	3551,9	7,4377	0,1227	3547,0	7,3491
550	0,2510	3583,5	7,7093	0,1877	3578,9	7,5723	0,1497	3574,2	7,4651	0,1244	3569,6	7,3767
560	0,2542	3605,6	7,7360	0,1901	3601,2	7,5992	0,1516	3596,7	7,4922	0,1260	3592,2	7,4039
570	0,2573	3627,8	7,7625	0,1925	3623,5	7,6258	0,1536	3619,1	7,5190	0,1276	3614,8	7,4309
580	0,2605	3650,0	7,7887	0,1949	3645,8	7,6522	0,1555	3641,6	7,5455	0,1292	3637,4	7,4576
590	0,2636	3672,3	7,8147	0,1972	3668,2	7,6783	0,1574	3664,2	7,5718	0,1308	3660,1	7,4840
600	0,2668	3694,6	7,8404	0,1996	3690,7	7,7042	0,1593	3686,8	7,5978	0,1324	3682,8	7,5102
610	0,2699	3717,0	7,8659	0,2020	3713,2	7,7298	0,1612	3709,4	7,6235	0,1341	3705,6	7,5361
620	0,2731	3739,5	7,8912	0,2044	3735,8	7,7552	0,1631	3732,1	7,6491	0,1357	3728,4	7,5617
630	0,2762	3762,0	7,9162	0,2067	3758,4	7,7804	0,1650	3754,8	7,6744	0,1373	3751,2	7,5872
640	0,2793	3784,6	7,9411	0,2091	3781,1	7,8054	0,1670	3777,6	7,6995	0,1389	3774,1	7,6124
650	0,2825	3807,2	7,9657	0,2115	3803,8	7,8301	0,1689	3800,4	7,7243	0,1405	3797,0	7,6373
660	0,2856	3829,9	7,9902	0,2138	3826,6	7,8547	0,1708	3823,3	7,7490	0,1420	3820,0	7,6621
670	0,2887	3852,6	8,0144	0,2162	3849,4	7,8790	0,1727	3846,2	7,7734	0,1436	3843,0	7,6866
680	0,2919	3875,4	8,0384	0,2185	3872,3	7,9032	0,1746	3869,2	7,7976	0,1452	3866,1	7,7109
690	0,2950	3898,3	8,0623	0,2209	3895,2	7,9271	0,1765	3892,2	7,8217	0,1468	3889,2	7,7351
700	0,2981	3921,2	8,0860	0,2233	3918,2	7,9509	0,1783	3915,3	7,8455	0,1484	3912,3	7,7590
710	0,3012	3944,2	8,1095	0,2256	3941,3	7,9744	0,1802	3938,4	7,8692	0,1500	3935,6	7,7828
720	0,3044	3967,2	8,1328	0,2280	3964,4	7,9978	0,1821	3961,6	7,8927	0,1516	3958,8	7,8063
730	0,3075	3990,3	8,1560	0,2303	3987,6	8,0211	0,1840	3984,9	7,9160	0,1532	3982,2	7,8297
740	0,3106	4013,5	8,1789	0,2327	4010,9	8,0441	0,1859	4008,2	7,9391	0,1547	4005,6	7,8529
750	0,3137	4036,7	8,2018	0,2350	4034,2	8,0670	0,1878	4031,6	7,9620	0,1563	4029,0	7,8759
760	0,3168	4060,0	8,2244	0,2374	4057,5	8,0897	0,1897	4055,0	7,9848	0,1579	4052,5	7,8987
770	0,3199	4083,4	8,2469	0,2397	4080,9	8,1123	0,1916	4078,5	8,0074	0,1595	4076,0	7,9214
780	0,3231	4106,8	8,2693	0,2421	4104,4	8,1347	0,1934	4102,0	8,0299	0,1610	4099,6	7,9440
790	0,3262	4130,3	8,2915	0,2444	4128,0	8,1570	0,1953	4125,6	8,0522	0,1626	4123,3	7,9663
800	0,3293	4153,9	8,3135	0,2467	4151,6	8,1791	0,1972	4149,3	8,0744	0,1642	4147,0	7,9885
810	0,3324	4177,5	8,3355	0,2491	4175,3	8,2010	0,1991	4173,1	8,0964	0,1658	4170,8	8,0106
820	0,3355	4201,2	8,3572	0,2514	4199,0	8,2228	0,2010	4196,8	8,1182	0,1673	4194,7	8,0325
830	0,3386	4224,9	8,3789	0,2538	4222,8	8,2445	0,2028	4220,7	8,1400	0,1689	4218,6	8,0543
840	0,3417	4248,8	8,4003	0,2561	4246,7	8,2661	0,2047	4244,6	8,1615	0,1705	4242,5	8,0759
850	0,3448	4272,6	8,4217	0,2584	4270,6	8,2874	0,2066	4268,6	8,1830	0,1720	4266,5	8,0974
860	0,3479	4296,6	8,4429	0,2608	4294,6	8,3087	0,2085	4292,6	8,2043	0,1736	4290,6	8,1187
870	0,3510	4320,6	8,4640	0,2631	4318,6	8,3298	0,2104	4316,7	8,2255	0,1752	4314,8	8,1399
880	0,3541	4344,7	8,4850	0,2654	4342,8	8,3508	0,2122	4340,9	8,2465	0,1767	4339,0	8,1610
890	0,3573	4368,8	8,5058	0,2678	4366,9	8,3717	0,2141	4365,1	8,2674	0,1783	4363,2	8,1819

t	$p = 1,5 \text{ MPa}$ $t_s = 198,30$			$p = 2,0 \text{ MPa}$ $t_s = 212,38$			$p = 2,5 \text{ MPa}$ $t_s = 223,96$			$p = 3,0 \text{ MPa}$ $t_s = 233,86$		
	v^- 0,1317	i^- 2791,0	s^- 6,1431	v^- 0,09958	i^- 2798,4	s^- 6,3392	v^- 0,07995	i^- 2802,0	s^- 6,2560	v^- 0,06666	i^- 2803,1	s^- 6,1858
	v	i	s	v	i	s	v	i	s	v	i	s
900	0,3604	4393,0	8,5265	0,2701	4391,2	8,3925	0,2160	4389,3	8,2882	0,1799	4387,5	8,2027
910	0,3635	4417,2	8,5471	0,2724	4415,5	8,4131	0,2178	4413,7	8,3088	0,1814	4411,9	8,2234
920	0,3666	4441,6	8,5676	0,2748	4439,8	8,4336	0,2197	4438,1	8,3294	0,1830	4436,3	8,2440
930	0,3697	4466,0	8,5879	0,2771	4464,3	8,4540	0,2216	4462,6	8,3498	0,1846	4460,8	8,2645
940	0,3728	4490,4	8,6082	0,2794	4488,7	8,4742	0,2235	4487,1	8,3701	0,1861	4485,4	8,2848
950	0,3759	4514,9	8,6283	0,2818	4513,3	8,4944	0,2253	4511,7	8,3903	0,1877	4510,0	8,3050
960	0,3790	4539,5	8,6483	0,2841	4537,9	8,5144	0,2272	4536,3	8,4103	0,1892	4534,7	8,3251
970	0,3821	4564,1	8,6682	0,2864	4562,6	8,5344	0,2291	4561,0	8,4303	0,1908	4559,5	8,3451
980	0,3852	4588,8	8,6880	0,2888	4587,3	8,5542	0,2309	4585,8	8,4501	0,1924	4584,3	8,3649
990	0,3883	4613,6	8,7077	0,2911	4612,1	8,5739	0,2328	4610,6	8,4699	0,1939	4609,1	8,3847
1000	0,3914	4638,4	8,7273	0,2934	4637,0	8,5935	0,2347	4635,5	8,4895	0,1955	4634,0	8,4044

3-jadval (davomi)

t	$p = 3,5 \text{ MPa}$ $t_s = 242,56$			$p = 4,0 \text{ MPa}$ $t_s = 250,36$			$p = 4,5 \text{ MPa}$ $t_s = 263,44$			$p = 5,0 \text{ MPa}$ $t_s = 263,94$		
	v^- 0,05706	i^- 2802,7	s^- 6,1245	v^- 0,04978	i^- 2800,9	s^- 6,0697	v^- 0,04406	i^- 2798,0	s^- 6,0198	v^- 0,03945	i^- 2794,2	s^- 5,9737
	v	i	s	v	i	s	v	i	s	v	i	s
0	0,0009984	3,5	0,0001	0,0009982	4,0	0,0001	0,0009979	4,5	0,0001	0,0009977	5,0	0,0001
10	0,0009987	45,4	0,1508	0,0009984	45,9	0,1507	0,0009982	46,4	0,1507	0,0009980	46,9	0,1506
20	0,0010002	87,2	0,2958	0,0010000	87,7	0,2957	0,0009998	88,1	0,2956	0,0009996	88,6	0,2955
30	0,0010028	128,9	0,4357	0,0010026	129,4	0,4356	0,0010024	129,8	0,4354	0,0010022	130,3	0,4353
40	0,0010063	170,6	0,5711	0,0010061	171,1	0,5709	0,0010059	171,5	0,5707	0,0010057	172,0	0,5705
50	0,0010106	212,3	0,7022	0,0010104	212,8	0,7020	0,0010102	213,2	0,7017	0,0010099	213,6	0,7015
60	0,0010156	254,1	0,8294	0,0010153	254,5	0,8291	0,0010151	254,9	0,8288	0,0010149	255,3	0,8286
70	0,0010212	295,9	0,9529	0,0010209	296,3	0,9526	0,0010207	296,7	0,9523	0,0010205	297,1	0,9520
80	0,0010274	337,7	1,0731	0,0010272	338,1	1,0728	0,0010269	338,5	1,0725	0,0010267	338,9	1,0721
90	0,0010343	379,6	1,1902	0,0010340	380,0	1,1898	0,0010338	380,4	1,1895	0,0010335	380,8	1,1891
100	0,0010417	421,7	1,3044	0,0010415	422,0	1,3040	0,0010412	422,4	1,3036	0,0010410	422,8	1,3032
110	0,0010498	463,8	1,4158	0,0010495	464,2	1,4154	0,0010493	464,5	1,4150	0,0010490	464,9	1,4146
120	0,0010585	506,1	1,5248	0,0010582	506,5	1,5244	0,0010579	506,8	1,5239	0,0010577	507,2	1,5235
130	0,0010678	548,6	1,6315	0,0010675	548,9	1,6310	0,0010672	549,3	1,6305	0,0010669	549,6	1,6301
140	0,0010778	591,2	1,7360	0,0010775	591,6	1,7355	0,0010772	591,9	1,7350	0,0010769	592,2	1,7345
150	0,0010885	634,1	1,8386	0,0010881	634,4	1,8380	0,0010878	634,7	1,8375	0,0010875	635,1	1,8369
160	0,0010999	677,3	1,9393	0,0010996	677,6	1,9388	0,0010992	677,8	1,9382	0,0010988	678,1	1,9376
170	0,0011122	720,7	2,0385	0,0011118	721,0	2,0378	0,0011114	721,2	2,0372	0,0011110	721,5	2,0366
180	0,0011253	764,5	2,1361	0,0011249	764,7	2,1354	0,0011244	765,0	2,1348	0,0011240	765,2	2,1341
190	0,0011394	808,6	2,2325	0,0011389	808,8	2,2317	0,0011385	809,1	2,2310	0,0011380	809,3	2,2303
200	0,0011545	853,2	2,3277	0,0011540	853,4	2,3269	0,0011535	853,6	2,3261	0,0011530	853,8	2,3254
210	0,0011709	898,3	2,4220	0,0011704	898,5	2,4212	0,0011698	898,6	2,4203	0,0011693	898,8	2,4195
220	0,0011887	944,0	2,5156	0,0011881	944,1	2,5147	0,0011874	944,2	2,5138	0,0011868	944,4	2,5129
230	0,0012080	990,3	2,6087	0,0012073	990,4	2,6077	0,0012066	990,5	2,6067	0,0012059	990,6	2,6057
240	0,0012292	1037,5	2,7016	0,0012284	1037,6	2,7005	0,0012276	1037,6	2,6994	0,0012268	1037,7	2,6983
250	0,05876	2829,7	6,1765	0,0012517	1085,7	2,7933	0,0012508	1085,7	2,7921	0,0012499	1085,7	2,7909
260	0,06088	2862,9	6,2393	0,05178	2837,2	6,1384	0,04457	2808,6	6,0397	0,0012755	1134,8	2,8839

t	p = 3,5 MPa t _g = 242,56			p = 4,0 MPa t _g = 250,36			p = 4,5 MPa t _g = 257,44			p = 5,0 MPa t _g = 263,94		
	v ^o = 0,05706	i ^o = 2802,7	s ^o = 6,1245	v ^o = 0,04978	i ^o = 2800,9	s ^o = 6,0697	v ^o = 0,04406	i ^o = 2798,0	s ^o = 6,0198	v ^o = 0,03945	i ^o = 2794,2	s ^o = 5,9737
	v	i	s	v	i	s	v	i	s	v	i	s
270	0,06289	2893,8	6,2967	0,05369	2871,2	6,2016	0,04645	2846,7	6,1106	0,04057	2819,8	6,0211
280	0,06481	2923,1	6,3502	0,05549	2902,9	6,2594	0,04819	2881,3	6,1737	0,04227	2858,1	6,0909
290	0,06666	2951,2	6,4006	0,05721	2932,9	6,3132	0,04982	2913,5	6,2315	0,04386	2893,0	6,1535
300	0,06845	2978,4	6,4484	0,05887	2961,7	6,3638	0,05138	2944,1	6,2852	0,04535	2925,6	6,2109
310	0,07019	3004,8	6,4940	0,06047	2989,4	6,4118	0,05287	2973,3	6,3358	0,04677	2956,6	6,2645
320	0,07189	3030,5	6,5377	0,06202	3016,3	6,4575	0,05432	3001,5	6,3837	0,04813	2986,2	6,3148
330	0,07356	3055,7	6,5799	0,06354	3042,5	6,5014	0,05572	3028,8	6,4294	0,04945	3014,7	6,3625
340	0,07519	3080,5	6,6206	0,06502	3068,1	6,5435	0,05709	3055,5	6,4732	0,05073	3042,4	6,4080
350	0,07680	3104,8	6,6601	0,06647	3093,3	6,5843	0,05842	3081,5	6,5153	0,05197	3069,3	6,4515
360	0,07839	3128,9	6,6984	0,06790	3118,1	6,6237	0,05974	3107,0	6,5559	0,05319	3095,6	6,4934
370	0,07996	3152,7	6,7357	0,06931	3142,5	6,6620	0,06102	3132,1	6,5953	0,05438	3121,4	6,5339
380	0,08150	3176,4	6,7721	0,07070	3166,7	6,6993	0,06229	3156,9	6,6335	0,05555	3146,8	6,5731
390	0,08304	3199,8	6,8077	0,07207	3190,6	6,7357	0,06354	3181,3	6,6706	0,05670	3171,9	6,6111
400	0,08456	3223,0	6,8426	0,07343	3214,4	6,7712	0,06477	3205,6	6,7069	0,05784	3196,6	6,6481
410	0,08606	3246,2	6,8767	0,07478	3237,9	6,8059	0,06599	3229,6	6,7423	0,05896	3221,1	6,6842
420	0,08755	3269,2	6,9102	0,07611	3261,4	6,8400	0,06720	3253,4	6,7769	0,06007	3245,3	6,7194
430	0,08904	3292,2	6,9430	0,07743	3284,7	6,8734	0,06840	3277,1	6,8108	0,06116	3269,4	6,7539
440	0,09051	3315,0	6,9753	0,07874	3307,9	6,9061	0,06958	3300,6	6,8441	0,06225	3293,3	6,7877
450	0,09198	3337,9	7,0071	0,08004	3331,0	6,9383	0,07076	3324,0	6,8767	0,06332	3317,0	6,8208
460	0,09343	3360,6	7,0384	0,08134	3354,0	6,9700	0,07192	3347,4	6,9088	0,06439	3340,7	6,8532
470	0,09488	3383,4	7,0692	0,08262	3377,1	7,0012	0,07308	3370,7	6,9403	0,06545	3364,2	6,8851
480	0,09633	3406,1	7,0995	0,08390	3400,0	7,0318	0,07424	3393,9	6,9713	0,06650	3387,7	6,9165
490	0,09776	3428,8	7,1295	0,08517	3422,9	7,0621	0,07538	3417,1	7,0019	0,06754	3411,1	6,9474
500	0,09919	3451,5	7,1590	0,08644	3445,8	7,0919	0,07652	3440,2	7,0320	0,06858	3434,5	6,9778
510	0,10062	3474,1	7,1882	0,08770	3468,7	7,1213	0,07765	3463,3	7,0617	0,06962	3457,8	7,0078
520	0,10204	3496,8	7,2169	0,08896	3491,6	7,1503	0,07878	3486,3	7,0910	0,07064	3481,1	7,0373
530	0,1034	3519,5	7,2454	0,09021	3514,5	7,1790	0,07991	3509,4	7,1199	0,07166	3504,3	7,0664
540	0,1049	3542,2	7,2734	0,09146	3537,3	7,2073	0,08103	3532,5	7,1484	0,07268	3527,5	7,0952
550	0,1063	3564,9	7,3012	0,09270	3560,2	7,2353	0,08214	3555,5	7,1765	0,07369	3550,8	7,1235
560	0,1077	3587,6	7,3287	0,09394	3583,1	7,2629	0,08325	3578,5	7,2044	0,07470	3574,0	7,1516
570	0,1091	3610,4	7,3558	0,09517	3606,0	7,2902	0,08436	3601,6	7,2319	0,07571	3597,2	7,1793
580	0,1105	3633,2	7,3827	0,09640	3628,9	7,3172	0,08546	3624,7	7,2591	0,07671	3620,4	7,2066
590	0,1119	3656,0	7,4092	0,09763	3651,9	7,3440	0,08656	3647,7	7,2860	0,07771	3643,6	7,2337
600	0,1132	3678,8	7,4356	0,09886	3674,8	7,3704	0,08766	3670,8	7,3126	0,07870	3666,8	7,2604
610	0,1146	3701,7	7,4616	0,10008	3697,8	7,3966	0,08876	3694,0	7,3389	0,07969	3690,1	7,2869
620	0,1160	3724,6	7,4874	0,10130	3720,9	7,4226	0,08985	3717,1	7,3650	0,08068	3713,3	7,3131
630	0,1174	3747,6	7,5129	0,1025	3743,9	7,4482	0,09094	3740,3	7,3908	0,08167	3736,6	7,3390
640	0,1188	3770,5	7,5383	0,1037	3767,0	7,4737	0,09202	3763,5	7,4163	0,08265	3759,9	7,3647
650	0,1202	3793,6	7,5633	0,1049	3790,2	7,4989	0,09311	3786,7	7,4416	0,08364	3783,3	7,3901
660	0,1215	3816,6	7,5882	0,1062	3813,3	7,5238	0,09419	3810,0	7,4667	0,08462	3806,6	7,4153
670	0,1229	3839,8	7,6128	0,1074	3836,5	7,5486	0,09527	3833,3	7,4915	0,08559	3830,0	7,4402
680	0,1243	3862,9	7,6373	0,1086	3859,8	7,5731	0,09635	3856,6	7,5162	0,08657	3853,5	7,4650
690	0,1256	3886,1	7,6615	0,1098	3883,1	7,5974	0,09742	3880,0	7,5406	0,08754	3876,9	7,4894
700	0,1270	3909,4	7,6855	0,1110	3906,4	7,6215	0,09850	3903,4	7,5647	0,08851	3900,5	7,5137
710	0,1284	3932,7	7,7093	0,1122	3929,8	7,6454	0,09957	3926,9	7,5887	0,08948	3924,0	7,5378
720	0,1297	3956,0	7,7329	0,1134	3953,2	7,6691	0,10064	3950,4	7,6125	0,09045	3947,6	7,5617
730	0,1311	3979,4	7,7564	0,1146	3976,7	7,6926	0,10171	3974,0	7,6361	0,09142	3971,2	7,5853
740	0,1325	4002,9	7,7797	0,1158	4000,2	7,7160	0,1028	3997,6	7,6595	0,09239	3994,9	7,6088

t	p = 3,5 MPa t _g = 242,56			p = 4,0 MPa t _g = 250,36			p = 4,5 MPa t _g = 257,44			p = 5,0 MPa t _g = 263,94		
	v ⁻ = 0,05706	i ⁻ = 2802,7	s ⁻ = 6,1245	v ⁻ = 0,04978	i ⁻ = 2800,9	s ⁻ = 6,0697	v ⁻ = 0,04406	i ⁻ = 2798,0	s ⁻ = 6,0198	v ⁻ = 0,03945	i ⁻ = 2794,2	s ⁻ = 5,9737
	v	i	s	v	i	s	v	i	s	v	i	s
750	0,1338	4026,4	7,8027	0,1170	4023,8	7,7391	0,1038	4021,2	7,6827	0,09335	4018,6	7,6321
760	0,1352	4050,0	7,8257	0,1182	4047,4	7,7621	0,1049	4044,9	7,7058	0,09431	4042,4	7,6552
770	0,1365	4073,6	7,8484	0,1194	4071,1	7,7849	0,1060	4068,6	7,7287	0,09527	4066,2	7,6781
780	0,1379	4097,2	7,8710	0,1205	4094,8	7,8075	0,1070	4092,4	7,7514	0,09623	4090,0	7,7009
790	0,1392	4121,0	7,8934	0,1217	4118,6	7,8300	0,1081	4116,3	7,7739	0,09719	4113,9	7,7235
800	0,1406	4144,7	7,9157	0,1229	4142,5	7,8523	0,1092	4140,2	7,7963	0,09815	4137,9	7,7459
810	0,1420	4168,6	7,9378	0,1241	4166,4	7,8745	0,1102	4164,1	7,8185	0,09911	4161,9	7,7682
820	0,1433	4192,5	7,9597	0,1253	4190,3	7,8965	0,1113	4188,1	7,8405	0,10007	4185,9	7,7903
830	0,1447	4216,4	7,9815	0,1265	4214,3	7,9183	0,1123	4212,2	7,8624	0,10102	4210,0	7,8122
840	0,1460	4240,4	8,0032	0,1277	4238,4	7,9401	0,1134	4236,3	7,8842	0,10200	4234,2	7,8340
850	0,1474	4264,5	8,0247	0,1288	4262,5	7,9616	0,1144	4260,4	7,9058	0,10299	4258,4	7,8557
860	0,1487	4288,6	8,0461	0,1300	4286,6	7,9830	0,1155	4284,6	7,9272	0,10399	4282,6	7,8772
870	0,1500	4312,8	8,0674	0,1312	4310,9	8,0043	0,1166	4308,9	7,9486	0,10488	4307,0	7,8985
880	0,1514	4337,1	8,0885	0,1324	4335,1	8,0255	0,1176	4333,2	7,9697	0,1058	4331,3	7,9197
890	0,1528	4361,3	8,1095	0,1336	4359,5	8,0465	0,1187	4357,6	7,9908	0,10677	4355,8	7,9408
900	0,1541	4385,7	8,1303	0,1348	4383,9	8,0674	0,1197	4382,1	8,0117	0,10777	4380,2	7,9618
910	0,1554	4410,1	8,1510	0,1359	4408,3	8,0881	0,1208	4406,6	8,0325	0,10866	4404,8	7,9826
920	0,1568	4434,6	8,1716	0,1371	4432,9	8,1088	0,1218	4431,1	8,0532	0,10956	4429,4	8,0033
930	0,1581	4459,1	8,1921	0,1383	4457,4	8,1293	0,1229	4455,7	8,0737	0,1105	4454,0	8,0239
940	0,1595	4483,7	8,2125	0,1395	4482,1	8,1497	0,1239	4480,4	8,0941	0,1115	4478,7	8,0444
950	0,1608	4508,4	8,2327	0,1406	4506,8	8,1699	0,1250	4505,1	8,1144	0,1124	4503,5	8,0647
960	0,1622	4533,1	8,2528	0,1418	4531,5	8,1901	0,1260	4529,9	8,1346	0,1134	4528,3	8,0849
970	0,1635	4557,9	8,2729	0,1430	4556,3	8,2101	0,1271	4554,8	8,1547	0,1143	4553,2	8,1050
980	0,1648	4582,7	8,2927	0,1442	4581,2	8,2301	0,1281	4579,7	8,1747	0,1152	4578,1	8,1250
990	0,1661	4607,6	8,3125	0,1454	4606,1	8,2499	0,1292	4604,6	8,1945	0,1162	4603,1	8,1448
1000	0,1675	4632,6	8,3322	0,1465	4631,1	8,2696	0,1302	4629,7	8,2142	0,1171	4628,2	8,1646

3-jadval (davomi)

t	p = 5,5 MPa t _g = 269,97			p = 6,0 MPa t _g = 275,59			p = 6,5 MPa t _g = 280,83			p = 7,0 MPa t _g = 285,83		
	v ⁻ = 0,03564	i ⁻ = 2789,7	s ⁻ = 5,9307	v ⁻ = 0,03245	i ⁻ = 2784,6	s ⁻ = 5,8901	v ⁻ = 0,02973	i ⁻ = 2778,8	s ⁻ = 5,8515	v ⁻ = 0,02738	i ⁻ = 2772,6	s ⁻ = 5,8146
	v	i	s	v	i	s	v	i	s	v	i	s
0	0,0009974	5,5	0,0002	0,0009972	6,0	0,0002	0,0009969	6,5	0,0002	0,0009967	7,1	0,0002
10	0,0009977	47,4	0,1506	0,0009975	47,9	0,1505	0,0009973	48,3	0,1505	0,0009970	48,8	0,1504
20	0,0009993	89,1	0,2953	0,0009991	89,5	0,2952	0,0009989	90,0	0,2951	0,0009987	90,5	0,2950
30	0,0010020	130,7	0,4351	0,0010017	131,2	0,4350	0,0010015	131,7	0,4348	0,0010013	132,1	0,4346
40	0,0010055	172,4	0,5703	0,0010052	172,8	0,5701	0,0010050	173,3	0,5699	0,0010048	173,7	0,5697
50	0,0010097	214,1	0,7013	0,0010095	214,5	0,7010	0,0010093	214,9	0,7008	0,0010091	215,4	0,7006
60	0,0010147	255,8	0,8283	0,0010144	256,2	0,8280	0,0010142	256,6	0,8278	0,0010140	257,0	0,8275
70	0,0010203	297,5	0,9517	0,0010200	297,9	0,9514	0,0010198	298,3	0,9512	0,0010196	298,7	0,9509
80	0,0010265	339,3	1,0718	0,0010262	339,7	1,0715	0,0010260	340,1	1,0712	0,0010258	340,5	1,0708
90	0,0010333	381,2	1,1888	0,0010331	381,6	1,1884	0,0010328	381,9	1,1881	0,0010326	382,3	1,1877
100	0,0010407	423,2	1,3028	0,0010405	423,5	1,3024	0,0010402	423,9	1,3020	0,0010400	424,3	1,3017
110	0,0010487	465,3	1,4142	0,0010485	465,6	1,4138	0,0010482	466,0	1,4133	0,0010480	466,4	1,4129
120	0,0010574	507,5	1,5230	0,0010571	507,9	1,5226	0,0010568	508,2	1,5221	0,0010566	508,6	1,5217
130	0,0010666	549,9	1,6296	0,0010663	550,3	1,6291	0,0010661	550,6	1,6286	0,0010658	551,0	1,6281
140	0,0010765	592,5	1,7340	0,0010762	592,9	1,7335	0,0010759	593,2	1,7329	0,0010756	593,5	1,7324

t	p = 5,5 MPa t _s = 269,97			p = 6,0 MPa t _s = 275,59			p = 6,5 MPa t _s = 280,83			p = 7,0 MPa t _s = 285,83		
	v ⁻ 0,03564	i ⁻ 2789,7	s ⁻ 5,9307	v ⁻ 0,03245	i ⁻ 2784,6	s ⁻ 5,8901	v ⁻ 0,02973	i ⁻ 2778,8	s ⁻ 5,8515	v ⁻ 0,02738	i ⁻ 2772,6	s ⁻ 5,8146
	v	i	s	v	i	s	v	i	s	v	i	s
150	0,0010872	635,4	1,8364	0,0010868	635,7	1,8358	0,0010865	636,0	1,8353	0,0010862	636,3	1,8347
160	0,0010985	678,4	1,9370	0,0010981	678,7	1,9364	0,0010978	679,0	1,9358	0,0010974	679,3	1,9352
170	0,0011106	721,8	2,0359	0,0011102	722,1	2,0353	0,0011099	722,4	2,0347	0,0011095	722,6	2,0341
180	0,0011236	765,5	2,1334	0,0011232	765,7	2,1327	0,0011228	766,0	2,1321	0,0011224	766,2	2,1314
190	0,0011376	809,5	2,2296	0,0011371	809,8	2,2289	0,0011367	810,0	2,2281	0,0011362	810,2	2,2274
200	0,0011525	854,0	2,3246	0,0011521	854,2	2,3238	0,0011516	854,4	2,3230	0,0011511	854,6	2,3223
210	0,0011687	899,0	2,4186	0,0011682	899,2	2,4178	0,0011676	899,3	2,4170	0,0011671	899,5	2,4161
220	0,0011862	944,5	2,5119	0,0011856	944,7	2,5110	0,0011850	944,8	2,5101	0,0011844	945,0	2,5092
230	0,0012052	990,7	2,6047	0,0012046	990,8	2,6037	0,0012039	990,9	2,6027	0,0012032	991,1	2,6018
240	0,0012261	1037,7	2,6972	0,0012253	1037,8	2,6961	0,0012245	1037,8	2,6950	0,0012237	1037,9	2,6939
250	0,0012490	1085,7	2,7897	0,0012481	1085,7	2,7885	0,0012472	1085,6	2,7873	0,0012463	1085,6	2,7861
260	0,0012744	1134,7	2,8825	0,0012734	1134,6	2,8812	0,0012723	1134,5	2,8799	0,0012713	1134,5	2,8785
270	0,03565	2789,9	5,9309	0,0013018	1184,9	2,9747	0,0013005	1184,8	2,9732	0,0012993	1184,6	2,9717
280	0,03737	2832,9	6,0094	0,03320	2805,2	5,9276	0,0013326	1236,6	3,0678	0,0013311	1236,3	3,0661
290	0,03893	2871,1	6,0779	0,03476	2847,5	6,0033	0,03118	2822,0	5,9287	0,02804	2794,0	5,8528
300	0,04037	2906,2	6,1396	0,03619	2885,5	6,0702	0,03261	2863,5	6,0018	0,02949	2839,8	5,9335
310	0,04174	2939,0	6,1965	0,03752	2920,6	6,1309	0,03392	2901,1	6,0670	0,03080	2880,6	6,0040
320	0,04304	2970,2	6,2495	0,03878	2953,5	6,1870	0,03515	2936,1	6,1265	0,03201	2917,9	6,0674
330	0,04430	3000,1	6,2994	0,03998	2984,9	6,2393	0,03632	2969,1	6,1816	0,03315	2952,6	6,1255
340	0,04550	3028,9	6,3468	0,04114	3014,9	6,2887	0,03743	3000,5	6,2332	0,03423	2985,5	6,1796
350	0,04668	3056,8	6,3919	0,04225	3043,9	6,3356	0,03850	3030,6	6,2819	0,03527	3016,8	6,2303
360	0,04782	3083,9	6,4352	0,04334	3072,0	6,3803	0,03953	3059,6	6,3282	0,03626	3047,0	6,2783
370	0,04894	3110,5	6,4768	0,04439	3099,3	6,4232	0,04054	3087,9	6,3724	0,03722	3076,1	6,3240
380	0,05003	3136,6	6,5170	0,04542	3126,1	6,4645	0,04151	3115,4	6,4149	0,03816	3104,4	6,3677
390	0,05110	3162,2	6,5560	0,04643	3152,4	6,5044	0,04247	3142,3	6,4558	0,03907	3132,1	6,4096
400	0,05216	3187,5	6,5938	0,04742	3178,2	6,5431	0,04341	3168,7	6,4953	0,03996	3159,1	6,4501
410	0,05320	3212,4	6,6306	0,04840	3203,6	6,5806	0,04433	3194,7	6,5336	0,04084	3185,6	6,4892
420	0,05423	3237,1	6,6665	0,04936	3228,8	6,6171	0,04523	3220,3	6,5709	0,04169	3211,8	6,5272
430	0,05524	3261,6	6,7015	0,05031	3253,7	6,6528	0,04613	3245,7	6,6071	0,04254	3237,5	6,5641
440	0,05625	3285,8	6,7358	0,05124	3278,3	6,6876	0,04700	3270,7	6,6425	0,04337	3263,0	6,6000
450	0,05724	3309,9	6,7693	0,05217	3302,8	6,7216	0,04787	3295,5	6,6771	0,04419	3288,2	6,6351
460	0,05823	3333,9	6,8022	0,05308	3327,0	6,7550	0,04873	3320,1	6,7109	0,04500	3313,1	6,6694
470	0,05920	3357,7	6,8345	0,05399	3351,2	6,7877	0,04958	3344,6	6,7440	0,04580	3337,9	6,7029
480	0,06017	3381,5	6,8663	0,05489	3375,2	6,8198	0,05043	3368,9	6,7765	0,04659	3362,5	6,7358
490	0,06113	3405,1	6,8975	0,05579	3399,1	6,8513	0,05126	3393,1	6,8084	0,04738	3386,9	6,7681
500	0,06209	3428,7	6,9282	0,05667	3422,9	6,8824	0,05209	3417,1	6,8397	0,04816	3411,3	6,7997
510	0,06304	3452,3	6,9584	0,05755	3446,7	6,9129	0,05291	3441,1	6,8705	0,04893	3435,5	6,8308
520	0,06398	3475,7	6,9882	0,05843	3470,4	6,9429	0,05373	3465,0	6,9008	0,04970	3459,6	6,8614
530	0,06492	3499,2	7,0176	0,05930	3494,0	6,9726	0,05454	3488,8	6,9307	0,05046	3483,6	6,8916
540	0,06585	3522,6	7,0466	0,06016	3517,6	7,0018	0,05534	3512,6	6,9601	0,05121	3507,6	6,9212
550	0,06678	3546,0	7,0751	0,06102	3541,2	7,0306	0,05615	3536,4	6,9892	0,05197	3531,5	6,9505
560	0,06771	3569,4	7,1034	0,06188	3564,7	7,0590	0,05694	3560,1	7,0178	0,05271	3555,4	6,9797
570	0,06863	3592,7	7,1312	0,06273	3588,2	7,0870	0,05774	3583,8	7,0460	0,05346	3579,2	7,0078
580	0,06955	3616,1	7,1588	0,06358	3611,8	7,1148	0,05853	3607,4	7,0739	0,05420	3603,1	7,0358
590	0,07046	3639,4	7,1860	0,06442	3635,3	7,1426	0,05931	3631,1	7,1015	0,05493	3626,8	7,0635

t	p = 5,5 MPa t _s = 269,97			p = 6,0 MPa t _s = 275,59			p = 6,5 MPa t _s = 280,83			p = 7,0 MPa t _s = 285,83		
	v [*] = 0,03564	i [*] = 2789,7	s [*] = 5,9307	v [*] = 0,03245	i [*] = 2784,6	s [*] = 5,8901	v [*] = 0,02973	i [*] = 2778,8	s [*] = 5,8515	v [*] = 0,02738	i [*] = 2772,6	s [*] = 5,8146
	v	i	s	v	i	s	v	i	s	v	i	s
600	0,07137	3662,8	7,2129	0,06526	3658,8	7,1692	0,06010	3654,7	7,1287	0,05566	3650,6	7,0909
610	0,07228	3686,2	7,2395	0,06610	3682,3	7,1960	0,06088	3678,3	7,1556	0,05639	3674,4	7,1180
620	0,07319	3709,6	7,2659	0,06694	3705,8	7,2224	0,06165	3702,0	7,1822	0,05712	3698,1	7,1447
630	0,07409	3733,0	7,2919	0,06777	3729,3	7,2486	0,06243	3725,6	7,2085	0,05784	3721,9	7,1712
640	0,07499	3756,4	7,3177	0,06860	3752,8	7,2745	0,06320	3749,2	7,2346	0,05857	3745,6	7,1973
650	0,07589	3779,8	7,3432	0,06943	3776,4	7,3002	0,06397	3772,9	7,2603	0,05928	3769,4	7,2232
660	0,07678	3803,3	7,3685	0,07026	3799,9	7,3256	0,06473	3796,6	7,2859	0,06000	3793,2	7,2488
670	0,07768	3826,8	7,3936	0,07108	3823,5	7,3507	0,06550	3820,3	7,3111	0,06072	3817,0	7,2742
680	0,07857	3850,3	7,4184	0,07190	3847,1	7,3756	0,06626	3844,0	7,3361	0,06143	3844,8	7,2993
690	0,07946	3873,9	7,4430	0,07272	3870,7	7,4003	0,06702	3867,7	7,3609	0,06214	3864,6	7,3242
700	0,08035	3897,5	7,4673	0,07354	3894,5	7,4248	0,06778	3891,5	7,385-	0,06285	3888,5	7,3488
710	0,08123	3921,1	7,4915	0,07436	3918,2	7,4490	0,06854	3915,3	7,409*	0,06355	3912,3	7,3732
720	0,08212	3944,8	7,5154	0,07517	3941,9	7,4730	0,06930	3939,1	7,433*	0,06426	3936,2	7,3974
730	0,08300	3968,5	7,5392	0,07599	3965,7	7,4969	0,07005	3962,9	7,4578	0,06496	3960,2	7,4214
740	0,08388	3992,2	7,5627	0,07680	3989,5	7,5205	0,07080	3986,8	7,4815	0,06566	3984,1	7,4452
750	0,08476	4016,0	7,5861	0,07761	4013,4	7,5439	0,07155	4010,7	7,5050	0,06637	4008,1	7,4687
760	0,08564	4039,8	7,6093	0,07842	4037,3	7,5672	0,07230	4034,7	7,5283	0,06706	4032,2	7,4921
770	0,08652	4063,7	7,6323	0,07923	4061,2	7,5902	0,07305	4058,7	7,5514	0,06776	4056,2	7,5153
780	0,08740	4087,6	7,6551	0,08003	4085,2	7,6131	0,07380	4082,8	7,5743	0,06846	4080,3	7,5383
790	0,08827	4111,6	7,6777	0,08084	4109,2	7,6358	0,074	4106,8	7,5971	0,06915	4104,5	7,5611
800	0,08915	4135,6	7,7002	0,08164	4133,3	7,6583	0,07529	4131,0	7,6197	0,06985	4128,7	7,5837
810	0,09002	4159,6	7,7225	0,08245	4157,4	7,6807	0,07604	4155,1	7,6420	0,07054	4152,9	7,6062
820	0,09089	4183,7	7,7446	0,08325	4181,5	7,7029	0,07678	4179,3	7,6643	0,07124	4177,1	7,6285
830	0,09176	4207,9	7,7666	0,08405	4205,7	7,7249	0,07752	4203,6	7,6864	0,07193	4201,4	7,6506
840	0,09263	4232,1	7,7885	0,08485	4230,0	7,7468	0,07826	4227,9	7,7083	0,07262	4225,8	7,6726
850	0,09350	4256,3	7,8102	0,08565	4254,3	7,7685	0,07900	4252,2	7,7301	0,07331	4250,2	7,6944
860	0,09437	4280,6	7,8317	0,08645	4278,6	7,7901	0,07974	4276,6	7,7517	0,07400	4274,6	7,7161
870	0,09524	4305,0	7,8531	0,08725	4303,0	7,8116	0,08048	4301,1	7,7732	0,07468	4299,1	7,7376
880	0,09611	4329,4	7,8744	0,08804	4327,5	7,8329	0,08122	4325,6	7,7945	0,07537	4323,7	7,7590
890	0,09697	4353,9	7,8955	0,08884	4352,0	7,8540	0,08196	4350,1	7,8157	0,07606	4348,3	7,7802
900	0,09784	4378,4	7,9165	0,08963	4376,6	7,8751	0,08269	4374,7	7,8368	0,07674	4372,9	7,8013
910	0,09870	4403,0	7,9374	0,09043	4401,2	7,8959	0,08343	4399,4	7,8577	0,07743	4397,6	7,8223
920	0,09957	4427,6	7,9581	0,09122	4425,9	7,9167	0,08416	4424,1	7,8785	0,07811	4422,4	7,8431
930	0,10043	4452,3	7,9787	0,09202	4450,6	7,9374	0,08490	4448,9	7,8992	0,07880	4447,2	7,8638
940	0,10129	4477,1	7,9992	0,09281	4475,4	7,9579	0,08563	4473,7	7,9198	0,07948	4472,0	7,8844
950	0,1022	4501,9	8,0196	0,09360	4500,2	7,9783	0,08637	4498,6	7,9402	0,08016	4496,9	7,9048
960	0,1030	4526,7	8,0398	0,09439	4525,1	7,9985	0,08710	4523,5	7,9605	0,08084	4521,9	7,9252
970	0,1039	4551,6	8,0599	0,09519	4550,1	8,0187	0,08783	4548,5	7,9807	0,08153	4546,9	7,9454
980	0,1047	4576,6	8,0799	0,09598	4575,1	8,0387	0,08856	4573,5	8,0007	0,08221	4572,0	7,9655
990	0,1056	4601,6	8,0998	0,09677	4600,1	8,0586	0,08929	4598,6	8,0207	0,08289	4597,1	7,9854
1000	0,1065	4626,7	8,1196	0,09756	4625,2	8,0784	0,09002	4623,8	8,0405	0,08357	4622,3	8,0053

3-jadval (davomi)

t	p = 7,5 MPa t _s = 290,54			p = 8,0 MPa t _s = 295,01			p = 9,0 MPa t _s = 303,35			p = 10,0 MPa t _s = 311,00		
	v [*] = 0,02533	i [*] = 2765,8	s [*] = 5,7792	v [*] = 0,02353	i [*] = 2758,6	s [*] = 5,7448	v [*] = 0,02049	i [*] = 2742,9	s [*] = 5,6790	v [*] = 0,01803	i [*] = 2725,5	s [*] = 5,6159
	v	i	s	v	i	s	v	i	s	v	i	s
0	0,0009964	7,6	0,0002	0,0009962	8,1	0,0003	0,0009957	9,1	0,0003	0,0009952	10,1	0,0003
10	0,0009968	49,3	0,1504	0,0009966	49,8	0,1503	0,0009961	50,8	0,1502	0,0009956	51,7	0,1501
20	0,0009984	91,0	0,2949	0,0009982	91,4	0,2948	0,0009978	92,4	0,2946	0,0009973	93,3	0,2944

t	p = 7,5 МПа t _с = 290,54			p = 8,0 МПа t _с = 295,01			p = 9,0 МПа t _с = 303,35			p = 10,0 МПа t _с = 311,00		
	v [*] = 0,02533	i [*] = 2765,8	s [*] = 5,7792	v [*] = 0,02353	i [*] = 2758,6	s [*] = 5,7448	v [*] = 0,02049	i [*] = 2742,9	s [*] = 5,6790	v [*] = 0,01803	i [*] = 2725,5	s [*] = 5,6159
	v	i	s	v	i	s	v	i	s	v	i	s
30	0,0010011	132,6	0,4345	0,0010009	133,0	0,4343	0,0010004	133,9	0,4340	0,0010000	134,8	0,4337
40	0,0010046	174,2	0,5695	0,0010044	174,6	0,5693	0,0010039	175,5	0,5689	0,0010035	176,4	0,5685
50	0,0010088	215,8	0,7003	0,0010086	216,2	0,7001	0,0010082	217,1	0,6996	0,0010078	217,9	0,6992
60	0,0010138	257,4	0,8273	0,0010136	257,8	0,8270	0,0010131	258,7	0,8265	0,0010127	259,5	0,8259
70	0,0010194	299,1	0,9506	0,0010191	299,5	0,9503	0,0010187	300,3	0,9497	0,0010182	301,2	0,9491
80	0,0010256	340,9	1,0705	0,0010253	341,3	1,0702	0,0010249	342,1	1,0695	0,0010244	342,9	1,0689
90	0,0010323	382,7	1,1873	0,0010321	383,1	1,1870	0,0010316	383,9	1,1863	0,0010312	384,7	1,1856
100	0,0010397	424,7	1,3013	0,0010395	425,0	1,3009	0,0010390	425,8	1,3001	0,0010385	426,5	1,2994
110	0,0010477	466,7	1,4125	0,0010474	467,1	1,4121	0,0010469	467,8	1,4113	0,0010464	468,6	1,4105
120	0,0010563	508,9	1,5213	0,0010560	509,3	1,5208	0,0010555	510,0	1,5199	0,0010549	510,7	1,5190
130	0,0010655	551,3	1,6277	0,0010652	551,6	1,6272	0,0010646	552,3	1,6262	0,0010640	553,0	1,6253
140	0,0010753	593,9	1,7319	0,0010750	594,2	1,7314	0,0010744	594,8	1,7304	0,0010738	595,5	1,7294
150	0,0010858	636,6	1,8342	0,0010855	636,9	1,8337	0,0010849	637,6	1,8326	0,0010842	638,2	1,8315
160	0,0010971	679,6	1,9347	0,0010967	679,9	1,9341	0,0010960	680,5	1,9329	0,0010954	681,1	1,9318
170	0,0011091	722,9	2,0334	0,0011087	723,2	2,0328	0,0011080	723,7	2,0316	0,0011072	724,3	2,0304
180	0,0011220	766,5	2,1307	0,0011216	766,8	2,1301	0,0011208	767,3	2,1288	0,0011200	767,8	2,1274
190	0,0011358	810,5	2,2267	0,0011353	810,7	2,2260	0,0011344	811,2	2,2246	0,0011336	811,7	2,2232
200	0,0011506	854,8	2,3215	0,0011501	855,1	2,3207	0,0011491	855,5	2,3192	0,0011482	855,9	2,3177
210	0,0011665	899,7	2,4153	0,0011660	899,9	2,4145	0,0011649	900,3	2,4128	0,0011639	900,6	2,4112
220	0,0011838	945,1	2,5083	0,0011832	945,3	2,5074	0,0011820	945,6	2,5057	0,0011808	945,9	2,5039
230	0,0012025	991,2	2,6008	0,0012019	991,3	2,5998	0,0012005	991,5	2,5979	0,0011992	991,7	2,5959
240	0,0012230	1038,0	2,6929	0,0012222	1038,0	2,6918	0,0012207	1038,2	2,6897	0,0012192	1038,3	2,6876
250	0,0012454	1085,7	2,7849	0,0012446	1085,7	2,7837	0,0012429	1085,7	2,7814	0,0012412	1085,7	2,7791
260	0,0012703	1134,4	2,8772	0,0012693	1134,3	2,8759	0,0012673	1134,2	2,8733	0,0012653	1134,1	2,8708
270	0,0012981	1184,4	2,9702	0,0012969	1184,3	2,9687	0,0012946	1184,0	2,9658	0,0012923	1183,7	2,9629
280	0,0013297	1236,1	3,0644	0,0013282	1235,8	3,0627	0,0013254	1235,3	3,0594	0,0013226	1234,8	3,0561
290	0,0013661	1289,7	3,1605	0,0013643	1289,3	3,1586	0,0013608	1288,5	3,1547	0,0013574	1287,7	3,1510
300	0,02674	2814,3	5,8644	0,02428	2786,4	5,7935	0,0014024	1344,3	3,2529	0,0013980	1343,1	3,2484
310	0,02806	2858,7	5,9412	0,02563	2835,3	5,8781	0,02145	2782,6	5,7475	0,0014471	1401,8	3,3498
320	0,02927	2898,6	6,0092	0,02684	2878,4	5,9514	0,02271	2833,9	5,8348	0,01927	2782,7	5,7131
330	0,03039	2935,5	6,0708	0,02796	2917,5	6,0169	0,02383	2878,9	5,9100	0,02045	2835,7	5,8017
340	0,03145	2970,0	6,1275	0,02899	2953,9	6,0766	0,02486	2919,6	5,9769	0,02149	2882,1	5,8780
350	0,03245	3002,7	6,1805	0,02998	2988,1	6,1319	0,02582	2957,2	6,0378	0,02244	2924,0	5,9458
360	0,03341	3034,0	6,2303	0,03092	3020,6	6,1837	0,02672	2992,5	6,0940	0,02333	2962,6	6,0073
370	0,03434	3064,1	6,2774	0,03182	3051,7	6,2325	0,02758	3026,0	6,1465	0,02416	2998,8	6,0641
380	0,03524	3093,2	6,3224	0,03268	3081,8	6,2789	0,02840	3058,0	6,1959	0,02495	3033,1	6,1170
390	0,03612	3121,6	6,3655	0,03353	3110,9	6,3232	0,02920	3088,9	6,2428	0,02571	3065,9	6,1668
400	0,03697	3149,3	6,4070	0,03435	3139,3	6,3657	0,02996	3118,8	6,2875	0,02644	3097,4	6,2139
410	0,03780	3176,4	6,4470	0,03515	3167,0	6,4066	0,03071	3147,8	6,3303	0,02714	3127,8	6,2589
420	0,03862	3203,1	6,4857	0,03593	3194,2	6,4461	0,03144	3176,1	6,3715	0,02783	3157,5	6,3019
430	0,03943	3229,3	6,5233	0,03670	3220,9	6,4843	0,03215	3203,9	6,4113	0,02850	3186,3	6,3432
440	0,04022	3255,2	6,5598	0,03745	3247,3	6,5215	0,03284	3231,1	6,4497	0,02915	3214,6	6,3831
450	0,04099	3280,7	6,5954	0,03820	3273,2	6,5577	0,03353	3257,9	6,4871	0,02978	3242,3	6,4217

t	p = 7,5 MПа t _с = 290,54			p = 8,0 MПа t _с = 295,01			p = 9,0 MПа t _с = 303,35			p = 10,0 MПа t _с = 311,00		
	v'' = 0,02533	i'' = 2765,8	s'' = 5,7792	v'' = 0,02353	i'' = 2758,6	s'' = 5,7448	v'' = 0,02049	i'' = 2742,9	s'' = 5,6790	v'' = 0,01803	i'' = 2725,5	s'' = 5,6159
	v	i	s	v	i	s	v	i	s	v	i	s
460	0,04176	3306,1	6,6302	0,03893	3298,9	6,5929	0,03420	3284,4	6,5234	0,03041	3269,5	6,4591
470	0,04252	3331,1	6,6642	0,03965	3324,3	6,6274	0,03486	3310,5	6,5588	0,03102	3296,4	6,4955
480	0,04327	3356,0	6,6974	0,04036	3349,5	6,6611	0,03551	3336,3	6,5933	0,03163	3322,9	6,5310
490	0,04402	3380,8	6,7300	0,04107	3374,5	6,6940	0,03616	3361,9	6,6271	0,03223	3349,1	6,5655
500	0,04475	3405,3	6,7620	0,04177	3399,4	6,7264	0,03680	3387,3	6,6601	0,03281	3375,1	6,5993
510	0,04548	3429,8	6,7935	0,04246	3424,1	6,7581	0,03743	3412,5	6,6925	0,03339	3400,8	6,6324
520	0,04620	3454,1	6,8244	0,04315	3448,6	6,7893	0,03805	3437,6	6,7243	0,03397	3426,3	6,6648
530	0,04692	3478,4	6,8547	0,04383	3473,1	6,8199	0,03867	3462,5	6,7555	0,03454	3451,7	6,6965
540	0,04763	3502,6	6,8847	0,04450	3497,5	6,8501	0,03928	3487,2	6,7861	0,03510	3476,9	6,7277
550	0,04834	3526,7	6,9141	0,04517	3521,8	6,8798	0,03989	3511,9	6,8163	0,03566	3501,9	6,7584
560	0,04905	3550,7	6,9432	0,04584	3546,0	6,9091	0,04049	3536,5	6,8460	0,03621	3526,9	6,7885
570	0,04975	3574,7	6,9718	0,04650	3570,2	6,9379	0,04109	3561,0	6,8752	0,03676	3551,8	6,8182
580	0,05044	3598,7	7,0001	0,04716	3594,3	6,9663	0,04168	3585,4	6,9040	0,03730	3576,5	6,8474
590	0,05113	3622,6	7,0280	0,04781	3618,4	6,9944	0,04227	3609,8	6,9324	0,03784	3601,2	6,8761
600	0,05182	3646,5	7,0555	0,04846	3642,4	7,0221	0,04286	3634,2	6,9605	0,03838	3625,8	6,9045
610	0,05251	3670,4	7,0827	0,04911	3666,4	7,0495	0,04344	3658,5	6,9881	0,03891	3650,4	6,9325
620	0,05319	3694,3	7,1096	0,04975	3690,5	7,0765	0,04403	3682,7	7,0155	0,03944	3674,9	6,9601
630	0,05387	3718,2	7,1362	0,05040	3714,5	7,1032	0,04460	3707,0	7,0424	0,03997	3699,4	6,9874
640	0,05455	3742,0	7,1625	0,05104	3738,4	7,1296	0,04518	3731,2	7,0691	0,04049	3723,9	7,0143
650	0,05523	3765,9	7,1885	0,05167	3762,4	7,1557	0,04575	3755,4	7,0955	0,04102	3748,3	7,0409
660	0,05590	3789,8	7,2142	0,05231	3786,4	7,1816	0,04632	3779,6	7,1216	0,04154	3772,7	7,0672
670	0,05657	3813,7	7,2397	0,05294	3810,4	7,2072	0,04689	3803,8	7,1473	0,04205	3797,1	7,0932
680	0,05724	3837,6	7,2649	0,05357	3834,4	7,2325	0,04746	3828,0	7,1728	0,04257	3821,5	7,1189
690	0,05790	3861,5	7,2898	0,05420	3858,4	7,2575	0,04802	3852,2	7,1981	0,04308	3845,9	7,1444
700	0,05857	3885,4	7,3145	0,05483	3882,4	7,2823	0,04859	3876,4	7,2231	0,04359	3870,3	7,1696
710	0,05923	3909,4	7,3390	0,05545	3906,5	7,3069	0,04915	3900,6	7,2478	0,04410	3894,7	7,1945
720	0,05989	3933,4	7,3633	0,05607	3930,5	7,3313	0,04971	3924,8	7,2724	0,04461	3919,0	7,2192
730	0,06055	3957,4	7,3874	0,05669	3954,6	7,3554	0,05026	3949,0	7,2967	0,04512	3943,4	7,2436
740	0,06121	3981,4	7,4112	0,05731	3978,7	7,3793	0,05082	3973,3	7,3207	0,04562	3967,9	7,2678
750	0,06187	4005,5	7,4348	0,05793	4002,9	7,4030	0,05137	3997,6	7,3446	0,04613	3992,3	7,2918
760	0,06252	4029,6	7,4583	0,05855	4027,0	7,4265	0,05193	4021,9	7,3682	0,04663	4016,7	7,3156
770	0,06318	4053,7	7,4815	0,05917	4051,2	7,4498	0,05248	4046,2	7,3916	0,04713	4041,2	7,3392
780	0,06383	4077,9	7,5046	0,05978	4075,5	7,4729	0,05303	4070,6	7,4149	0,04763	4065,7	7,3625
790	0,06448	4102,1	7,5275	0,06039	4099,7	7,4959	0,05358	4095,0	7,4379	0,04813	4090,2	7,3857
800	0,06513	4126,3	7,5502	0,06101	4124,0	7,5186	0,05413	4119,4	7,4608	0,04862	4114,7	7,4087
810	0,06578	4150,6	7,5726	0,06162	4148,3	7,5412	0,05467	4143,8	7,4834	0,04912	4139,3	7,4314
820	0,06643	4174,9	7,5950	0,06223	4172,7	7,5636	0,05522	4168,3	7,5059	0,04962	4163,9	7,4540
830	0,06708	4199,3	7,6172	0,06284	4197,1	7,5858	0,05577	4192,8	7,5282	0,05011	4188,5	7,4764
840	0,06773	4223,7	7,6392	0,06344	4221,6	7,6078	0,05631	4217,4	7,5504	0,05060	4213,1	7,4987
850	0,06837	4248,1	7,6610	0,06405	4246,1	7,6298	0,05685	4241,9	7,5724	0,05109	4237,8	7,5208
860	0,06902	4272,6	7,6828	0,06466	4270,6	7,6515	0,05740	4266,6	7,5942	0,05159	4262,6	7,5427
870	0,06966	4297,2	7,7043	0,06526	4295,2	7,6731	0,05794	4291,3	7,6159	0,05208	4287,3	7,5645
880	0,07030	4321,8	7,7257	0,06587	4319,8	7,6946	0,05848	4316,0	7,6375	0,05257	4312,2	7,5861
890	0,07095	4346,4	7,7470	0,06647	4344,5	7,7159	0,05902	4340,8	7,6588	0,05305	4337,0	7,6075
900	0,07159	4371,1	7,7682	0,06708	4369,3	7,7371	0,05956	4365,6	7,6801	0,05354	4361,9	7,6289
910	0,07223	4395,8	7,7892	0,06768	4394,0	7,7581	0,06010	4390,5	7,7012	0,05403	4386,9	7,6500
920	0,07287	4420,6	7,8100	0,06828	4418,9	7,7790	0,06063	4415,4	7,7222	0,05452	4411,9	7,6711
930	0,07351	4445,5	7,8308	0,06888	4443,8	7,7998	0,06117	4440,3	7,7430	0,05500	4436,9	7,6920
940	0,07415	4470,4	7,8514	0,06948	4468,7	7,8204	0,06171	4465,3	7,7637	0,05549	4462,0	7,7127
950	0,07479	4495,3	7,8718	0,07008	4493,7	7,8409	0,06224	4490,4	7,7843	0,05597	4487,1	7,7334
960	0,07542	4520,3	7,8922	0,07068	4518,7	7,8613	0,06278	4515,5	7,8047	0,05646	4512,3	7,7539
970	0,07606	4545,4	7,9124	0,07128	4543,8	7,8816	0,06331	4540,7	7,8250	0,05694	4537,5	7,7742
980	0,07670	4570,5	7,9326	0,07188	4568,9	7,9017	0,06385	4565,9	7,8452	0,05742	4562,8	7,7945
990	0,07734	4595,6	7,9525	0,07248	4594,1	7,9217	0,06438	4591,1	7,8653	0,05791	4588,1	7,8146
1000	0,07797	4620,8	7,9724	0,07307	4619,4	7,9416	0,06492	4616,4	7,8853	0,05839	4613,5	7,8346

3-jadval (davomi)

t	p = 10,5 МПа t _г = 314,61			p = 11,0 МПа t _г = 318,08			p = 11,5 МПа t _г = 324,68			p = 12,0 МПа t _г = 324,68		
	v ^г = 0,01697	i ^г = 2716,1	s ^г = 5,5850	v ^г = 0,01599	i ^г = 2706,4	s ^г = 5,5545	v ^г = 0,01510	i ^г = 2696,2	s ^г = 5,5243	v ^г = 0,01427	i ^г = 2685,6	s ^г = 5,4941
	v	i	s	v	i	s	v	i	s	v	i	s
0	0,0009950	10,6	0,0004	0,0009947	11,1	0,0004	0,0009945	11,6	0,0004	0,0009942	12,1	0,0004
10	0,0009954	52,2	0,1500	0,0009952	52,7	0,1500	0,0009949	53,2	0,1499	0,0009947	53,6	0,1499
20	0,0009971	93,8	0,2943	0,0009969	94,2	0,2941	0,0009967	94,7	0,2940	0,0009964	95,2	0,2939
30	0,0009998	135,3	0,4336	0,0009996	135,7	0,4334	0,0009993	136,2	0,4333	0,0009991	136,6	0,4331
40	0,0010033	176,8	0,5684	0,0010031	177,3	0,5682	0,0010029	177,7	0,5680	0,0010026	178,1	0,5678
50	0,0010075	218,4	0,6990	0,0010073	218,8	0,6987	0,0010071	219,2	0,6985	0,0010069	219,7	0,6983
60	0,0010125	259,9	0,8257	0,0010122	260,4	0,8254	0,0010120	260,8	0,8252	0,0010118	261,2	0,8249
70	0,0010180	301,6	0,9488	0,0010178	302,0	0,9485	0,0010176	302,4	0,9482	0,0010173	302,8	0,9479
80	0,0010242	343,3	1,0686	0,0010239	343,7	1,0682	0,0010237	344,1	1,0679	0,0010235	344,5	1,0676
90	0,0010309	385,0	1,1852	0,0010307	385,4	1,1849	0,0010305	385,8	1,1845	0,0010302	386,2	1,1842
100	0,0010382	426,9	1,2990	0,0010380	427,3	1,2986	0,0010378	427,7	1,2982	0,0010375	428,1	1,2978
110	0,0010462	468,9	1,4100	0,0010459	469,3	1,4096	0,0010456	469,7	1,4092	0,0010454	470,1	1,4088
120	0,0010547	511,1	1,5186	0,0010544	511,4	1,5182	0,0010541	511,8	1,5177	0,0010539	512,1	1,5173
130	0,0010638	553,3	1,6248	0,0010635	553,7	1,6244	0,0010632	554,0	1,6239	0,0010629	554,4	1,6234
140	0,0010735	595,8	1,7289	0,0010732	596,1	1,7284	0,0010729	596,5	1,7279	0,0010726	596,8	1,7274
150	0,0010839	638,5	1,8310	0,0010836	638,8	1,8304	0,0010833	639,1	1,8299	0,0010829	639,4	1,8294
160	0,0010950	681,4	1,9312	0,0010947	681,7	1,9306	0,0010943	682,0	1,9300	0,0010940	682,3	1,9295
170	0,0011069	724,6	2,0297	0,0011065	724,9	2,0291	0,0011061	725,2	2,0285	0,0011058	725,4	2,0279
180	0,0011196	768,1	2,1268	0,0011192	768,3	2,1261	0,0011188	768,6	2,1255	0,0011184	768,9	2,1248
190	0,0011331	811,9	2,2224	0,0011327	812,1	2,2217	0,0011323	812,4	2,2210	0,0011318	812,6	2,2204
200	0,0011477	856,1	2,3169	0,0011472	856,4	2,3162	0,0011468	856,6	2,3154	0,0011463	856,8	2,3147
210	0,0011634	900,8	2,4104	0,0011628	901,0	2,4096	0,0011623	901,2	2,4088	0,0011618	901,4	2,4080
220	0,0011803	946,0	2,5030	0,0011797	946,2	2,5021	0,0011791	946,3	2,5012	0,0011785	946,5	2,5004
230	0,0011986	991,8	2,5950	0,0011979	992,0	2,5940	0,0011973	992,1	2,5931	0,0011966	992,2	2,5921
240	0,0012185	1038,4	2,6865	0,0012178	1038,5	2,6855	0,0012170	1038,5	2,6845	0,0012163	1038,6	2,6834
250	0,0012403	1085,7	2,7779	0,0012395	1085,8	2,7768	0,0012387	1085,8	2,7757	0,0012378	1085,8	2,7745
260	0,0012644	1134,1	2,8695	0,0012634	1134,0	2,8682	0,0012625	1134,0	2,8670	0,0012615	1134,0	2,8657
270	0,0012911	1183,6	2,9615	0,0012900	1183,5	2,9601	0,0012889	1183,4	2,9587	0,0012878	1183,3	2,9573
280	0,0013213	1234,6	3,0545	0,0013199	1234,4	3,0529	0,0013186	1234,1	3,0513	0,0013173	1233,9	3,0498
290	0,0013557	1287,4	3,1491	0,0013541	1287,0	3,1473	0,0013524	1286,7	3,1454	0,0013508	1286,3	3,1436
300	0,0013959	1342,5	3,2462	0,0013938	1342,0	3,2440	0,0013918	1341,4	3,2418	0,0013898	1340,9	3,2397
310	0,0014443	1400,9	3,3471	0,0014415	1400,1	3,3445	0,0014388	1399,3	3,3419	0,0014361	1398,5	3,3393
320	0,01773	2753,5	5,6484	0,01628	2721,1	5,5793	0,0014974	1461,5	3,4477	0,0014937	1460,3	3,4444
330	0,01895	2811,9	5,7460	0,01757	2786,4	5,6885	0,01626	2758,6	5,6285	0,01502	2728,1	5,5650
340	0,02002	2861,8	5,8281	0,01866	2840,4	5,7775	0,01739	2817,7	5,7257	0,01621	2793,5	5,6725
350	0,02098	2906,3	5,9000	0,01963	2887,8	5,8541	0,01838	2868,4	5,8077	0,01722	2848,0	5,7607
355	0,02142	2927,0	5,9331	0,02008	2909,6	5,8890	0,01884	2891,5	5,8447	0,01768	2872,6	5,8000
360	0,02186	2946,9	5,9646	0,02051	2930,5	5,9221	0,01927	2913,6	5,8796	0,01812	2895,9	5,8369
365	0,02228	2966,0	5,9948	0,02093	2950,6	5,9537	0,01969	2934,6	5,9127	0,01854	2918,0	5,8717
370	0,02268	2984,6	6,0238	0,02133	2969,9	5,9839	0,02009	2954,8	5,9443	0,01894	2939,1	5,9047

t	$\rho = 10,5 \text{ MPa}$ $t_s = 314,61$			$\rho = 11,0 \text{ MPa}$ $t_s = 318,08$			$\rho = 11,5 \text{ MPa}$ $t_s = 324,68$			$\rho = 12,0 \text{ MPa}$ $t_s = 324,68$		
	$v^* =$ 0,01697	$i^* =$ 2716,1	$s^* =$ 5,5850	$v^* =$ 0,01599	$i^* =$ 2706,4	$s^* =$ 5,5545	$v^* =$ 0,01510	$i^* =$ 2696,2	$s^* =$ 5,5243	$v^* =$ 0,01427	$i^* =$ 2685,6	$s^* =$ 5,4941
	v	i	s	v	i	s	v	i	s	v	i	s
375	0,02308	3002,6	6,0517	0,02172	2988,7	6,0129	0,02048	2974,3	5,9744	0,01933	2959,5	5,9362
380	0,02346	3020,2	6,0786	0,02210	3006,8	6,0408	0,02086	2993,2	6,0034	0,01971	2979,1	5,9664
385	0,02384	3037,3	6,1047	0,02248	3024,5	6,0678	0,02122	3011,5	6,0314	0,02007	2998,1	5,9953
390	0,02421	3054,0	6,1300	0,02284	3041,8	6,0939	0,02158	3029,3	6,0583	0,02043	3016,5	6,0232
395	0,02457	3070,3	6,1546	0,02319	3058,6	6,1192	0,02193	3046,7	6,0844	0,02077	3034,4	6,0501
400	0,02492	3086,4	6,1785	0,02354	3075,1	6,1438	0,02221	3063,6	6,1097	0,02111	3051,9	6,0762
405	0,02527	3102,1	6,2018	0,02388	3091,3	6,1677	0,02261	3080,2	6,1343	0,02144	3069,0	6,1015
410	0,02561	3117,6	6,2246	0,02421	3107,2	6,1911	0,02294	3096,5	6,1583	0,02176	3085,7	6,1261
415	0,02595	3132,9	6,2468	0,02454	3122,8	6,2138	0,02326	3112,5	6,1816	0,02208	3102,1	6,1500
420	0,02628	3147,9	6,2686	0,02487	3138,1	6,2361	0,02357	3128,3	6,2044	0,02239	3118,2	6,1733
425	0,02661	3162,7	6,2899	0,02519	3153,3	6,2579	0,02389	3143,7	6,2266	0,02269	3134,0	6,1960
430	0,02693	3177,3	6,3108	0,02550	3168,2	6,2792	0,02419	3159,0	6,2484	0,02299	3149,6	6,2182
435	0,02725	3191,8	6,3313	0,02581	3183,0	6,3001	0,02449	3174,0	6,2697	0,02329	3164,9	6,2400
440	0,02756	3206,1	6,3514	0,02611	3197,6	6,3206	0,02479	3188,9	6,2906	0,02358	3180,1	6,2613
445	0,02787	3220,3	6,3712	0,02642	3212,0	6,3407	0,02509	3203,5	6,3111	0,02387	3195,0	6,2822
450	0,02818	3234,3	6,3907	0,02672	3226,2	6,3605	0,02538	3218,1	6,3312	0,02415	3209,8	6,3027
460	0,02878	3262,0	6,4287	0,02730	3254,3	6,3991	0,02595	3246,6	6,3705	0,02471	3238,8	6,3425
470	0,02938	3289,2	6,4656	0,02788	3282,0	6,4366	0,02651	3274,7	6,4084	0,02525	3267,3	6,3811
480	0,02996	3316,1	6,5015	0,02845	3309,2	6,4730	0,02706	3302,3	6,4453	0,02579	3295,2	6,4185
490	0,03054	3342,6	6,5365	0,02900	3336,1	6,5084	0,02760	3329,5	6,4812	0,02631	3322,8	6,4548
500	0,03110	3368,9	6,5706	0,02955	3362,6	6,5430	0,02813	3356,3	6,5162	0,02683	3350,0	6,4902
510	0,03166	3394,9	6,6041	0,03009	3388,9	6,5767	0,02866	3382,9	6,5503	0,02734	3376,8	6,5247
520	0,03222	3420,6	6,6368	0,03063	3414,9	6,6098	0,02917	3409,2	6,5837	0,02784	3403,4	6,5584
530	0,03276	3446,2	6,6688	0,03115	3440,7	6,6421	0,02968	3435,2	6,6163	0,02833	3429,7	6,5914
540	0,03331	3471,6	6,7003	0,03168	3466,4	6,6738	0,03019	3461,1	6,6483	0,02882	3455,8	6,6237
550	0,03384	3496,9	6,7312	0,03219	3491,9	6,7050	0,03069	3486,8	6,6797	0,02930	3481,7	6,6553
560	0,03437	3522,1	6,7615	0,03270	3517,2	6,7356	0,03118	3512,3	6,7106	0,02978	3507,4	6,6864
570	0,03490	3547,1	6,7914	0,03321	3542,4	6,7657	0,03167	3537,7	6,7409	0,03026	3533,0	6,7169
580	0,03542	3572,0	6,8208	0,03371	3567,5	6,7953	0,03215	3563,0	6,7707	0,03072	3558,4	6,7469
590	0,03594	3596,9	6,8498	0,03421	3592,5	6,8244	0,03264	3588,2	6,8000	0,03119	3583,8	6,7764
600	0,03646	3621,7	6,8783	0,03471	3617,5	6,8531	0,03311	3613,2	6,8289	0,03165	3609,0	6,8055
610	0,03697	3646,4	6,9064	0,03520	3642,3	6,8814	0,03359	3638,2	6,8574	0,03211	3634,2	6,8341
620	0,03748	3671,0	6,9342	0,03569	3667,1	6,9094	0,03406	3663,2	6,8854	0,03256	3659,2	6,8624
630	0,03798	3695,7	6,9616	0,03618	3691,9	6,9369	0,03453	3688,1	6,9131	0,03302	3684,2	6,8902
640	0,03849	3720,2	6,9887	0,03666	3716,6	6,9641	0,03499	3712,9	6,9405	0,03346	3709,2	6,9177
650	0,03899	3744,8	7,0154	0,03714	3741,2	6,9910	0,03546	3737,6	6,9674	0,03391	3734,1	6,9448
660	0,03948	3769,3	7,0418	0,03762	3765,8	7,0175	0,03592	3762,4	6,9941	0,03435	3758,9	6,9716
670	0,03998	3793,8	7,0679	0,03809	3790,4	7,0437	0,03637	3787,1	7,0204	0,03480	3783,7	6,9980
680	0,04047	3818,3	7,0938	0,03857	3815,0	7,0696	0,03683	3811,8	7,0465	0,03523	3808,5	7,0241
690	0,04097	3842,8	7,1193	0,03904	3839,6	7,0953	0,03728	3836,4	7,0722	0,03567	3833,3	7,0500
700	0,04146	3867,2	7,1446	0,03951	3864,2	7,1207	0,03773	3861,1	7,0977	0,03611	3858,0	7,0756
710	0,04194	3891,7	7,1696	0,03998	3888,7	7,1458	0,03818	3885,7	7,1229	0,03654	3882,8	7,1008
720	0,04243	3916,2	7,1944	0,04044	3913,3	7,1706	0,03863	3910,4	7,1478	0,03697	3907,5	7,1259

t	p = 10,5 МПа t _g = 314,61			p = 11,0 МПа t _g = 318,08			p = 11,5 МПа t _g = 324,68			p = 12,0 МПа t _g = 324,68		
	v ⁺	i ⁺	s ⁺	v ⁺	i ⁺	s ⁺	v ⁺	i ⁺	s ⁺	v ⁺	i ⁺	s ⁺
	0,01697	2716,1	5,5850	0,01599	2706,4	5,5545	0,01510	2696,2	s ⁺ = 5,5243	0,01427	2685,6	5,4941
v	i	s	v	i	s	v	i	s	v	i	s	
730	0,04291	3940,6	7,2189	0,04091	3937,8	7,1952	0,03908	3935,0	7,1725	0,03740	3932,2	7,1506
740	0,04340	3965,1	7,2432	0,04137	3962,4	7,2196	0,03952	3959,7	7,1969	0,03783	3956,9	7,1751
750	0,04388	3989,6	7,2672	0,04183	3987,0	7,2437	0,03997	3984,3	7,2211	0,03826	3981,6	7,1994
760	Of *43*	4014,1	7,2911	0,04229	4011,6	7,2676	0,04041	4009,0	7,2451	0,03868	4006,4	7,2235
770	0,04484	4038,7	7,3147	0,04275	4036,2	7,2913	0,04085	4033,6	7,2689	0,03911	4031,1	7,2473
780	0,04531	4063,2	7,3382	0,04321	4060,8	7,3148	0,04129	4058,3	7,2924	0,03953	4055,9	7,2709
790	0,04579	4087,8	7,3614	0,04367	4085,4	7,3381	0,04173	4083,0	7,3158	0,03995	4080,6	7,2943
800	0,04627	4112,4	7,3844	0,04412	4110,1	7,3612	0,04216	4107,7	7,3389	0,04037	4105,4	7,3175

3-jadval (davomi)

t	p = 12,5 МПа t _g = 327,82			p = 13,0 МПа t _g = 330,86			p = 13,5 МПа t _g = 333,81			p = 14,0 МПа t _g = 336,67		
	v ⁺	i ⁺	s ⁺	v ⁺	i ⁺	s ⁺	v ⁺	i ⁺	s ⁺	v ⁺	i ⁺	s ⁺
	0,01350	2674,5	5,4640	0,01279	2662,9	5,4339	0,01212	2650,8	s ⁺ = 5,4036	0,01149	2638,1	5,3730
v	i	s	v	i	s	v	i	s	v	i	s	
0	0,0009940	12,6	0,0004	0,0009937	13,1	0,0004	0,0009935	13,6	0,0004	0,0009932	14,1	0,0004
10	0,0009945	54,1	0,1498	0,0009943	54,6	0,1497	0,0009940	55,1	0,1497	0,0009938	55,6	0,1496
20	0,0009962	95,6	0,2938	0,0009960	96,1	0,2937	0,0009958	96,5	0,2936	0,0009955	97,0	0,2935
30	0,0009989	137,1	0,4329	0,0009987	137,5	0,4328	0,0009985	138,0	0,4326	0,0009983	138,4	0,4325
40	0,0010024	178,6	0,5676	0,0010022	179,0	0,5674	0,0010020	179,5	0,5672	0,0010018	179,9	0,5670
50	0,0010067	220,1	0,6980	0,0010065	220,5	0,6978	0,0010062	220,9	0,6976	0,0010060	221,4	0,6973
60	0,0010116	261,6	0,8246	0,0010114	262,0	0,8244	0,0010112	262,5	0,8241	0,0010109	262,9	0,8238
70	0,0010171	303,2	0,9476	0,0010169	303,6	0,9473	0,0010167	304,0	0,9470	0,0010165	304,4	0,9468
80	0,0010233	344,7	1,0673	0,0010230	345,3	1,0670	0,0010228	345,7	1,0666	0,0010226	346,1	1,0663
90	0,0010300	386,6	1,1838	0,0010297	387,0	1,1835	0,0010295	387,4	1,1831	0,0010293	387,8	1,1828
100	0,0010373	428,4	1,2975	0,0010370	428,8	1,2971	0,0010368	429,2	1,2967	0,0010365	429,6	1,2963
110	0,0010451	470,4	1,4084	0,0010449	470,8	1,4080	0,0010446	471,1	1,4076	0,0010444	471,5	1,4072
120	0,0010536	512,5	1,5168	0,0010533	512,8	1,5164	0,0010531	513,2	1,5160	0,0010528	513,5	1,5155
130	0,0010626	554,7	1,6229	0,0010623	555,1	1,6225	0,0010621	555,4	1,6220	0,0010618	555,7	1,6215
140	0,0010723	597,1	1,7269	0,0010720	597,5	1,7264	0,0010717	597,8	1,7259	0,0010714	598,1	1,7254
150	0,0010826	639,8	1,8288	0,0010823	640,1	1,8283	0,0010820	640,4	1,8278	0,0010817	640,7	1,8272
160	0,0010936	682,6	1,9289	0,0010933	682,9	1,9283	0,0010930	683,2	1,9278	0,0010926	683,5	1,9272
170	0,0011054	725,7	2,0273	0,0011050	726,0	2,0267	0,0011047	726,3	2,0261	0,0011043	726,6	2,0255
180	0,0011180	769,1	2,1242	0,0011176	769,4	2,1235	0,0011172	769,7	2,1229	0,0011168	769,9	2,1222
190	0,0011314	812,9	2,2197	0,0011310	813,1	2,2190	0,0011306	813,4	2,2183	0,0011301	813,6	2,2176
200	0,0011458	857,0	2,3139	0,0011453	857,2	2,3132	0,0011449	857,4	2,3124	0,0011444	857,7	2,3117
210	0,0011613	901,6	2,4072	0,0011608	901,8	2,4064	0,0011603	902,0	2,4056	0,0011598	902,2	2,4048
220	0,0011780	946,7	2,4995	0,0011774	946,8	2,4986	0,0011768	947,0	2,4978	0,0011763	947,2	2,4969
230	0,0011960	992,3	2,5912	0,0011954	992,5	2,5903	0,0011947	992,6	2,5893	0,0011941	992,7	2,5884
240	0,0012156	1038,7	2,6824	0,0012149	1038,8	2,6814	0,0012142	1038,9	2,6804	0,0012135	1039,0	2,6794
250	0,0012370	1085,8	2,7734	0,0012362	1085,9	2,7723	0,0012354	1085,9	2,7712	0,0012346	1086,0	2,7701
260	0,0012606	1133,9	2,8645	0,0012596	1133,9	2,8632	0,0012587	1133,9	2,8620	0,0012578	1133,9	2,8608

t	p = 12,5 MPa t _s = 327,82			p = 13,0 MPa t _s = 330,86			p = 13,5 MPa t _s = 333,81			p = 14,0 MPa t _s = 336,67		
	v ⁻ 0,01350	i ⁻ 2674,5	s ⁻ 5,4640	v ⁻ 0,01279	i ⁻ 2662,9	s ⁻ 5,4339	v ⁻ 0,01212	i ⁻ 2650,8	s ⁻ 5,4036	v ⁻ 0,01149	i ⁻ 2638,1	s ⁻ 5,3730
	v	i	s	v	i	s	v	i	s	v	i	s
270	0,0012867	1183,2	2,9559	0,0012856	1183,0	2,9546	0,0012845	1183,0	2,9532	0,0012835	1182,9	2,9518
280	0,0013160	1233,7	3,0482	0,0013147	1233,5	3,0466	0,0013134	1233,3	3,0451	0,0013121	1233,1	3,0436
290	0,0013493	1286,0	3,1418	0,0013477	1285,7	3,1401	0,0013461	1285,4	3,1383	0,0013446	1285,0	3,1366
300	0,0013878	1340,4	3,2376	0,0013858	1339,9	3,2355	0,0013839	1339,4	3,2335	0,0013820	1339,0	3,2315
310	0,0014335	1397,7	3,3367	0,0014310	1397,0	3,3342	0,0014285	1396,3	3,3318	0,0014260	1395,6	3,3293
320	0,0014901	1459,1	3,4412	0,0014865	1458,0	3,4380	0,0014831	1456,9	3,4349	0,0014797	1455,9	3,4319
330	0,01383	2693,9	5,4963	0,0015591	1525,2	3,5503	0,0015539	1523,5	3,5462	0,0015489	1521,8	3,5421
340	0,01509	2767,3	5,6171	0,01403	2738,9	5,5589	0,01300	2707,6	5,4968	0,01200	2672,4	5,4291
350	0,01614	2826,5	5,7128	0,01512	2803,6	5,6635	0,01415	2779,2	5,6126	0,01323	2752,9	5,5595
355	0,01661	2852,8	5,7548	0,01560	2831,8	5,7087	0,01465	2809,7	5,6614	0,01375	2786,2	5,6126
360	0,01705	2877,4	5,7939	0,01605	2858,1	5,7503	0,01512	2837,8	5,7059	0,01423	2816,4	5,6605
365	0,01748	2900,7	5,8306	0,01648	2882,8	5,7891	0,01555	2864,0	5,7471	0,01467	2844,3	5,7045
370	0,01788	2922,9	5,8652	0,01689	2906,1	5,8255	0,01596	2888,6	5,7856	0,01509	2870,4	5,7452
375	0,01827	2944,2	5,8981	0,01728	2928,3	5,8600	0,01636	2912,0	5,8217	0,01549	2894,9	5,7832
380	0,01864	2964,6	5,9295	0,01765	2949,6	5,8927	0,01673	2934,2	5,8559	0,01587	2918,3	5,8190
385	0,01901	2984,3	5,9595	0,01802	2970,1	5,9240	0,01709	2955,5	5,8885	0,01623	2940,5	5,8530
390	0,01936	3003,4	5,9884	0,01836	2989,9	5,9539	0,01744	2976,1	5,9195	0,01658	2961,8	5,8853
395	0,01970	3021,9	6,0162	0,01870	3009,0	5,9827	0,01778	2995,9	5,9493	0,01691	2982,4	5,9161
400	0,02003	3039,9	6,0431	0,01903	3027,6	6,0104	0,01811	3015,1	5,9779	0,01724	3002,2	5,9457
405	0,02036	3057,5	6,0691	0,01936	3045,7	6,0372	0,01843	3033,7	6,0055	0,01756	3021,5	5,9742
410	0,02067	3074,7	6,0944	0,01967	3063,4	6,0631	0,01874	3051,9	6,0322	0,01787	3040,2	6,0017
415	0,02099	3091,5	6,1189	0,01998	3080,6	6,0883	0,01904	3069,6	6,0581	0,01817	3058,4	6,0282
420	0,02129	3108,0	6,1428	0,02028	3097,5	6,1127	0,01934	3086,9	6,0832	0,01846	3076,1	6,0539
425	0,02159	3124,1	6,1660	0,02057	3114,1	6,1365	0,01963	3103,9	6,1075	0,01875	3093,5	6,0789
430	0,02189	3140,1	6,1887	0,02086	3130,4	6,1598	0,01991	3120,5	6,1313	0,01903	3110,5	6,1032
435	0,02218	3155,7	6,2109	0,02115	3146,4	6,1824	0,02019	3136,9	6,1544	0,01931	3127,2	6,1269
440	0,02246	3171,1	6,2326	0,02143	3162,1	6,2046	0,02047	3152,9	6,1770	0,01958	3143,6	6,1499
445	0,02274	3186,4	6,2539	0,02170	3177,6	6,2262	0,02074	3168,7	6,1991	0,01984	3159,7	6,1725
450	0,02302	3201,4	6,2748	0,02198	3192,9	6,2475	0,02101	3184,3	6,2207	0,02010	3175,6	6,1945
460	0,02357	3230,9	6,3153	0,02251	3222,9	6,2887	0,02153	3214,8	6,2627	0,02062	3206,7	6,2371
470	0,02410	3259,8	6,3545	0,02303	3252,3	6,3285	0,02204	3244,6	6,3030	0,02112	3236,9	6,2782
480	0,02462	3288,2	6,3924	0,02354	3281,0	6,3669	0,02253	3273,8	6,3420	0,02160	3266,5	6,3177
490	0,02513	3316,1	6,4292	0,02404	3309,3	6,4042	0,02302	3302,5	6,3798	0,02208	3295,6	6,3560
500	0,02563	3343,6	6,4650	0,02452	3337,1	6,4404	0,02350	3330,6	6,4165	0,02255	3324,1	6,3931
510	0,02613	3370,7	6,4998	0,02501	3364,6	6,4757	0,02397	3358,4	6,4521	0,02300	3352,1	6,4292
520	0,02661	3397,5	6,5339	0,02548	3391,7	6,5101	0,02443	3385,8	6,4869	0,02345	3379,8	6,4643
530	0,02709	3424,1	6,5672	0,02594	3418,5	6,5437	0,02488	3412,8	6,5208	0,02390	3407,2	6,4986
540	0,02757	3450,4	6,5997	0,02641	3445,1	6,5765	0,02533	3439,6	6,5540	0,02433	3434,2	6,5320
550	0,02803	3476,5	6,6317	0,02686	3471,4	6,6087	0,02577	3466,2	6,5864	0,02476	3461,0	6,5648
560	0,02850	3502,5	6,6630	0,02731	3497,5	6,6403	0,02621	3492,5	6,6183	0,02519	3487,5	6,5968
570	0,02895	3528,3	6,6937	0,02775	3523,5	6,6713	0,02664	3518,7	6,6495	0,02561	3513,9	6,6283
580	0,02941	3553,9	6,7239	0,02819	3549,3	6,7017	0,02707	3544,7	6,6801	0,02602	3540,1	6,6591
590	0,02986	3579,4	6,7537	0,02863	3575,0	6,7316	0,02749	3570,5	6,7102	0,02644	3566,1	6,6894

t	p = 12,5 MPa $t_g = 327,82$			p = 13,0 MPa $t_g = 330,86$			p = 13,5 MPa $t_g = 333,81$			p = 14,0 MPa $t_g = 336,67$		
	$v'' =$ 0,01350	$i'' =$ 2674,5	$s'' =$ 5,4640	$v'' =$ 0,01279	$i'' =$ 2662,9	$s'' =$ 5,4339	$v'' =$ 0,01212	$i'' =$ 2650,8	$s'' =$ 5,4036	$v'' =$ 0,01149	$i'' =$ 2638,1	$s'' =$ 5,3730
	v	i	s	v	i	s	v	i	s	v	i	s
600	0,03031	3604,8	6,7829	0,02906	3600,5	6,7610	0,02791	3596,2	6,7398	0,02684	3591,9	6,7192
610	0,03075	3630,1	6,8117	0,02949	3626,0	6,7900	0,02833	3621,8	6,7690	0,02725	3617,7	6,7486
620	0,03119	3655,3	6,8401	0,02992	3651,3	6,8185	0,02874	3647,3	6,7977	0,02765	3643,3	6,7774
630	0,03162	3680,4	6,8681	0,03034	3676,6	6,8467	0,02915	3672,7	6,8259	0,02805	3668,8	6,8058
640	0,03206	3705,5	6,8957	0,03076	3701,8	6,8744	0,02956	3698,0	6,8538	0,02844	3694,3	6,8339
650	0,03249	3730,5	6,9229	0,03118	3726,9	6,9018	0,02996	3723,3	6,8813	0,02883	3719,7	6,8615
660	0,03292	3755,4	6,9498	0,03159	3752,0	6,9288	0,03036	3748,5	6,9085	0,02922	3745,0	6,8888
670	0,03334	3780,4	6,9764	0,03200	3777,0	6,9555	0,03076	3773,6	6,9353	0,02961	3770,2	6,9157
680	0,03377	3805,3	7,0026	0,03241	3802,0	6,9818	0,03116	3798,7	6,9617	0,03000	3795,4	6,9422
690	0,03419	3830,1	7,0286	0,03282	3826,9	7,0079	0,03155	3823,8	6,9879	0,03038	3820,6	6,9685
700	0,03461	3855,0	7,0542	0,03323	3851,9	7,0336	0,03195	3848,8	7,0137	0,03076	3845,7	6,9944
710	0,03503	3879,8	7,0796	0,03363	3876,8	7,0591	0,03234	3873,8	7,0393	0,03114	3870,8	7,0201
720	0,03544	3904,6	7,1047	0,03403	3901,7	7,0843	0,03273	3898,8	7,0646	0,03151	3895,8	7,0455
730	0,03586	3929,4	7,1296	0,03443	3926,6	7,1092	0,03311	3923,7	7,0896	0,03189	3920,9	7,0705
740	0,03627	3954,2	7,1541	0,03483	3951,4	7,1339	0,03350	3948,7	7,1143	0,03226	3945,9	7,0954
750	0,03668	3979,0	7,1785	0,03523	3976,3	7,1583	0,03388	3973,6	7,1388	0,03264	3970,9	7,1200
760	0,03709	4003,8	7,2026	0,03563	4001,2	7,1825	0,03427	3998,6	7,1631	0,03301	3995,9	7,1443
770	0,03750	4028,6	7,2265	0,03602	4026,0	7,2065	0,03465	4023,5	7,1871	0,03338	4021,0	7,1684
780	0,03791	4053,4	7,2502	0,03641	4050,9	7,2302	0,03503	4048,4	7,2109	0,03374	4046,0	7,1922
790	0,03832	4078,2	7,2737	0,03681	4075,8	7,2537	0,03541	4073,4	7,2345	0,03411	4071,0	7,2159
800	0,03872	4103,1	7,2969	0,03720	4100,7	7,2771	0,03579	4098,4	7,2579	0,03448	4096,0	7,2393

3-jadval (davomi)

t	p = 14,5 MPa $t_g = 339,45$			p = 15,0 MPa $t_g = 342,16$			p = 16,0 MPa $t_g = 347,36$			p = 17,0 MPa $t_g = 352,29$		
	$v'' =$ 0,01090	$i'' =$ 2624,8	$s'' =$ 5,3422	$v'' =$ 0,01034	$i'' =$ 2610,9	$s'' =$ 5,3108	$v'' =$ 0,009308	$i'' =$ 2580,8	$s'' =$ 5,2463	$v'' =$ 0,008370	$i'' =$ 2547,4	$s'' =$ 5,1785
	v	i	s	v	i	s	v	i	s	v	i	s
0	0,0009930	14,6	0,0004	0,0009928	15,1	0,0004	0,0009923	16,1	0,0005	0,0009918	17,1	0,0005
10	0,0009936	56,0	0,1496	0,0009933	56,5	0,1495	0,0009929	57,5	0,1494	0,0009924	58,4	0,1493
20	0,0009953	97,5	0,2934	0,0009951	97,9	0,2932	0,0009947	98,9	0,2930	0,0009942	99,8	0,2928
30	0,0009980	138,9	0,4323	0,0009978	139,4	0,4322	0,0009974	140,3	0,4318	0,0009970	141,2	0,4315
40	0,0010016	180,3	0,5668	0,0010014	180,8	0,5666	0,0010009	181,7	0,5662	0,0010005	182,5	0,5658
50	0,0010058	221,8	0,6971	0,0010056	222,2	0,6969	0,0010052	223,1	0,6964	0,0010048	223,9	0,6960
60	0,0010107	263,3	0,8236	0,0010105	263,7	0,8233	0,0010101	264,5	0,8228	0,0010096	265,4	0,8223
70	0,0010162	304,8	0,9465	0,0010160	305,2	0,9462	0,0010156	306,1	0,9456	0,0010151	306,9	0,9450
80	0,0010224	346,5	1,0660	0,0010221	346,9	1,0657	0,0010217	347,6	1,0650	0,0010212	348,4	1,0644
90	0,0010290	388,1	1,1824	0,0010288	388,5	1,1821	0,0010283	389,3	1,1814	0,0010279	390,1	1,1807
100	0,0010363	429,9	1,2960	0,0010361	430,3	1,2956	0,0010356	431,1	1,2948	0,0010351	431,8	1,2941
110	0,0010441	471,9	1,4068	0,0010439	472,2	1,4064	0,0010434	473,0	1,4056	0,0010429	473,7	1,4048
120	0,0010525	513,9	1,5151	0,0010523	514,2	1,5147	0,0010517	515,0	1,5138	0,0010512	515,7	1,5129
130	0,0010615	556,1	1,6211	0,0010612	556,4	1,6206	0,0010607	557,1	1,6197	0,0010601	557,8	1,6188

t	p = 14,5 MPa t _s = 339,45			p = 15,0 MPa t _s = 342,16			p = 16,0 MPa t _s = 347,36			p = 17,0 MPa t _s = 352,29		
	v ⁻ = 0,01090	i ⁻ = 2624,8	s ⁻ = 5,3422	v ⁻ = 0,01034	i ⁻ = 2610,9	s ⁻ = 5,3108	v ⁻ = 0,009308	i ⁻ = 2580,8	s ⁻ = 5,2463	v ⁻ = 0,008370	i ⁻ = 2547,4	s ⁻ = 5,1785
	v	i	s	v	i	s	v	i	s	v	i	s
140	0,0010711	598,5	1,7249	0,0010708	598,8	1,7244	0,0010702	599,5	1,7234	0,0010696	600,1	1,7224
150	0,0010814	641,0	1,8267	0,0010810	641,3	1,8262	0,0010804	642,0	1,8251	0,0010798	642,6	1,8241
160	0,0010923	683,8	1,9266	0,0010920	684,1	1,9261	0,0010913	684,7	1,9250	0,0010906	685,3	1,9238
170	0,0011040	726,9	2,0249	0,0011036	727,1	2,0243	0,0011029	727,7	2,0231	0,0011022	728,3	2,0219
180	0,0011164	770,2	2,1216	0,0011160	770,5	2,1209	0,0011152	771,0	2,1197	0,0011145	771,5	2,1184
190	0,0011297	813,9	2,2169	0,0011293	814,1	2,2162	0,0011284	814,6	2,2148	0,0011276	815,1	2,2135
200	0,0011440	857,9	2,3110	0,0011435	858,1	2,3102	0,0011426	858,6	2,3088	0,0011417	859,0	2,3073
210	0,0011592	902,4	2,4040	0,0011587	902,6	2,4032	0,0011577	903,0	2,4016	0,0011567	903,4	2,4000
220	0,0011757	947,3	2,4961	0,0011751	947,5	2,4952	0,0011740	947,8	2,4935	0,0011729	948,2	2,4918
230	0,0011935	992,9	2,5875	0,0011929	993,0	2,5865	0,0011916	993,3	2,5847	0,0011904	993,5	2,5829
240	0,0012128	1039,0	2,6784	0,0012121	1039,1	2,6774	0,0012107	1039,3	2,6754	0,0012093	1039,5	2,6734
250	0,0012338	1086,0	2,7690	0,0012330	1086,0	2,7679	0,0012314	1086,1	2,7657	0,0012299	1086,2	2,7635
260	0,0012569	1133,8	2,8596	0,0012560	1133,8	2,8584	0,0012542	1133,8	2,8560	0,0012524	1133,8	2,8536
270	0,0012824	1182,8	2,9505	0,0012813	1182,7	2,9491	0,0012793	1182,5	2,9465	0,0012772	1182,4	2,9439
280	0,0013109	1233,0	3,0421	0,0013096	1232,8	3,0406	0,0013072	1232,5	3,0376	0,0013048	1232,1	3,0346
290	0,0013431	1284,7	3,1348	0,0013416	1284,5	3,1331	0,0013387	1283,9	3,1297	0,0013358	1283,4	3,1264
300	0,0013801	1338,5	3,2295	0,0013783	1338,1	3,2275	0,0013746	1337,2	3,2236	0,0013711	1336,4	3,2197
310	0,0014236	1394,9	3,3270	0,0014212	1394,2	3,3246	0,0014166	1392,9	3,3200	0,0014122	1391,7	3,3154
320	0,0014765	1454,8	3,4289	0,0014733	1453,8	3,4260	0,0014671	1451,9	3,4203	0,0014612	1450,1	3,4148
330	0,0015440	1520,2	3,5381	0,0015394	1518,6	3,5343	0,0015305	1515,7	3,5269	0,0015221	1513,0	3,5198
340	0,01099	2631,3	5,3528	0,0016311	1592,3	3,6553	0,0016163	1587,3	3,6445	0,0016030	1582,8	3,6346
350	0,01234	2724,4	5,5034	0,01148	2693,0	5,4435	0,009766	2617,0	5,3045	0,0017270	1666,6	3,7701
355	0,01289	2760,9	5,5619	0,01206	2733,7	5,5086	0,01047	2671,3	5,3913	0,00887	2590,5	5,2473
360	0,01339	2793,7	5,6138	0,01258	2769,6	5,5654	0,01106	2715,6	5,4616	0,00960	2650,9	5,3431
365	0,01384	2823,6	5,6609	0,01306	2801,8	5,6162	0,01158	2754,0	5,5220	0,01020	2698,8	5,4185
370	0,01427	2851,3	5,7042	0,01349	2831,4	5,6624	0,01205	2788,3	5,5755	0,01071	2739,8	5,4823
375	0,01467	2877,3	5,7443	0,01390	2858,9	5,7049	0,01248	2819,5	5,6238	0,01117	2775,9	5,5384
380	0,01505	2901,7	5,7819	0,01429	2884,6	5,7445	0,01288	2848,3	5,6680	0,01160	2808,7	5,5887
385	0,01542	2925,0	5,8174	0,01466	2908,9	5,7816	0,01326	2875,2	5,7091	0,01199	2838,7	5,6345
390	0,01577	2947,2	5,8510	0,01501	2932,1	5,8166	0,01361	2900,5	5,7474	0,01236	2866,7	5,6768
395	0,01611	2968,5	5,8830	0,01535	2954,3	5,8499	0,01395	2924,5	5,7835	0,01271	2892,9	5,7163
400	0,01643	2989,1	5,9136	0,01567	2975,5	5,8817	0,01428	2947,5	5,8177	0,01304	2917,8	5,7533
405	0,01675	3008,9	5,9430	0,01599	2996,1	5,9120	0,01460	2969,4	5,8503	0,01335	2941,4	5,7884
410	0,01705	3028,2	5,9713	0,01629	3015,9	5,9412	0,01490	2990,6	5,8814	0,01366	2964,1	5,8217
415	0,01735	3046,9	5,9987	0,01659	3035,2	5,9693	0,01519	3011,1	5,9112	0,01395	2985,9	5,8534
420	0,01764	3065,1	6,0251	0,01688	3053,9	5,9965	0,01548	3030,9	5,9399	0,01424	3006,9	5,8838
425	0,01793	3082,9	6,0507	0,01716	3072,2	6,0227	0,01576	3050,1	5,9675	0,01451	3027,2	5,9131
430	0,01820	3100,4	6,0755	0,01743	3090,0	6,0482	0,01603	3068,9	5,9943	0,01478	3046,9	5,9412
435	0,01848	3117,4	6,0997	0,01770	3107,5	6,0729	0,01629	3087,1	6,0202	0,01504	3066,1	5,9684
440	0,01874	3134,2	6,1233	0,01796	3124,6	6,0970	0,01655	3105,0	6,0453	0,01529	3084,8	5,9947
445	0,01901	3150,6	6,1462	0,01822	3141,4	6,1204	0,01680	3122,5	6,0697	0,01554	3103,0	6,0202
450	0,01926	3166,8	6,1687	0,01848	3157,8	6,1433	0,01705	3139,6	6,0935	0,01578	3120,9	6,0449
460	0,01977	3198,4	6,2121	0,01897	3190,0	6,1875	0,01753	3173,0	6,1393	0,01626	3155,5	6,0925

t	p = 14,5 MPa $t_s = 339,45$			p = 15,0 MPa $t_s = 342,16$			p = 16,0 MPa $t_s = 347,36$			p = 17,0 MPa $t_s = 352,29$		
	$v^* =$ 0,01090	$i^* =$ 2624,8	$s^* =$ 5,3422	$v^* =$ 0,01034	$i^* =$ 2610,9	$s^* =$ 5,3108	$v^* =$ 0,009308	$i^* =$ 2580,8	$s^* =$ 5,2463	$v^* =$ 0,008370	$i^* =$ 2547,4	$s^* =$ 5,1785
	v	i	s	v	i	s	v	i	s	v	i	s
470	0,02026	3229,2	6,2538	0,01946	3221,3	6,2298	0,01800	3205,3	6,1831	0,01671	3189,0	6,1378
480	0,02074	3259,2	6,2939	0,01992	3251,8	6,2706	0,01845	3236,7	6,2251	0,01715	3221,3	6,1811
490	0,02120	3288,6	6,3327	0,02038	3281,6	6,3099	0,01889	3267,3	6,2655	0,01758	3252,9	6,2227
500	0,02166	3317,5	6,3703	0,02083	3310,8	6,3479	0,01932	3297,3	6,3045	0,01799	3283,6	6,2627
510	0,02211	3345,8	6,4068	0,02127	3339,5	6,3848	0,01974	3326,7	6,3423	0,01840	3313,7	6,3014
520	0,02254	3373,8	6,4422	0,02170	3367,8	6,4207	0,02016	3355,6	6,3790	0,01880	3343,2	6,3389
530	0,02298	3401,4	6,4768	0,02212	3395,7	6,4556	0,02056	3384,1	6,4146	0,01919	3372,3	6,3752
540	0,02340	3428,7	6,5106	0,02254	3423,2	6,4897	0,02096	3412,1	6,4494	0,01957	3400,9	6,4106
550	0,02382	3455,7	6,5436	0,02295	3450,5	6,5230	0,02135	3439,8	6,4832	0,01995	3429,1	6,4451
560	0,02424	3482,5	6,5760	0,02335	3477,5	6,5556	0,02174	3467,3	6,5164	0,02032	3457,0	6,4788
570	0,02465	3509,1	6,6076	0,02375	3504,2	6,5875	0,02212	3494,4	6,5488	0,02068	3484,6	6,5117
580	0,02505	3535,4	6,6387	0,02414	3530,8	6,6188	0,02250	3521,4	6,5805	0,02104	3511,9	6,5439
590	0,02545	3561,6	6,6692	0,02453	3557,1	6,6496	0,02287	3548,1	6,6117	0,02140	3539,0	6,5755
600	0,02585	3587,6	6,6992	0,02492	3583,3	6,6797	0,02324	3574,6	6,6422	0,02175	3565,9	6,6064
610	0,02624	3613,5	6,7287	0,02530	3609,4	6,7094	0,02360	3601,0	6,6722	0,02210	3592,5	6,6368
620	0,02663	3639,3	6,7577	0,02568	3635,3	6,7386	0,02396	3627,2	6,7018	0,02244	3619,1	6,6667
630	0,02702	3665,0	6,7863	0,02606	3661,1	6,7673	0,02432	3653,3	6,7308	0,02278	3645,4	6,6961
640	0,02740	3690,5	6,8145	0,02643	3686,8	6,7956	0,02467	3679,2	6,7594	0,02312	3671,7	6,7249
650	0,02778	3716,0	6,8422	0,02680	3712,4	6,8235	0,02503	3705,1	6,7876	0,02346	3697,8	6,7534
660	0,02816	3741,5	6,8696	0,02717	3737,9	6,8510	0,02537	3730,9	6,8153	0,02379	3723,8	6,7814
670	0,02854	3766,8	6,8967	0,02754	3763,4	6,8782	0,02572	3756,6	6,8427	0,02412	3749,7	6,8090
680	0,02891	3792,1	6,9233	0,02790	3788,8	6,9050	0,02607	3782,2	6,8697	0,02445	3775,6	6,8363
690	0,02928	3817,4	6,9497	0,02826	3814,2	6,9314	0,02641	3807,8	6,8964	0,02477	3801,3	6,8632
700	0,02965	3842,6	6,9757	0,02862	3839,5	6,9576	0,02675	3833,3	6,9228	0,02510	3827,0	6,8897
710	0,03002	3867,8	7,0015	0,02898	3864,8	6,9834	0,02709	3858,7	6,9488	0,02542	3852,7	6,9159
720	0,03039	3892,9	7,0269	0,02933	3890,0	7,0090	0,02742	3884,1	6,9745	0,02574	3878,2	6,9418
730	0,03075	3918,0	7,0521	0,02968	3915,2	7,0342	0,02776	3909,5	6,9999	0,02605	3903,8	6,9674
740	0,03111	3943,2	7,0770	0,03004	3940,4	7,0592	0,02809	3934,9	7,0251	0,02637	3929,3	6,9927
750	0,03147	3968,3	7,1017	0,03039	3965,6	7,0839	0,02842	3960,2	7,0499	0,02668	3954,8	7,0178
760	0,03183	3993,3	7,1261	0,03074	3990,7	7,1084	0,02875	3985,5	7,0746	0,02700	3980,2	7,0425
770	0,03219	4018,4	7,1502	0,03108	4015,9	7,1326	0,02908	4010,8	7,0989	0,02731	4005,7	7,0670
780	0,03255	4043,5	7,1742	0,03143	4041,0	7,1566	0,02941	4036,1	7,1231	0,02762	4031,1	7,0913
790	0,03290	4068,6	7,1979	0,03177	4066,2	7,1804	0,02973	4061,3	7,1469	0,02793	4056,5	7,1153
800	0,03326	4093,7	7,2214	0,03212	4091,3	7,2039	0,03006	4086,6	7,1706	0,02824	4081,9	7,1391

3-jadval (davomi)

t	p = 18,0 MPa $t_s = 356,99$			p = 19,0 MPa $t_s = 361,47$			p = 20,0 MPa $t_s = 365,75$			p = 21,0 MPa $t_s = 369,83$		
	$v^* =$ 0,007499	$i^* =$ 2509,5	$s^* =$ 5,1055	$v^* =$ 0,006673	$i^* =$ 2465,4	$s^* =$ 5,0246	$v^* =$ 0,005859	$i^* =$ 2411,4	$s^* =$ 4,9300	$v^* =$ 0,004988	$i^* =$ 2337,6	$s^* =$ 4,8063
	v	i	s	v	i	s	v	i	s	v	i	s
0	0,0009913	18,1	0,0005	0,0009908	19,0	0,0005	0,0009904	20,0	0,0005	0,0009899	21,0	0,0005

t	p = 18,0 МПа t _с = 356,99			p = 19,0 МПа t _с = 361,47			p = 20,0 МПа t _с = 365,75			p = 21,0 МПа t _с = 369,83		
	v ^в = 0,007499	i ^в = 2509,5	s ^в = 5,1055	v ^в = 0,006673	i ^в = 2465,4	s ^в = 5,0246	v ^в = 0,005859	i ^в = 2411,4	s ^в = 4,9300	v ^в = 0,004988	i ^в = 2337,6	s ^в = 4,8063
	v	i	s	v	i	s	v	i	s	v	i	s
10	0,0009920	59,4	0,1491	0,0009915	60,4	0,1490	0,0009911	61,3	0,1489	0,0009906	62,3	0,1487
20	0,0009938	100,7	0,2926	0,0009934	101,6	0,2923	0,0009929	102,6	0,2921	0,0009925	103,5	0,2919
30	0,0009965	142,1	0,4312	0,0009961	143,0	0,4309	0,0009957	143,9	0,4306	0,0009953	144,8	0,4303
40	0,0010001	183,4	0,5654	0,0009997	184,3	0,5650	0,0009992	185,2	0,5646	0,0009988	186,0	0,5643
50	0,0010043	224,8	0,6955	0,0010039	225,7	0,6951	0,0010035	226,5	0,6946	0,0010031	227,4	0,6941
60	0,0010092	266,2	0,8218	0,0010088	267,1	0,8212	0,0010084	267,9	0,8207	0,0010079	268,7	0,8202
70	0,0010147	307,7	0,9444	0,0010143	308,5	0,9439	0,0010138	309,3	0,9433	0,0010134	310,1	0,9427
80	0,0010208	349,2	1,0638	0,0010203	350,0	1,0631	0,0010199	350,8	1,0625	0,0010195	351,6	1,0619
90	0,0010274	390,9	1,1800	0,0010270	391,6	1,1793	0,0010265	392,4	1,1786	0,0010260	393,2	1,1779
100	0,0010346	432,6	1,2933	0,0010341	433,3	1,2926	0,0010337	434,1	1,2918	0,0010332	434,9	1,2911
110	0,0010424	474,4	1,4040	0,0010419	475,2	1,4032	0,0010414	475,9	1,4024	0,0010409	476,6	1,4016
120	0,0010507	516,4	1,5121	0,0010502	517,1	1,5112	0,0010498	517,8	1,5104	0,0010493	518,5	1,5095
130	0,0010596	558,5	1,6178	0,0010590	559,2	1,6169	0,0010585	559,9	1,6160	0,0010579	560,6	1,6151
140	0,0010691	600,8	1,7214	0,0010685	601,4	1,7205	0,0010679	602,1	1,7195	0,0010673	602,8	1,7185
150	0,0010792	643,2	1,8230	0,0010786	643,9	1,8220	0,0010779	644,5	1,8209	0,0010773	645,2	1,8199
160	0,0010900	685,9	1,9227	0,0010893	686,5	1,9216	0,0010886	687,2	1,9205	0,0010880	687,8	1,9194
170	0,0011015	728,9	2,0207	0,0011007	729,4	2,0195	0,0011000	730,0	2,0183	0,0010993	730,6	2,0172
180	0,0011137	772,1	2,1171	0,0011129	772,6	2,1159	0,0011121	773,2	2,1146	0,0011114	773,7	2,1133
190	0,0011268	815,6	2,2121	0,0011260	816,1	2,2108	0,0011251	816,6	2,2094	0,0011243	817,1	2,2081
200	0,0011408	859,5	2,3058	0,0011399	859,9	2,3044	0,0011390	860,4	2,3030	0,0011381	860,9	2,3015
210	0,0011558	903,8	2,3985	0,0011548	904,2	2,3969	0,0011538	904,6	2,3954	0,0011528	905,0	2,3939
220	0,0011718	948,5	2,4902	0,0011708	948,9	2,4885	0,0011697	949,2	2,4868	0,0011686	949,6	2,4852
230	0,0011892	993,8	2,5811	0,0011880	994,1	2,5793	0,0011868	994,4	2,5775	0,0011856	994,7	2,5757
240	0,0012080	1039,7	2,6714	0,0012066	1039,9	2,6695	0,0012053	1040,1	2,6675	0,0012040	1040,4	2,6656
250	0,0012284	1086,3	2,7614	0,0012269	1086,5	2,7593	0,0012254	1086,6	2,7572	0,0012239	1086,7	2,7551
260	0,0012507	1133,8	2,8513	0,0012489	1133,8	2,8489	0,0012472	1133,8	2,8466	0,0012456	1133,9	2,8444
270	0,0012752	1182,2	2,9413	0,0012732	1182,1	2,9387	0,0012713	1182,0	2,9362	0,0012693	1181,9	2,9337
280	0,0013024	1231,8	3,0317	0,0013001	1231,6	3,0289	0,0012978	1231,3	3,0261	0,0012956	1231,0	3,0233
290	0,0013330	1282,8	3,1231	0,0013302	1282,4	3,1199	0,0013275	1281,9	3,1167	0,0013249	1281,5	3,1136
300	0,0013677	1335,6	3,2160	0,0013643	1334,8	3,2123	0,0013611	1334,1	3,2087	0,0013579	1333,5	3,2051
310	0,0014079	1390,6	3,3110	0,0014037	1389,5	3,3067	0,0013997	1388,4	3,3025	0,0013957	1387,4	3,2984
320	0,0014556	1448,4	3,4095	0,0014501	1446,8	3,4043	0,0014449	1445,3	3,3993	0,0014399	1443,9	3,3944
330	0,0015143	1510,4	3,5131	0,0015068	1508,0	3,5066	0,0014998	1505,8	3,5004	0,0014930	1503,7	3,4944
340	0,0015908	1578,7	3,6253	0,0015797	1575,0	3,6167	0,0015693	1571,5	3,6085	0,0015596	1568,3	3,6007
350	0,0017030	1658,7	3,7546	0,0016826	1651,9	3,7410	0,0016649	1646,0	3,7288	0,0016491	1640,7	3,7177
355	0,0017907	1708,3	3,8340	0,0017572	1697,7	3,8143	0,0017314	1689,1	3,7978	0,0017095	1681,8	3,7834
360	0,008110	2566,0	5,1950	0,0018733	1755,1	3,9053	0,0018247	1740,1	3,8787	0,0017889	1728,8	3,8579
365	0,008856	2632,4	5,2994	0,007463	2544,4	5,1487	0,0019933	1811,4	3,9908	0,0019103	1787,4	3,9501
370	0,009451	2683,7	5,3795	0,008218	2616,0	5,2606	0,006924	2526,5	5,1095	0,005099	2351,6	4,8280
375	0,009963	2726,9	5,4465	0,008810	2670,4	5,3448	0,007675	2602,4	5,2272	0,006482	2513,1	5,0785
380	0,01042	2764,9	5,5048	0,009314	2715,7	5,4145	0,008258	2659,2	5,3144	0,007216	2591,7	5,1993
385	0,01083	2799,0	5,5569	0,009762	2755,3	5,4748	0,008753	2706,3	5,3863	0,007784	2650,3	5,2886
390	0,01122	2830,2	5,6041	0,01017	2790,7	5,5283	0,009190	2747,2	5,4482	0,008266	2698,7	5,3619

t	p = 18,0 МПа t _с = 356,99			p = 19,0 МПа t _с = 361,47			p = 20,0 МПа t _с = 365,75			p = 21,0 МПа t _с = 369,83		
	v ⁻ 0,007499	i ⁻ 2509,5	s ⁻ 5,1055	v ⁻ 0,006673	i ⁻ 2465,4	s ⁻ 5,0246	v ⁻ 0,005859	i ⁻ 2411,4	s ⁻ 4,9300	v ⁻ 0,004988	i ⁻ 2337,6	s ⁻ 4,8063
	v	i	s	v	i	s	v	i	s	v	i	s
395	0,01158	2859,2	5,6476	0,01054	2822,9	5,5768	0,009585	2783,7	5,5030	0,008691	2740,7	5,4250
400	0,01191	2886,3	5,6881	0,01089	2852,8	5,6213	0,00995	2816,8	5,5525	0,00908	2778,0	5,4807
405	0,01224	2911,9	5,7260	0,01122	2880,7	5,6626	0,01029	2847,5	5,5978	0,00943	2812,0	5,5309
410	0,01254	2936,3	5,7618	0,01153	2907,0	5,7013	0,01061	2876,1	5,6398	0,00976	2843,3	5,5769
415	0,01284	2959,5	5,7957	0,01183	2932,0	5,7377	0,01091	2903,0	5,6791	0,01007	2872,5	5,6195
420	0,01312	2981,9	5,8281	0,01212	2955,8	5,7722	0,01120	2928,5	5,7160	0,01036	2899,9	5,6593
425	0,01340	3003,4	5,8590	0,01239	2978,7	5,8051	0,01148	2952,9	5,7510	0,01064	2925,9	5,6967
430	0,01366	3024,2	5,8887	0,01266	3000,6	5,8365	0,01174	2976,2	5,7843	0,01091	2950,7	5,7321
435	0,01392	3044,4	5,9173	0,01291	3021,9	5,8666	0,01200	2998,6	5,8161	0,01116	2974,5	5,7657
440	0,01417	3064,0	5,9448	0,01316	3042,5	5,8955	0,01225	3020,3	5,8466	0,01141	2997,3	5,7978
445	0,01442	3083,0	5,9715	0,01340	3062,4	5,9234	0,01249	3041,2	5,8759	0,01165	3019,3	5,8286
450	0,01465	3101,7	5,9973	0,01364	3081,9	5,9504	0,01272	3061,5	5,9041	0,01188	3040,6	5,8581
460	0,01512	3137,7	6,0468	0,01409	3119,3	6,0019	0,01317	3100,6	5,9577	0,01233	3081,3	5,9140
470	0,01556	3172,3	6,0936	0,01453	3155,2	6,0504	0,01360	3137,8	6,0081	0,01275	3119,9	5,9664
480	0,01599	3205,7	6,1383	0,01495	3189,7	6,0966	0,01401	3173,4	6,0558	0,01316	3156,8	6,0157
490	0,01641	3238,1	6,1811	0,01536	3223,1	6,1406	0,01441	3207,9	6,1012	0,01355	3192,3	6,0625
500	0,01681	3269,7	6,2222	0,01575	3255,6	6,1829	0,01479	3241,2	6,1445	0,01393	3226,6	6,1071
510	0,01720	3300,5	6,2618	0,01613	3287,2	6,2235	0,01517	3273,6	6,1862	0,01429	3259,8	6,1498
520	0,01759	3330,7	6,3002	0,01651	3318,1	6,2627	0,01553	3305,2	6,2263	0,01465	3292,2	6,1909
530	0,01797	3360,4	6,3373	0,01687	3348,3	6,3006	0,01588	3336,1	6,2650	0,01499	3323,8	6,2305
540	0,01833	3389,5	6,3734	0,01723	3378,1	6,3374	0,01623	3366,4	6,3026	0,01533	3354,7	6,2687
550	0,01870	3418,3	6,4085	0,01758	3407,3	6,3732	0,01657	3396,2	6,3390	0,01566	3385,1	6,3058
560	0,01905	3446,6	6,4427	0,01792	3436,1	6,4080	0,01690	3425,6	6,3744	0,01598	3414,9	6,3419
570	0,01941	3474,6	6,4762	0,01826	3464,6	6,4419	0,01723	3454,5	6,4089	0,01630	3444,3	6,3769
580	0,01975	3502,4	6,5089	0,01860	3492,7	6,4751	0,01755	3483,0	6,4426	0,01661	3473,3	6,4111
590	0,02009	3529,8	6,5408	0,01892	3520,6	6,5076	0,01787	3511,3	6,4755	0,01692	3501,9	6,4445
600	0,02043	3557,0	6,5722	0,01925	3548,2	6,5393	0,01818	3539,2	6,5077	0,01722	3530,2	6,4771
610	0,02076	3584,1	6,6030	0,01957	3575,5	6,5705	0,01849	3566,9	6,5392	0,01752	3558,3	6,5090
620	0,02109	3610,9	6,6332	0,01989	3602,6	6,6010	0,01880	3594,4	6,5701	0,01781	3586,0	6,5403
630	0,02142	3637,5	6,6629	0,02020	3629,6	6,6310	0,01910	3621,6	6,6005	0,01811	3613,6	6,5710
640	0,02174	3664,0	6,6920	0,02051	3656,4	6,6605	0,01940	3648,7	6,6303	0,01839	3641,0	6,6011
650	0,02206	3690,4	6,7208	0,02082	3683,0	6,6895	0,01969	3675,6	6,6596	0,01868	3668,1	6,6307
660	0,02238	3716,7	6,7491	0,02112	3709,5	6,7181	0,01999	3702,3	6,6884	0,01896	3695,1	6,6598
670	0,02270	3742,8	6,7769	0,02142	3735,9	6,7462	0,02028	3729,0	6,7168	0,01924	3722,0	6,6884
680	0,02301	3768,9	6,8044	0,02172	3762,2	6,7739	0,02056	3755,5	6,7447	0,01952	3748,7	6,7166
690	0,02332	3794,8	6,8315	0,02202	3788,4	6,8013	0,02085	3781,9	6,7723	0,01979	3775,3	6,7444
700	0,02363	3820,7	6,8583	0,02231	3814,5	6,8282	0,02113	3808,2	6,7994	0,02006	3801,8	6,7718
710	0,02393	3846,6	6,8847	0,02261	3840,5	6,8548	0,02141	3834,4	6,8262	0,02033	3828,2	6,7988
720	0,02424	3872,3	6,9107	0,02290	3866,4	6,8811	0,02169	3860,5	6,8527	0,02060	3854,6	6,8254
730	0,02454	3898,1	6,9365	0,02319	3892,3	6,9070	0,02197	3886,6	6,8788	0,02087	3880,8	6,8517
740	0,02484	3923,7	6,9620	0,02348	3918,2	6,9326	0,02225	3912,6	6,9046	0,02113	3907,0	6,8776
750	0,02514	3949,4	6,9872	0,02376	3944,0	6,9580	0,02252	3938,5	6,9301	0,02140	3933,1	6,9033
760	0,02544	3975,0	7,0121	0,02405	3969,7	6,9830	0,02279	3964,4	6,9553	0,02166	3959,1	6,9286

t	p = 18,0 MPa t _p = 356,99			p = 19,0 MPa t _p = 361,47			p = 20,0 MPa t _p = 365,75			p = 21,0 MPa t _p = 369,83		
	v [*] = 0,007499	i [*] = 2509,5	s [*] = 5,1055	v [*] = 0,006673	i [*] = 2465,4	s [*] = 5,0246	v [*] = 0,005859	i [*] = 2411,4	s [*] = 4,9300	v [*] = 0,004988	i [*] = 2337,6	s [*] = 4,8063
	v	i	s	v	i	s	v	i	s	v	i	s
770	0,02574	4000,6	7,0367	0,02433	3995,4	7,0078	0,02306	3990,3	6,9802	0,02192	3985,2	6,9537
780	0,02603	4026,1	7,0611	0,02461	4021,1	7,0323	0,02333	4016,1	7,0048	0,02218	4011,1	6,9785
790	0,02633	4051,7	7,0852	0,02489	4046,8	7,0566	0,02360	4041,9	7,0292	0,02243	4037,1	7,0030
800	0,02662	4077,2	7,1091	0,02517	4072,5	7,0806	0,02387	4067,7	7,0534	0,02269	4063,0	7,0273

3-jadval (davomi)

t	p = 22,0 MPa t _p = 373,71			p = 23,0 MPa			p = 24,0 MPa			p = 25,0 MPa		
	v [*] = 0,003609	i [*] = 2169,2	s [*] = 4,5386	-			-			-		
	v	i	s	v	i	s	v	i	s	v	i	s
0	0,0009894	22,0	0,0005	0,0009889	23,0	0,0004	0,0009885	24,0	0,0004	0,0009880	25,0	0,0004
10	0,0009902	63,2	0,1486	0,0009897	64,2	0,1485	0,0009893	65,1	0,1483	0,0009888	66,1	0,1482
20	0,0009921	104,4	0,2916	0,0009916	105,3	0,2914	0,0009912	106,3	0,2911	0,0009908	107,2	0,2909
30	0,0009948	145,7	0,4299	0,0009944	146,6	0,4296	0,0009940	147,4	0,4293	0,0009936	148,3	0,4290
40	0,0009984	186,9	0,5639	0,0009980	187,8	0,5635	0,0009976	188,7	0,5631	0,0009972	189,5	0,5627
50	0,0010026	228,2	0,6937	0,0010022	229,1	0,6932	0,0010018	229,9	0,6928	0,0010014	230,8	0,6923
60	0,0010075	269,6	0,8197	0,0010071	270,4	0,8192	0,0010067	271,2	0,8187	0,0010063	272,1	0,8181
70	0,0010130	311,0	0,9421	0,0010126	311,8	0,9415	0,0010121	312,6	0,9410	0,0010117	313,4	0,9404
80	0,0010190	352,4	1,0612	0,0010186	353,2	1,0606	0,0010181	354,0	1,0600	0,0010177	354,8	1,0593
90	0,0010256	394,0	1,1772	0,0010251	394,7	1,1766	0,0010247	395,5	1,1759	0,0010242	396,3	1,1752
100	0,0010327	435,6	1,2904	0,0010322	436,4	1,2896	0,0010318	437,1	1,2889	0,0010313	437,9	1,2881
110	0,0010404	477,4	1,4008	0,0010399	478,1	1,4000	0,0010394	478,8	1,3992	0,0010389	479,6	1,3984
120	0,0010486	519,2	1,5087	0,0010481	520,0	1,5078	0,0010476	520,7	1,5070	0,0010471	521,4	1,5061
130	0,0010574	561,3	1,6142	0,0010568	562,0	1,6133	0,0010563	562,6	1,6124	0,0010558	563,3	1,6115
140	0,0010668	603,4	1,7175	0,0010662	604,1	1,7166	0,0010656	604,8	1,7156	0,0010651	605,4	1,7147
150	0,0010767	645,8	1,8189	0,0010761	646,4	1,8178	0,0010755	647,1	1,8168	0,0010749	647,7	1,8158
160	0,0010874	688,4	1,9183	0,0010867	689,0	1,9172	0,0010861	689,6	1,9161	0,0010854	690,2	1,9150
170	0,0010987	731,2	2,0160	0,0010980	731,8	2,0148	0,0010973	732,3	2,0137	0,0010966	732,9	2,0125
180	0,0011107	774,2	2,1121	0,0011100	774,8	2,1109	0,0011092	775,3	2,1096	0,0011085	775,9	2,1084
190	0,0011235	817,6	2,2068	0,0011227	818,1	2,2054	0,0011219	818,6	2,2041	0,0011211	819,2	2,2028
200	0,0011372	861,3	2,3001	0,0011364	861,8	2,2987	0,0011355	862,3	2,2973	0,0011346	862,7	2,2959
210	0,0011519	905,4	2,3923	0,0011509	905,8	2,3908	0,0011500	906,3	2,3893	0,0011490	906,7	2,3878*
220	0,0011676	949,9	2,4836	0,0011665	950,3	2,4819	0,0011655	950,7	2,4803	0,0011645	951,1	2,4787
230	0,0011845	995,0	2,5740	0,0011833	995,3	2,5722	0,0011822	995,6	2,5705	0,0011810	995,9	2,5688
240	0,0012027	1040,6	2,6637	0,0012014	1040,8	2,6618	0,0012001	1041,1	2,6600	0,0011989	1041,3	2,6581
250	0,0012224	1086,9	2,7530	0,0012210	1087,0	2,7510	0,0012196	1087,2	2,7490	0,0012181	1087,3	2,7469
260	0,0012439	1133,9	2,8421	0,0012423	1134,0	2,8399	0,0012407	1134,0	2,8376	0,0012391	1134,1	2,8355
270	0,0012674	1181,8	2,9312	0,0012656	1181,8	2,9287	0,0012637	1181,7	2,9263	0,0012619	1181,7	2,9239
280	0,0012934	1230,8	3,0205	0,0012912	1230,6	3,0178	0,0012891	1230,4	3,0151	0,0012870	1230,2	3,0125
290	0,0013223	1281,1	3,1105	0,0013197	1280,7	3,1075	0,0013173	1280,3	3,1045	0,0013148	1280,0	3,1016
300	0,0013548	1332,8	3,2016	0,0013518	1332,2	3,1982	0,0013488	1331,6	3,1948	0,0013459	1331,1	3,1915

t	p = 22,0 МПа $t_p = 373,71$			p = 23,0 МПа			p = 24,0 МПа			p = 25,0 МПа		
	$v^- =$ 0,003609	$i^- =$ 2169,2	$s^- =$ 4,5386	-			-			-		
	v	i	s	v	i	s	v	i	s	v	i	s
310	0,0013919	1386,4	3,2944	0,0013882	1385,5	3,2905	0,0013846	1384,7	3,2866	0,0013810	1383,8	3,2828
320	0,0014351	1442,5	3,3896	0,0014304	1441,2	3,3850	0,0014259	1439,9	3,3805	0,0014215	1438,7	3,3761
330	0,0014866	1501,7	3,4886	0,0014805	1499,8	3,4830	0,0014746	1498,0	3,4776	0,0014690	1496,3	3,4723
340	0,0015506	1565,3	3,5933	0,0015421	1562,5	3,5862	0,0015340	1559,9	3,5794	0,0015264	1557,5	3,5729
350	0,0016349	1635,9	3,7074	0,0016219	1631,6	3,6978	0,0016099	1627,6	3,6888	0,0015988	1623,9	3,6803
355	0,0016899	1675,3	3,7705	0,001673	1669,7	3,7587	0,001657	1664,5	3,7479	0,001644	1659,9	3,7379
360	0,0017602	1719,5	3,8404	0,001736	1711,6	3,8252	0,001715	1704,7	3,8116	0,001697	1698,6	3,7993
365	0,0018583	1771,6	3,9224	0,001820	1759,5	3,9006	0,001789	1749,7	3,8823	0,001763	1741,3	3,8664
370	0,0020286	1842,6	4,0333	0,001945	1818,8	3,9932	0,001891	1802,5	3,9649	0,001850	1789,9	3,9424
375	0,004899	2354,0	4,8240	0,002218	1913,8	4,1402	0,002060	1872,5	4,0731	0,001978	1849,3	4,0344
380	0,006125	2504,6	5,0556	0,004783	2364,9	4,8334	0,002612	2025,2	4,3076	0,002218	1935,7	4,1670
385	0,006829	2584,1	5,1769	0,005840	2500,6	5,0405	0,004705	2379,4	4,8483	0,003201	2160,4	4,5095
390	0,007377	2643,7	5,2671	0,006504	2579,5	5,1599	0,005613	2500,8	5,0320	0,004647	2395,5	4,8656
395	0,007843	2693,0	5,3413	0,007030	2639,5	5,2500	0,006233	2577,7	5,1477	0,005432	2504,3	5,0290
400	0,008255	2735,8	5,4050	0,007477	2689,2	5,3242	0,006731	2637,4	5,2366	0,006005	2578,6	5,1399
405	0,008627	2773,8	5,4614	0,007874	2732,5	5,3882	0,007160	2687,3	5,3105	0,006476	2637,5	5,2270
410	0,008970	2808,4	5,5121	0,008233	2771,0	5,4449	0,007540	2730,8	5,3744	0,006884	2687,1	5,2999
415	0,009288	2840,2	5,5586	0,008564	2806,0	5,4959	0,007886	2769,6	5,4310	0,007248	2730,5	5,3633
420	0,009588	2869,9	5,6015	0,008872	2838,3	5,5426	0,008205	2804,9	5,4821	0,007579	2769,4	5,4196
425	0,009872	2897,8	5,6417	0,009162	2868,3	5,5859	0,008502	2837,4	5,5289	0,007886	2804,9	5,4706
430	0,010142	2924,3	5,6794	0,009436	2896,6	5,6262	0,008781	2867,8	5,5723	0,008172	2837,7	5,5174
435	0,01040	2949,4	5,7151	0,009698	2923,4	5,6642	0,009047	2896,4	5,6128	0,008442	2868,3	5,5607
440	0,01065	2973,6	5,7491	0,009948	2949,0	5,7001	0,009299	2923,5	5,6509	0,008697	2897,1	5,6013
445	0,01089	2996,7	5,7814	0,010188	2973,4	5,7343	0,009541	2949,3	5,6870	0,008941	2924,4	5,6394
450	0,01112	3019,0	5,8124	0,01042	2996,8	5,7668	0,009774	2974,0	5,7212	0,009175	2950,4	5,6755
460	0,01156	3061,6	5,8708	0,01086	3041,3	5,8279	0,010215	3020,5	5,7852	0,009617	2999,2	5,7426
470	0,01198	3101,7	5,9252	0,01128	3083,1	5,8845	0,01063	3064,0	5,8441	0,010029	3044,5	5,8040
480	0,01238	3139,9	5,9763	0,01167	3122,7	5,9374	0,01102	3105,1	5,8990	0,01042	3087,1	5,8609
490	0,01277	3176,5	6,0246	0,01205	3160,4	5,9872	0,01139	3144,1	5,9504	0,01079	3127,4	5,9141
500	0,01314	3211,8	6,0704	0,01242	3196,7	6,0345	0,01175	3181,4	5,9991	0,01114	3165,9	5,9642
510	0,01349	3245,9	6,1143	0,01277	3231,7	6,0795	0,01210	3217,4	6,0453	0,01148	3202,8	6,0117
520	0,01384	3279,0	6,1563	0,01311	3265,7	6,1225	0,01243	3252,2	6,0894	0,01181	3238,5	6,0569
530	0,01418	3311,3	6,1968	0,01344	3298,7	6,1639	0,01275	3285,9	6,1317	0,01213	3273,0	6,1001
540	0,01451	3342,9	6,2358	0,01376	3330,9	6,2037	0,01307	3318,8	6,1723	0,01244	3306,6	6,1416
550	0,01483	3373,8	6,2736	0,01407	3362,4	6,2422	0,01338	3350,9	6,2116	0,01274	3339,3	6,1816
560	0,01514	3404,1	6,3103	0,01438	3393,3	6,2795	0,01367	3382,3	6,2496	0,01303	3371,3	6,2203
570	0,01545	3434,0	6,3459	0,01468	3423,6	6,3158	0,01397	3413,2	6,2864	0,01331	3402,7	6,2577
580	0,01576	3463,4	6,3806	0,01497	3453,5	6,3510	0,01426	3443,5	6,3222	0,01360	3433,5	6,2941
590	0,01605	3492,5	6,4145	0,01526	3483,0	6,3853	0,01454	3473,4	6,3570	0,01387	3463,8	6,3294
600	0,01635	3521,2	6,4475	0,01555	3512,1	6,4188	0,01481	3502,9	6,3910	0,01414	3493,7	6,3638
610	0,01664	3549,6	6,4798	0,01583	3540,8	6,4516	0,01509	3532,0	6,4241	0,01440	3523,2	6,3974
620	0,01692	3577,7	6,5115	0,01610	3569,3	6,4836	0,01536	3560,8	6,4565	0,01467	3552,3	6,4302
630	0,01720	3605,5	6,5425	0,01638	3597,5	6,5150	0,01562	3589,3	6,4883	0,01492	3581,1	6,4623

t	p = 22,0 МПа t _с = 373,71			p = 23,0 МПа			p = 24,0 МПа			p = 25,0 МПа		
	v' = 0,003609	i' = 2169,2	s' = 4,5386	-			-			-		
	v	i	s	v	i	s	v	i	s	v	i	s
640	0,01748	3633,2	6,5730	0,01665	3625,4	6,5457	0,01588	3617,6	6,5194	0,01518	3609,7	6,4937
650	0,01776	3660,6	6,6029	0,01691	3653,1	6,5759	0,01614	3645,6	6,5499	0,01543	3638,0	6,5246
660	0,01803	3687,9	6,6322	0,01718	3680,6	6,6056	0,01640	3673,3	6,5798	0,01568	3666,0	6,5548
670	0,01830	3715,0	6,6611	0,01744	3708,0	6,6347	0,01665	3700,9	6,6092	0,01592	3693,9	6,5845
680	0,01856	3742,0	6,6896	0,01770	3735,2	6,6634	0,01690	3728,4	6,6381	0,01616	3721,5	6,6136
690	0,01883	3768,8	6,7176	0,01795	3762,2	6,6916	0,01715	3755,6	6,6666	0,01641	3749,0	6,6423
700	0,01909	3795,5	6,7451	0,01820	3789,1	6,7195	0,01739	3782,8	6,6946	0,01664	3776,4	6,6706
710	0,01935	3822,1	6,7723	0,01846	3815,9	6,7468	0,01764	3809,8	6,7222	0,01688	3803,6	6,6984
720	0,01961	3848,6	6,7992	0,01870	3842,6	6,7739	0,01788	3836,6	6,7494	0,01711	3830,6	6,7258
730	0,01987	3875,0	6,8256	0,01895	3869,2	6,8005	0,01812	3863,4	6,7763	0,01734	3857,6	6,7528
740	0,02012	3901,4	6,8518	0,01920	3895,7	6,8268	0,01835	3890,1	6,8027	0,01758	3884,5	6,7794
750	0,02038	3927,6	6,8776	0,01944	3922,2	6,8528	0,01859	3916,7	6,8289	0,01780	3911,2	6,8057
760	0,02063	3953,8	6,9031	0,01969	3948,5	6,8784	0,01882	3943,2	6,8547	0,01803	3937,9	6,8317
770	0,02088	3980,0	6,9283	0,01993	3974,9	6,9038	0,01906	3969,7	6,8801	0,01826	3964,5	6,8573
780	0,02113	4006,1	6,9532	0,02017	4001,1	6,9288	0,01929	3996,1	6,9053	0,01848	3991,1	6,8826
790	0,02137	4032,2	6,9778	0,02040	4027,3	6,9536	0,01952	4022,4	6,9302	0,01870	4017,6	6,9077
800	0,02162	4058,2	7,0022	0,02064	4053,5	6,9781	0,01975	4048,8	6,9549	0,01892	4044,0	6,9324

3-jadval (davomi)

t	p = 26,0 МПа			p = 27,0 МПа			p = 28,0 МПа			p = 29,0 МПа		
	v	i	s	v	i	s	v	i	s	v	i	s
0	0,0009875	25,9	0,0004	0,0009871	26,9	0,0004	0,0009866	27,9	0,0003	0,0009861	28,9	0,0003
10	0,0009884	67,0	0,1480	0,0009880	68,0	0,1479	0,0009875	68,9	0,1477	0,0009871	69,8	0,1476
20	0,0009903	108,1	0,2907	0,0009899	109,0	0,2904	0,0009895	109,9	0,2902	0,0009891	110,9	0,2899
30	0,0009932	149,2	0,4287	0,0009928	150,1	0,4283	0,0009923	151,0	0,4280	0,0009919	151,9	0,4277
40	0,0009967	190,4	0,5623	0,0009963	191,3	0,5619	0,0009959	192,2	0,5615	0,0009955	193,0	0,5611
50	0,0010010	231,6	0,6919	0,0010006	232,5	0,6914	0,0010002	233,3	0,6910	0,0009997	234,2	0,6905
60	0,0010058	272,9	0,8176	0,0010054	273,7	0,8171	0,0010050	274,6	0,8166	0,0010046	275,4	0,8161
70	0,0010113	314,2	0,9398	0,0010108	315,0	0,9393	0,0010104	315,9	0,9387	0,0010100	316,7	0,9381
80	0,0010173	355,6	1,0587	0,0010168	356,4	1,0581	0,0010164	357,2	1,0575	0,0010160	358,0	1,0568
90	0,0010238	397,1	1,1745	0,0010233	397,9	1,1738	0,0010229	398,6	1,1732	0,0010224	399,4	1,1725
100	0,0010308	438,6	1,2874	0,0010304	439,4	1,2867	0,0010299	440,2	1,2859	0,0010295	440,9	1,2852
110	0,0010384	480,3	1,3976	0,0010380	481,0	1,3968	0,0010375	481,8	1,3960	0,0010370	482,5	1,3953
120	0,0010466	522,1	1,5053	0,0010461	522,8	1,5044	0,0010456	523,5	1,5036	0,0010451	524,3	1,5028
130	0,0010552	564,0	1,6106	0,0010547	564,7	1,6097	0,0010542	565,4	1,6088	0,0010537	566,1	1,6079
140	0,0010645	606,1	1,7137	0,0010639	606,8	1,7128	0,0010634	607,5	1,7118	0,0010628	608,1	1,7109
150	0,0010743	648,4	1,8148	0,0010737	649,0	1,8138	0,0010731	649,7	1,8128	0,0010726	650,3	1,8118
160	0,0010848	690,8	1,9140	0,0010842	691,5	1,9129	0,0010835	692,1	1,9118	0,0010829	692,7	1,9107
170	0,0010959	733,5	2,0114	0,0010952	734,1	2,0102	0,0010946	734,7	2,0091	0,0010939	735,3	2,0079
180	0,0011078	776,5	2,1072	0,0011070	777,0	2,1060	0,0011063	777,6	2,1047	0,0011056	778,1	2,1035
190	0,0011204	819,7	2,2015	0,0011196	820,2	2,2002	0,0011188	820,7	2,1989	0,0011180	821,2	2,1976
200	0,0011338	863,2	2,2945	0,0011329	863,7	2,2931	0,0011321	864,2	2,2918	0,0011313	864,7	2,2904

t	p = 26,0 Mfla			p = 27,0 Mfla			p = 28,0 Mfla			p = 29,0 Mfla		
	v	i	s	v	i	s	v	i	s	v	i	s
210	0,0011481	907,1	2,3863	0,0011472	907,5	2,3849	0,0011463	908,0	2,3834	0,0011454	908,4	2,3819
220	0,0011635	951,4	2,4771	0,0011624	951,8	2,4756	0,0011614	952,2	2,4740	0,0011604	952,6	2,4724
230	0,0011799	996,2	2,5671	0,0011788	996,6	2,5654	0,0011777	996,9	2,5637	0,0011766	997,2	2,5620
240	0,0011976	1041,6	2,6563	0,0011964	1041,8	2,6544	0,0011952	1042,1	2,6526	0,0011940	1042,3	2,6508
250	0,0012167	1087,5	2,7449	0,0012154	1087,7	2,7430	0,0012140	1087,9	2,7410	0,0012126	1088,1	2,7390
260	0,0012375	1134,2	2,8333	0,0012359	1134,3	2,8311	0,0012344	1134,3	2,8290	0,0012329	1134,5	2,8269
270	0,0012601	1181,6	2,9215	0,0012584	1181,6	2,9192	0,0012566	1181,6	2,9168	0,0012549	1181,6	2,9145
280	0,0012849	1230,1	3,0099	0,0012829	1229,9	3,0073	0,0012809	1229,8	3,0047	0,0012789	1229,7	3,0022
290	0,0013124	1279,6	3,0987	0,0013100	1279,3	3,0958	0,0013077	1279,0	3,0929	0,0013054	1278,8	3,0901
300	0,0013430	1330,5	3,1882	0,0013402	1330,0	3,1850	0,0013375	1329,5	3,1818	0,0013348	1329,1	3,1787
310	0,0013776	1383,1	3,2791	0,0013742	1382,3	3,2754	0,0013710	1381,6	3,2718	0,0013678	1380,9	3,2683
320	0,0014172	1437,6	3,3718	0,0014131	1436,5	3,3676	0,0014091	1435,5	3,3634	0,0014052	1434,5	3,3594
330	0,0014635	1494,7	3,4672	0,0014583	1493,1	3,4622	0,0014532	1491,7	3,4574	0,0014484	1490,3	3,4527
340	0,0015191	1555,2	3,5667	0,0015122	1553,0	3,5606	0,0015056	1550,9	3,5548	0,0014993	1548,9	3,5491
350	0,0015884	1620,4	3,6723	0,0015788	1617,2	3,6646	0,0015697	1614,3	3,6573	0,0015611	1611,4	3,6503
355	0,001631	1655,6	3,7285	0,001619	1651,6	3,7196	0,001608	1648,0	3,7112	0,001598	1644,6	3,7032
360	0,001681	1693,2	3,7880	0,001666	1688,2	3,7775	0,001652	1683,6	3,7677	0,001639	1679,5	3,7585
365	0,001741	1734,0	3,8523	0,001721	1727,5	3,8394	0,001704	1721,7	3,8277	0,001688	1716,5	3,8167
370	0,001818	1779,6	3,9234	0,001790	1770,8	3,9069	0,001766	1763,1	3,8922	0,001746	1756,3	3,8789
375	0,001922	1832,8	4,0059	0,001880	1819,9	3,9829	0,001846	1809,1	3,9635	0,001817	1800,0	3,9465
380	0,002087	1901,1	4,1107	0,002008	1878,9	4,0737	0,001952	1862,4	4,0454	0,001909	1849,2	4,0223
385	0,002446	2011,8	4,2795	0,002225	1958,7	4,1954	0,002111	1928,6	4,1463	0,002036	1907,5	4,1111
390	0,003552	2242,7	4,6290	0,002734	2096,0	4,4031	0,002398	2022,3	4,2882	0,002234	1982,0	4,2239
395	0,004602	2412,5	4,8841	0,003740	2295,1	4,7021	0,003012	2172,6	4,5138	0,002596	2088,8	4,3842
400	0,005287	2510,6	5,0304	0,004566	2429,8	4,9032	0,003855	2334,4	4,7552	0,003231	2234,3	4,6012
405	0,005814	2581,8	5,1358	0,005168	2519,0	5,0351	0,004536	2447,4	4,9225	0,003930	2367,1	4,7978
410	0,006256	2639,5	5,2206	0,005653	2587,0	5,1351	0,005071	2529,1	5,0424	0,004511	2465,1	4,9418
415	0,006643	2688,6	5,2922	0,006067	2643,2	5,2171	0,005516	2593,9	5,1370	0,004989	2540,5	5,0517
420	0,006990	2731,8	5,3548	0,006433	2691,5	5,2870	0,005904	2648,5	5,2160	0,005399	2602,2	5,1411
425	0,007308	2770,6	5,4106	0,006764	2734,3	5,3485	0,006249	2695,8	5,2841	0,005762	2655,1	5,2171
430	0,007602	2806,1	5,4612	0,007067	2772,9	5,4037	0,006563	2738,1	5,3444	0,006088	2701,4	5,2833
435	0,007877	2838,9	5,5078	0,007349	2808,3	5,4538	0,006853	2716,4	5,3987	0,006386	2743,0	5,3422
440	0,008137	2869,7	5,5510	0,007614	2841,2	5,5001	0,007123	2811,6	5,4483	0,006662	2780,8	5,3955
445	0,008384	2898,6	5,5915	0,007864	2871,9	5,5431	0,007377	2844,4	5,4940	0,006920	2815,8	5,4443
450	0,008619	2926,1	5,6296	0,008101	2901,0	5,5833	0,007617	2875,1	5,5367	0,007164	2848,4	5,4896
460	0,009062	2977,3	5,7000	0,008546	2954,8	5,6573	0,008065	2931,8	5,6145	0,007615	2908,1	5,5716
470	0,009474	3024,6	5,7640	0,008958	3004,2	5,7242	0,008477	2983,4	5,6845	0,008029	2962,1	5,6447
480	0,009861	3068,8	5,8231	0,009344	3050,1	5,7856	0,008862	3031,1	5,7483	0,008413	3011,7	5,7111
490	0,010228	3110,5	5,8781	0,009708	3093,3	5,8425	0,009224	3075,8	5,8072	0,008773	3058,0	5,7721
500	0,01058	3150,2	5,9298	0,010054	3134,2	5,8958	0,009568	3117,9	5,8621	0,009114	3101,5	5,8287
510	0,01091	3188,1	5,9785	0,01038	3173,2	5,9459	0,009895	3158,1	5,9136	0,009439	3142,7	5,8817
520	0,01124	3224,6	6,0249	0,01070	3210,6	5,9934	0,010210	3196,5	5,9624	0,009749	3182,1	5,9317
530	0,01155	3259,9	6,0691	0,01101	3246,8	6,0387	0,01051	3233,4	6,0087	0,010048	3220,0	5,9791
540	0,01185	3294,2	6,1115	0,01131	3281,8	6,0820	0,01080	3269,2	6,0529	0,01034	3256,5	6,0243
550	0,01214	3327,6	6,1523	0,01160	3315,8	6,1236	0,01109	3303,9	6,0953	0,01062	3291,9	6,0676

t	p = 26,0 MPa			p = 27,0 MPa			p = 28,0 MPa			p = 29,0 MPa		
	v	i	s	v	i	s	v	i	s	v	i	s
560	0,01243	3360,2	6,1917	0,01188	3349,0	6,1636	0,01136	3337,7	6,1361	0,01089	3326,3	6,1091
570	0,01271	3392,1	6,2297	0,01215	3381,4	6,2023	0,01163	3370,6	6,1755	0,01115	3359,8	6,1491
580	0,01298	3423,4	6,2666	0,01242	3413,2	6,2398	0,01190	3402,9	6,2136	0,01141	3392,6	6,1878
590	0,01325	3454,1	6,3025	0,01268	3444,4	6,2762	0,01215	3434,6	6,2505	0,01166	3424,8	6,2253
600	0,01352	3484,4	6,3374	0,01294	3475,1	6,3116	0,01241	3465,7	6,2863	0,01191	3456,3	6,2616
610	0,01378	3514,3	6,3714	0,01319	3505,4	6,3460	0,01265	3496,4	6,3212	0,01215	3487,4	6,2970
620	0,01403	3543,8	6,4046	0,01344	3535,2	6,3796	0,01290	3526,6	6,3552	0,01239	3518,0	6,3314
630	0,01428	3572,9	6,4371	0,01369	3564,7	6,4125	0,01314	3556,4	6,3885	0,01262	3548,1	6,3650
640	0,01453	3601,8	6,4688	0,01393	3593,9	6,4446	0,01337	3585,9	6,4209	0,01285	3577,9	6,3978
650	0,01477	3630,4	6,5000	0,01417	3622,7	6,4760	0,01360	3615,1	6,4527	0,01308	3607,4	6,4299
660	0,01502	3658,7	6,5305	0,01440	3651,3	6,5068	0,01383	3643,9	6,4838	0,01330	3636,5	6,4613
670	0,01525	3686,8	6,5604	0,01463	3679,7	6,5371	0,01406	3672,6	6,5143	0,01352	3665,4	6,4921
680	0,01549	3714,7	6,5899	0,01486	3707,8	6,5667	0,01428	3701,0	6,5442	0,01374	3694,1	6,5223
690	0,01572	3742,4	6,6188	0,01509	3735,8	6,5959	0,01450	3729,1	6,5737	0,01396	3722,5	6,5520
700	0,01595	3770,0	6,6473	0,01531	3763,6	6,6246	0,01472	3757,1	6,6026	0,01417	3750,7	6,5811
710	0,01618	3797,4	6,6753	0,01554	3791,2	6,6528	0,01494	3784,9	6,6310	0,01438	3778,7	6,6098
720	0,01641	3824,6	6,7029	0,01576	3818,6	6,6806	0,01515	3812,6	6,6590	0,01459	3806,6	6,6380
730	0,01663	3851,8	6,7301	0,01598	3846,0	6,7080	0,01536	3840,1	6,6866	0,01480	3834,3	6,6657
740	0,01686	3878,8	6,7569	0,01619	3873,2	6,7350	0,01557	3867,5	6,7137	0,01500	3861,8	6,6931
750	0,01708	3905,8	6,7833	0,01641	3900,3	6,7616	0,01578	3894,8	6,7405	0,01520	3889,3	6,7200
760	0,01730	3932,6	6,8094	0,01662	3927,3	6,7879	0,01599	3921,9	6,7669	0,01540	3916,6	6,7466
770	0,01752	3959,4	6,8352	0,01683	3954,2	6,8138	0,01620	3949,0	6,7930	0,01560	3943,8	6,7728
780	0,01773	3986,1	6,8607	0,01704	3981,0	6,8394	0,01640	3976,0	6,8188	0,01580	3971,0	6,7987
790	0,01795	4012,7	6,8858	0,01725	4007,8	6,8647	0,01660	4002,9	6,8442	0,01600	3998,0	6,8243
800	0,01816	4039,3	6,9107	0,01746	4034,5	6,8897	0,01680	4029,7	6,8693	0,01620	4025,0	6,8495

3-jadval (davomi)

t	p = 30,0 MPa			p = 31,0 MPa			p = 32,0 MPa			p = 33,0 MPa		
	v	i	s	v	i	s	v	i	s	v	i	s
0	0,0009857	29,9	0,0003	0,0009852	30,8	0,0002	0,0009847	31,8	0,0002	0,0009843	32,8	0,0002
10	0,0009866	70,8	0,1474	0,0009862	71,7	0,1473	0,0009858	72,7	0,1471	0,0009853	73,6	0,1470
20	0,0009887	111,8	0,2897	0,0009882	112,7	0,2894	0,0009878	113,6	0,2892	0,0009874	114,5	0,2889
30	0,0009915	152,8	0,4274	0,0009911	153,7	0,4270	0,0009907	154,6	0,4267	0,0009903	155,5	0,4264
40	0,0009951	193,9	0,5607	0,0009947	194,8	0,5603	0,0009943	195,7	0,5599	0,0009939	196,5	0,5596
50	0,0009993	235,0	0,6900	0,0009989	235,9	0,6896	0,0009985	236,8	0,6891	0,0009981	237,6	0,6887
60	0,0010042	276,2	0,8156	0,0010038	277,1	0,8151	0,0010034	277,9	0,8145	0,0010029	278,7	0,8140
70	0,0010096	317,5	0,9376	0,0010092	318,3	0,9370	0,0010087	319,1	0,9364	0,0010083	319,9	0,9359
80	0,0010155	358,8	1,0562	0,0010151	359,6	1,0556	0,0010147	360,4	1,0550	0,0010142	361,2	1,0544
90	0,0010220	400,2	1,1718	0,0010216	401,0	1,1711	0,0010211	401,7	1,1705	0,0010207	402,5	1,1698
100	0,0010290	441,7	1,2845	0,0010285	442,4	1,2838	0,0010281	443,2	1,2830	0,0010276	443,9	1,2823
110	0,0010365	483,3	1,3945	0,0010360	484,0	1,3937	0,0010356	484,7	1,3929	0,0010351	485,5	1,3922
120	0,0010446	525,0	1,5019	0,0010441	525,7	1,5011	0,0010436	526,4	1,5003	0,0010431	527,1	1,4995
130	0,0010531	566,8	1,6070	0,0010526	567,5	1,6061	0,0010521	568,2	1,6053	0,0010516	568,9	1,6044
140	0,0010623	608,8	1,7099	0,0010617	609,5	1,7090	0,0010612	610,2	1,7080	0,0010606	610,8	1,7071

t	p = 30,0 M			p = 31,0 MIIa			p = 32,0 MIIa			p = 33,0 MIIa		
	v	i	s	v	i	s	v	i	s	v	i	s
150	0,0010720	651,0	1,8107	0,0010714	651,6	1,8098	0,0010708	652,3	1,8088	0,0010702	652,9	1,8078
160	0,0010823	693,3	1,9097	0,0010817	693,9	1,9086	0,0010810	694,6	1,9076	0,0010804	695,2	1,9065
170	0,0010932	735,9	2,0068	0,0010926	736,5	2,0057	0,0010919	737,1	2,0046	0,0010913	737,7	2,0035
180	0,0011049	778,7	2,1023	0,0011042	779,2	2,1011	0,0011035	779,8	2,0999	0,0011028	780,4	2,0988
190	0,0011173	821,8	2,1964	0,0011165	822,3	2,1951	0,0011157	822,8	2,1938	0,0011150	823,3	2,1926
200	0,0011304	865,1	2,2890	0,0011296	865,6	2,2877	0,0011288	866,1	2,2863	0,0011280	866,6	2,2850
210	0,0011445	908,9	2,3805	0,0011436	909,3	2,3790	0,0011427	909,8	2,3776	0,0011418	910,2	2,3762
220	0,0011595	953,0	2,4709	0,0011585	953,4	2,4693	0,0011575	953,8	2,4678	0,0011565	954,2	2,4662
230	0,0011755	997,5	2,5603	0,0011744	997,9	2,5587	0,0011734	998,2	2,5570	0,0011723	998,6	2,5554
240	0,0011927	1042,6	2,6490	0,0011916	1042,9	2,6472	0,0011904	1043,2	2,6455	0,0011892	1043,5	2,6437
250	0,0012113	1088,3	2,7371	0,0012100	1088,5	2,7352	0,0012087	1088,7	2,7333	0,0012074	1088,9	2,7314
260	0,0012314	1134,6	2,8248	0,0012299	1134,7	2,8227	0,0012284	1134,8	2,8206	0,0012270	1135,0	2,8186
270	0,0012532	1181,6	2,9122	0,0012515	1181,6	2,9100	0,0012499	1181,7	2,9077	0,0012482	1181,7	2,9055
280	0,0012770	1229,6	2,9997	0,0012751	1229,5	2,9972	0,0012732	1229,4	2,9947	0,0012713	1229,3	2,9923
290	0,0013032	1278,5	3,0874	0,0013010	1278,3	3,0846	0,0012988	1278,1	3,0819	0,0012967	1277,8	3,0793
300	0,0013322	1328,7	3,1756	0,0013296	1328,2	3,1726	0,0013271	1327,9	3,1696	0,0013246	1327,5	3,1666
310	0,0013646	1380,2	3,2648	0,0013616	1379,6	3,2614	0,0013586	1379,0	3,2581	0,0013556	1378,4	3,2547
320	0,0014014	1433,5	3,3554	0,0013977	1432,6	3,3515	0,0013941	1431,7	3,3477	0,0013905	1430,9	3,3440
330	0,0014436	1488,9	3,4481	0,0014390	1487,7	3,4436	0,0014346	1486,4	3,4392	0,0014303	1485,3	3,4349
340	0,0014932	1547,1	3,5437	0,0014873	1545,3	3,5383	0,0014817	1543,6	3,5332	0,0014763	1542,0	3,5281
350	0,0015529	1608,8	3,6435	0,0015452	1606,3	3,6370	0,0015378	1603,9	3,6308	0,0015307	1601,7	3,6247
355	0,0015888	1641,4	3,6956	0,0015799	1638,4	3,6883	0,0015709	1635,6	3,6814	0,0015629	1632,9	3,6746
360	0,0016288	1675,6	3,7498	0,0016171	1672,0	3,7415	0,0016079	1668,6	3,7336	0,0015979	1665,4	3,7261
365	0,0016733	1711,7	3,8066	0,0016600	1707,2	3,7970	0,0016488	1703,1	3,7880	0,0016366	1699,3	3,7794
370	0,0017277	1750,2	3,8667	0,0017100	1744,6	3,8554	0,0016959	1739,6	3,8449	0,0016831	1734,9	3,8350
375	0,0017922	1792,0	3,9314	0,0017700	1784,9	3,9177	0,0017500	1778,5	3,9051	0,0017333	1772,7	3,8935
380	0,0018733	1838,3	4,0026	0,0018433	1828,8	3,9853	0,0018170	1820,5	3,9698	0,0017944	1813,2	3,9557
385	0,0019800	1891,3	4,0834	0,0019366	1878,1	4,0604	0,0018999	1866,9	4,0405	0,0018688	1857,3	4,0230
390	0,0021333	1955,2	4,1802	0,0020611	1935,3	4,1469	0,0020066	1919,4	4,1199	0,0019622	1906,2	4,0971
395	0,0023777	2038,5	4,3053	0,0022444	2005,3	4,2521	0,0021533	1981,1	4,2126	0,0020884	1962,2	4,1812
400	0,0027966	2152,4	4,4750	0,0025333	2095,8	4,3870	0,0023667	2056,8	4,3255	0,0022554	2028,3	4,2197
405	0,0033992	2283,7	4,6694	0,0029766	2209,2	4,5548	0,0026889	2151,2	4,4652	0,0024977	2108,4	4,3982
410	0,0039884	2395,8	4,8342	0,0035133	2324,7	4,7246	0,0031227	2258,5	4,6228	0,0028337	2202,6	4,5367
415	0,0044900	2482,9	4,9612	0,0040233	2422,0	4,8666	0,0036055	2360,2	4,7712	0,0032511	2301,4	4,6808
420	0,0049211	2552,9	5,0625	0,0044470	2500,7	4,9805	0,0040533	2446,5	4,8961	0,0036777	2391,9	4,8118
425	0,0053000	2611,9	5,1473	0,0048633	2566,1	5,0745	0,0044554	2518,5	4,9997	0,0040706	2469,7	4,9237
430	0,0056388	2662,8	5,2201	0,0052133	2622,3	5,1548	0,0048122	2579,9	5,0873	0,0044439	2536,3	5,0187
435	0,0059545	2708,0	5,2841	0,0055530	2671,6	5,2245	0,0051388	2633,6	5,1634	0,0047699	2594,2	5,1008
440	0,0062228	2748,9	5,3416	0,0058919	2715,6	5,2865	0,0054334	2681,2	5,2303	0,0050711	2645,6	5,1730
445	0,0064911	2786,3	5,3939	0,0060877	2755,7	5,3425	0,0057079	2724,1	5,2903	0,0053449	2691,5	5,2372
450	0,0067388	2820,9	5,4419	0,0063388	2792,5	5,3937	0,0059616	2763,3	5,3448	0,0056079	2733,3	5,2952
460	0,0071933	2883,8	5,5284	0,0067998	2859,0	5,4849	0,0064266	2833,5	5,4411	0,0060706	2807,4	5,3970
470	0,0076088	2940,3	5,6049	0,0072151	2918,1	5,5650	0,0068845	2895,4	5,5251	0,0066497	2872,3	5,4850
480	0,0079992	2992,0	5,6740	0,0075999	2971,9	5,6369	0,0072729	2951,4	5,5999	0,0068822	2930,6	5,5629
490	0,0083352	3039,9	5,7372	0,0079557	3021,5	5,7024	0,0075866	3002,9	5,6678	0,0072238	2984,0	5,6333

t	p = 30,0 M			p = 31,0 MIIa			p = 32,0 MIIa			p = 33,0 MIIa		
	v	i	s	v	i	s	v	i	s	v	i	s
500	0,008690	3084,8	5,7956	0,008294	3067,9	5,7627	0,007922	3050,7	5,7301	0,007572	3033,4	5,6976
510	0,009012	3127,2	5,8502	0,008613	3111,6	5,8189	0,008239	3095,7	5,7879	0,007887	3079,6	5,7571
520	0,009320	3167,7	5,9015	0,008917	3153,0	5,8715	0,008540	3138,3	5,8419	0,008186	3123,3	5,8125
530	0,009615	3206,4	5,9500	0,009209	3192,7	5,9212	0,008829	3178,9	5,8928	0,008472	3164,9	5,8646
540	0,009899	3243,7	5,9962	0,009490	3230,8	5,9684	0,009107	3217,8	5,9410	0,008747	3204,7	5,9139
550	0,010175	3279,8	6,0403	0,009762	3267,6	6,0134	0,009375	3255,3	5,9868	0,009011	3243,0	5,9607
560	0,01044	3314,8	6,0826	0,010025	3303,3	6,0564	0,009634	3291,7	6,0307	0,009267	3280,0	6,0054
570	0,01070	3348,9	6,1233	0,01028	3338,0	6,0978	0,009886	3327,0	6,0728	0,009515	3315,9	6,0482
580	0,01096	3382,3	6,1626	0,01053	3371,8	6,1377	0,010131	3361,4	6,1134	0,009756	3350,8	6,0894
590	0,01120	3414,9	6,2006	0,01077	3404,9	6,1763	0,01037	3394,9	6,1525	0,009991	3384,9	6,1291
600	0,01144	3446,9	6,2374	0,01101	3437,4	6,2137	0,01060	3427,8	6,1904	0,010221	3418,3	6,1675
610	0,01168	3478,3	6,2732	0,01124	3469,2	6,2500	0,01083	3460,1	6,2271	0,01044	3451,0	6,2047
620	0,01191	3509,3	6,3081	0,01147	3500,6	6,2853	0,01106	3491,8	6,2629	0,01066	3483,1	6,2409
630	0,01214	3539,8	6,3421	0,01170	3531,4	6,3196	0,011285	3523,0	6,2976	0,01088	3514,6	6,2761
640	0,01237	3569,9	6,3752	0,01192	3561,9	6,3532	0,01149	3553,8	6,3315	0,01109	3545,8	6,3103
650	0,01259	3599,7	6,4077	0,01213	3592,0	6,3859	0,01170	3584,2	6,3646	0,01130	3576,4	6,3437
660	0,01281	3629,1	6,4394	0,01235	3621,7	6,4179	0,01191	3614,2	6,3969	0,01151	3606,8	6,3764
670	0,01302	3658,3	6,4705	0,01256	3651,1	6,4493	0,01212	3643,9	6,4286	0,01171	3636,7	6,4083
680	0,01324	3687,2	6,5009	0,01276	3680,2	6,4800	0,01232	3673,3	6,4596	0,01191	3666,4	6,4396
690	0,01345	3715,8	6,5308	0,01297	3709,1	6,5102	0,01252	3702,4	6,4900	0,01210	3695,7	6,4703
700	0,01365	3744,2	6,5602	0,01317	3737,8	6,5398	0,01272	3731,3	6,5198	0,01230	3724,8	6,5003
710	0,01386	3772,5	6,5891	0,01337	3766,2	6,5689	0,01292	3760,0	6,5491	0,01249	3753,7	6,5298
720	0,01406	3800,5	6,6175	0,01357	3794,5	6,5975	0,01311	3788,4	6,5779	0,01268	3782,4	6,5589
730	0,01426	3828,4	6,6454	0,01377	3822,6	6,6256	0,01330	3816,7	6,6063	0,01287	3810,9	6,5874
740	0,01446	3856,2	6,6729	0,01396	3850,5	6,6533	0,01349	3844,8	6,6341	0,01305	3839,1	6,6154
750	0,01466	3883,8	6,7000	0,01416	3878,3	6,6806	0,01368	3872,8	6,6616	0,01324	3867,3	6,6431
760	0,01486	3911,3	6,7268	0,01435	3905,9	6,7075	0,01387	3900,6	6,6887	0,01342	3895,3	6,6703
770	0,01505	3938,7	6,7532	0,01454	3933,5	6,7340	0,01405	3928,3	6,7153	0,01360	3923,1	6,6971
780	0,01525	3965,9	6,7792	0,01473	3960,9	6,7602	0,01424	3955,9	6,7416	0,01378	3950,8	6,7236
790	0,01544	3993,1	6,8049	0,01491	3988,2	6,7860	0,01442	3983,3	6,7676	0,01396	3978,5	6,7497
800	0,01563	4020,2	6,8303	0,01510	4015,5	6,8115	0,01460	4010,7	6,7932	0,01413	4006,0	6,7754

3-jadval (davomi)

t	p = 34,0 MIIa			p = 35,0 M			p = 36,0 MIIa			p = 37,0 MIIa		
	v	i	s	v	i	s	v	i	s	v	i	s
0	0,0009838	33,8	0,0001	0,0009834	34,7	0,0001	0,0009829	35,7	0,0000	0,0009825	36,7	0,0000
10	0,0009849	74,6	0,1468	0,0009845	75,5	0,1466	0,0009840	76,4	0,1465	0,0009836	77,4	0,1463
20	0,0009870	115,4	0,2887	0,0009866	116,3	0,2884	0,0009861	117,3	0,2882	0,0009857	118,2	0,2879
30	0,0009899	156,4	0,4261	0,0009895	157,3	0,4257	0,0009891	158,2	0,4254	0,0009887	159,1	0,4251
40	0,0009935	197,4	0,5592	0,0009931	198,3	0,5588	0,0009927	199,1	0,5584	0,0009923	200,0	0,5580
50	0,0009977	238,5	0,6882	0,0009973	239,3	0,6878	0,0009969	240,2	0,6873	0,0009965	241,0	0,6869
60	0,0010025	279,6	0,8135	0,0010021	280,4	0,8130	0,0010017	281,2	0,8125	0,0010013	282,1	0,8120
70	0,0010079	320,7	0,9353	0,0010075	321,6	0,9347	0,0010071	322,4	0,9342	0,0010067	323,2	0,9336
80	0,0010138	362,0	1,0537	0,0010134	362,8	1,0531	0,0010130	363,6	1,0525	0,0010126	364,4	1,0519

t	p = 34,0 МПа			p = 35,0 М			p = 36,0 МПа			p = 37,0 МПа		
	v	i	s	v	i	s	v	i	s	v	i	s
90	0,0010202	403,3	1,1691	0,0010198	404,1	1,1685	0,0010194	404,9	1,1678	0,0010189	405,6	1,1671
100	0,0010272	444,7	1,2816	0,0010267	445,5	1,2809	0,0010263	446,2	1,2802	0,0010258	447,0	1,2795
110	0,0010346	486,2	1,3914	0,0010341	487,0	1,3906	0,0010337	487,7	1,3898	0,0010332	488,4	1,3891
120	0,0010426	527,8	1,4986	0,0010421	528,6	1,4978	0,0010416	529,3	1,4970	0,0010411	530,0	1,4962
130	0,0010511	569,6	1,6035	0,0010505	570,3	1,6026	0,0010500	571,0	1,6018	0,0010495	571,7	1,6009
140	0,0010601	611,5	1,7062	0,0010595	612,2	1,7052	0,0010590	612,9	1,7043	0,0010585	613,5	1,7034
150	0,0010697	653,6	1,8068	0,0010691	654,2	1,8058	0,0010685	654,9	1,8048	0,0010679	655,5	1,8038
160	0,0010798	695,8	1,9054	0,0010792	696,4	1,9044	0,0010786	697,1	1,9034	0,0010780	697,7	1,9023
170	0,0010906	738,3	2,0023	0,0010900	738,9	2,0012	0,0010893	739,5	2,0001	0,0010887	740,1	1,9990
180	0,0011021	780,9	2,0976	0,0011014	781,5	2,0964	0,0011007	782,1	2,0952	0,0011000	782,6	2,0941
190	0,0011142	823,9	2,1913	0,0011135	824,4	2,1900	0,0011127	824,9	2,1888	0,0011120	825,5	2,1876
200	0,0011272	867,1	2,2836	0,0011264	867,6	2,2823	0,0011256	868,1	2,2810	0,0011248	868,6	2,2797
210	0,0011409	910,7	2,3747	0,0011400	911,1	2,3733	0,0011392	911,6	2,3719	0,0011383	912,0	2,3705
220	0,0011556	954,6	2,4647	0,0011546	955,0	2,4632	0,0011537	955,4	2,4617	0,0011528	955,8	2,4602
230	0,0011713	998,9	2,5538	0,0011702	999,3	2,5521	0,0011692	999,7	2,5505	0,0011682	1000,0	2,5489
240	0,0011881	1043,8	2,6420	0,0011869	1044,1	2,6402	0,0011858	1044,4	2,6385	0,0011846	1044,7	2,6368
250	0,0012061	1089,1	2,7295	0,0012048	1089,4	2,7276	0,0012036	1089,6	2,7258	0,0012023	1089,8	2,7240
260	0,0012255	1135,1	2,8166	0,0012241	1135,2	2,8145	0,0012227	1135,4	2,8125	0,0012213	1135,6	2,8106
270	0,0012466	1181,8	2,9033	0,0012450	1181,8	2,9011	0,0012434	1181,9	2,8989	0,0012419	1182,0	2,8968
280	0,0012695	1229,3	2,9899	0,0012677	1229,2	2,9875	0,0012659	1229,2	2,9852	0,0012641	1229,1	2,9828
290	0,0012946	1277,7	3,0766	0,0012925	1277,5	3,0740	0,0012904	1277,3	3,0714	0,0012884	1277,2	3,0689
300	0,0013221	1327,1	3,1637	0,0013197	1326,8	3,1608	0,0013174	1326,5	3,1580	0,0013151	1326,2	3,1552
310	0,0013528	1377,9	3,2515	0,0013500	1377,4	3,2483	0,0013472	1376,9	3,2451	0,0013445	1376,4	3,2420
320	0,0013871	1430,1	3,3403	0,0013837	1429,4	3,3367	0,0013805	1428,6	3,3331	0,0013773	1427,9	3,3296
330	0,0014261	1484,2	3,4307	0,0014220	1483,1	3,4265	0,0014180	1482,1	3,4225	0,0014142	1481,1	3,4185
340	0,0014710	1540,4	3,5232	0,0014660	1539,0	3,5184	0,0014611	1537,6	3,5137	0,0014563	1536,2	3,5091
350	0,0015239	1599,6	3,6188	0,0015175	1597,5	3,6131	0,0015112	1595,6	3,6076	0,0015052	1593,8	3,6022
355	0,001554	1630,4	3,6682	0,001547	1628,1	3,6619	0,0015450	1625,8	3,6559	0,001533	1623,7	3,6500
360	0,001588	1662,4	3,7189	0,001579	1659,6	3,7119	0,001571	1657,0	3,7053	0,001563	1654,4	3,6988
365	0,001625	1695,7	3,7713	0,001615	1692,4	3,7635	0,001605	1689,2	3,7560	0,001596	1686,3	3,7489
370	0,001668	1730,6	3,8257	0,001656	1726,6	3,8169	0,001644	1722,8	3,8085	0,001633	1719,3	3,8004
375	0,001716	1767,4	3,8827	0,001702	1762,5	3,8725	0,001688	1758,0	3,8629	0,001675	1753,8	3,8538
380	0,001773	1806,5	3,9429	0,001755	1800,5	3,9309	0,001738	1795,0	3,9198	0,001722	1789,9	3,9094
385	0,001841	1848,8	4,0073	0,001818	1841,2	3,9930	0,001796	1834,3	3,9798	0,001777	1828,1	3,9677
390	0,001925	1895,0	4,0773	0,001893	1885,3	4,0597	0,001865	1876,6	4,0438	0,001841	1868,9	4,0293
395	0,002031	1946,8	4,1551	0,001986	1933,8	4,1326	0,001949	1922,6	4,1129	0,001917	1912,8	4,0953
400	0,002170	2006,3	4,2437	0,002106	1988,4	4,2140	0,002053	1973,5	4,1888	0,002009	1960,8	4,1669
405	0,002362	2076,1	4,3471	0,002263	2051,1	4,3067	0,002186	2030,8	4,2736	0,002125	2014,0	4,2456
410	0,002627	2158,3	4,4678	0,002474	2123,6	4,4133	0,002360	2096,0	4,3693	0,002272	2073,5	4,3331
415	0,002968	2249,3	4,6005	0,002751	2205,5	4,5327	0,002586	2169,6	4,4767	0,002460	2140,3	4,4305
420	0,003352	2339,4	4,7309	0,003082	2291,3	4,6570	0,002865	2249,3	4,5921	0,002694	2213,5	4,5364
425	0,003735	2420,8	4,8481	0,003435	2373,5	4,7752	0,003180	2329,4	4,7073	0,002967	2289,7	4,6460
430	0,004094	2491,9	4,9495	0,003782	2447,7	4,8811	0,003505	2404,8	4,8149	0,003264	2364,3	4,7524
435	0,004425	2554,0	5,0375	0,004109	2513,4	4,9742	0,003821	2473,1	4,9117	0,003563	2433,9	4,8511
440	0,004731	2609,0	5,1149	0,004413	2571,6	5,0561	0,004121	2534,3	4,9977	0,003854	2497,2	4,9402

t	p = 34,0 МПа			p = 35,0 М			p = 36,0 МПа			p = 37,0 МПа		
	v	i	s	v	i	s	v	i	s	v	i	s
445	0,005012	2658,0	5,1834	0,004696	2623,9	5,1291	0,004402	2589,2	5,0746	0,004130	2554,6	5,0204
450	0,005273	2702,4	5,2451	0,004959	2671,0	5,1945	0,004665	2639,0	5,1436	0,004391	2606,8	5,0928
460	0,005746	2780,7	5,3526	0,005436	2753,5	5,3079	0,005143	2725,9	5,2630	0,004869	2697,9	5,2179
470	0,006169	2848,8	5,4448	0,005861	2824,8	5,4045	0,005570	2800,5	5,3641	0,005296	2775,9	5,3236
480	0,006555	2909,5	5,5260	0,006246	2888,1	5,4890	0,005956	2866,3	5,4521	0,005682	2844,3	5,4151
490	0,006911	2964,8	5,5989	0,006602	2945,3	5,5646	0,006311	2925,7	5,5303	0,006036	2905,8	5,4962
500	0,007243	3015,8	5,6653	0,006933	2998,0	5,6331	0,006641	2980,1	5,6011	0,006365	2961,9	5,5693
510	0,007556	3063,4	5,7265	0,007245	3047,0	5,6961	0,006951	3030,5	5,6660	0,006673	3013,8	5,6360
520	0,007853	3108,3	5,7834	0,007540	3093,1	5,7546	0,007244	3077,8	5,7259	0,006964	3062,3	5,6975
530	0,008137	3150,9	5,8368	0,007821	3136,7	5,8092	0,007522	3122,4	5,7819	0,007241	3108,0	5,7548
540	0,008408	3191,5	5,8871	0,008089	3178,2	5,8606	0,007788	3164,9	5,8344	0,007504	3151,4	5,8085
550	0,008670	3230,6	5,9348	0,008348	3218,1	5,9093	0,008044	3205,5	5,8841	0,007757	3192,9	5,8592
560	0,008922	3268,3	5,9804	0,008597	3256,5	5,9557	0,008290	3244,6	5,9313	0,008001	3232,7	5,9072
570	0,009167	3304,8	6,0239	0,008838	3293,6	6,0000	0,008529	3282,4	5,9764	0,008236	3271,1	5,9531
580	0,009404	3340,3	6,0658	0,009073	3329,6	6,0425	0,008760	3319,0	6,0195	0,008464	3308,3	5,9969
590	0,009636	3374,8	6,1061	0,009301	3364,7	6,0834	0,008985	3354,6	6,0610	0,008686	3344,4	6,0390
600	0,009862	3408,7	6,1450	0,009523	3399,0	6,1229	0,009204	3389,3	6,1011	0,008902	3379,7	6,0796
610	0,010082	3441,8	6,1827	0,009740	3432,6	6,1611	0,009417	3423,3	6,1398	0,009112	3414,1	6,1188
620	0,01030	3474,3	6,2193	0,009953	3465,5	6,1981	0,009627	3456,6	6,1772	0,009318	3447,8	6,1567
630	0,01051	3506,2	6,2549	0,01016	3497,8	6,2341	0,009831	3489,3	6,2136	0,009520	3480,8	6,1935
640	0,01072	3537,7	6,2895	0,01036	3529,6	6,2691	0,010032	3521,4	6,2490	0,009717	3513,3	6,2293
650	0,01092	3568,7	6,3233	0,01057	3560,9	6,3032	0,01023	3553,1	6,2835	0,009911	3545,3	6,2641
660	0,01112	3599,3	6,3563	0,01076	3591,8	6,3365	0,01042	3584,3	6,3171	0,010101	3576,7	6,2980
670	0,01132	3629,5	6,3885	0,01096	3622,3	6,3690	0,01061	3615,1	6,3499	0,01029	3607,8	6,3312
680	0,01152	3659,4	6,4200	0,01115	3652,5	6,4008	0,01080	3645,5	6,3820	0,01047	3638,5	6,3635
690	0,01171	3689,0	6,4509	0,01134	3682,3	6,4320	0,01099	3675,6	6,4134	0,01066	3668,9	6,3952
700	0,01190	3718,4	6,4812	0,01152	3711,9	6,4625	0,01117	3705,4	6,4442	0,01083	3698,9	6,4262
710	0,01209	3747,5	6,5110	0,01171	3741,2	6,4925	0,01135	3734,9	6,4744	0,01101	3728,7	6,4567
720	0,01227	3776,3	6,5402	0,01189	3770,3	6,5219	0,01153	3764,2	6,5040	0,01119	3758,1	6,4865
730	0,01246	3805,0	6,5689	0,01207	3799,1	6,5508	0,01170	3793,3	6,5331	0,01136	3787,4	6,5158
740	0,01264	3833,5	6,5972	0,01225	3827,8	6,5793	0,01188	3822,1	6,5618	0,01153	3816,4	6,5446
750	0,01282	3861,8	6,6250	0,01242	3856,3	6,6072	0,01205	3850,8	6,5899	0,01170	3845,3	6,5729
760	0,01300	3889,9	6,6523	0,01260	3884,6	6,6348	0,01222	3879,2	6,6176	0,01187	3873,9	6,6008
770	0,01318	3917,9	6,6793	0,01277	3912,7	6,6619	0,01239	3907,6	6,6449	0,01203	3902,4	6,6282
780	0,01335	3945,8	6,7059	0,01294	3940,8	6,6887	0,01256	3935,7	6,6718	0,01220	3930,7	6,6553
790	0,01352	3973,6	6,7322	0,01311	3968,7	6,7150	0,01272	3963,8	6,6983	0,01236	3958,9	6,6819
800	0,01369	4001,2	6,7580	0,01328	3996,5	6,7411	0,01289	3991,7	6,7244	0,01252	3987,0	6,7082

3-jadval (davomi)

t	p = 38,0 МПа			p = 39,0 МПа			p = 40,0 МПа			p = 41,0 МПа		
	v	i	s	v	i	s	v	i	s	v	i	s
0	0,0009820	37,6	-0,0001	0,0009816	38,6	-0,0002	0,0009811	39,6	-0,0002	0,0009807	40,5	-0,0003
10	0,0009832	78,3	0,1461	0,0009828	79,2	0,1460	0,0009823	80,2	0,1458	0,0009819	81,1	0,1456
20	0,0009853	119,1	0,2877	0,0009849	120,0	0,2874	0,0009845	120,9	0,2872	0,0009841	121,8	0,2869

t	p = 38,0 МПа			p = 39,0 МПа			p = 40,0 МПа			p = 41,0 МПа		
	v	i	s	v	i	s	v	i	s	v	i	s
30	0,0009883	159,9	0,4248	0,0009878	160,8	0,4244	0,0009874	161,7	0,4241	0,0009870	162,6	0,4238
40	0,0009919	200,9	0,5576	0,0009915	201,7	0,5572	0,0009911	202,6	0,5568	0,0009907	203,5	0,5564
50	0,0009961	241,9	0,6864	0,0009957	242,7	0,6860	0,0009953	243,6	0,6855	0,0009949	244,4	0,6851
60	0,0010009	282,9	0,8115	0,0010005	283,7	0,8110	0,0010001	284,6	0,8105	0,0009997	285,4	0,8100
70	0,0010063	324,0	0,9330	0,0010059	324,8	0,9325	0,0010054	325,6	0,9319	0,0010050	326,4	0,9314
80	0,0010121	365,2	1,0513	0,0010117	366,0	1,0507	0,0010113	366,8	1,0501	0,0010109	367,6	1,0495
90	0,0010185	406,4	1,1665	0,0010181	407,2	1,1658	0,0010176	408,0	1,1651	0,0010172	408,7	1,1645
100	0,0010254	447,7	1,2787	0,0010249	448,5	1,2780	0,0010245	449,3	1,2773	0,0010240	450,0	1,2766
110	0,0010327	489,2	1,3883	0,0010323	489,9	1,3876	0,0010318	490,7	1,3868	0,0010314	491,4	1,3860
120	0,0010406	530,7	1,4954	0,0010401	531,4	1,4946	0,0010397	532,2	1,4937	0,0010392	532,9	1,4929
130	0,0010490	572,4	1,6000	0,0010485	573,1	1,5992	0,0010480	573,8	1,5983	0,0010475	574,5	1,5975
140	0,0010579	614,2	1,7025	0,0010574	614,9	1,7016	0,0010569	615,6	1,7006	0,0010563	616,2	1,6997
150	0,0010674	656,2	1,8029	0,0010668	656,8	1,8019	0,0010663	657,5	1,8009	0,0010657	658,1	1,7999
160	0,0010774	698,3	1,9013	0,0010768	699,0	1,9003	0,0010762	699,6	1,8992	0,0010756	700,2	1,8982
170	0,0010880	740,7	1,9979	0,0010874	741,3	1,9968	0,0010868	741,9	1,9957	0,0010861	742,5	1,9947
180	0,0010993	783,2	2,0929	0,0010986	783,8	2,0917	0,0010980	784,4	2,0906	0,0010973	784,9	2,0894
190	0,0011113	826,0	2,1863	0,0011105	826,6	2,1851	0,0011098	827,1	2,1839	0,0011091	827,7	2,1827
200	0,0011240	869,1	2,2784	0,0011232	869,6	2,2771	0,0011224	870,1	2,2758	0,0011216	870,6	2,2745
210	0,0011375	912,5	2,3691	0,0011366	913,0	2,3677	0,0011358	913,4	2,3663	0,0011349	913,9	2,3650
220	0,0011518	956,3	2,4587	0,0011509	956,7	2,4573	0,0011500	957,1	2,4558	0,0011491	957,5	2,4543
230	0,0011671	1000,4	2,5473	0,0011661	1000,8	2,5458	0,0011651	1001,1	2,5442	0,0011641	1001,5	2,5426
240	0,0011835	1045,0	2,6351	0,0011824	1045,3	2,6334	0,0011813	1045,6	2,6317	0,0011802	1045,9	2,6301
250	0,0012011	1090,1	2,7221	0,0011999	1090,3	2,7203	0,0011986	1090,6	2,7185	0,0011974	1090,8	2,7167
260	0,0012200	1135,7	2,8086	0,0012186	1135,9	2,8066	0,0012172	1136,1	2,8047	0,0012159	1136,3	2,8028
270*	0,0012403	1182,1	2,8947	0,0012388	1182,2	2,8926	0,0012373	1182,3	2,8905	0,0012358	1182,4	2,8884
280	a,0012624	1229,1	2,9805	0,0012607	1229,1	2,9782	0,0012590	1229,1	2,9760	0,0012573	1229,1	2,9737
290	0,0012864	1277,0	3,0664	0,0012845	1276,9	3,0639	0,0012825	1276,8	3,0614	0,0012806	1276,7	3,0589
300	0,0013128	1325,9	3,1524	0,0013105	1325,7	3,1497	0,0013083	1325,4	3,1469	0,0013061	1325,2	3,1443
310	0,0013418	1375,9	3,2389	0,0013392	1375,5	3,2359	0,0013366	1375,1	3,2329	0,0013341	1374,7	3,2299
320	0,0013741	1427,3	3,3262	0,0013710	1426,6	3,3228	0,0013680	1426,0	3,3195	0,0013651	1425,4	3,3162
330	0,0014104	1480,2	3,4146	0,0014067	1479,3	3,4108	0,0014031	1478,4	3,4070	0,0013996	1477,6	3,4033
340	0,0014517	1534,9	3,5047	0,0014472	1533,7	3,5003	0,0014428	1532,5	3,4960	0,0014386	1531,4	3,4918
350	0,0014994	1592,0	3,5970	0,0014938	1590,3	3,5919	0,0014884	1588,7	3,5870	0,0014832	1587,2	3,5821
355	0,001526	1621,6	3,6443	0,001520	1619,7	3,6388	0,001514	1617,8	3,6334	0,001508	1616,0	3,6282
360	0,001556	1652,1	3,6926	0,001548	1649,8	3,6865	0,001542	1647,6	3,6807	0,001535	1645,6	3,6750
365	0,001588	1683,5	3,7420	0,001580	1680,8	3,7353	0,001572	1678,3	3,7289	0,001564	1675,9	3,7227
370	0,001623	1716,0	3,7928	0,001614	1712,9	3,7854	0,001605	1709,9	3,7783	0,001596	1707,1	3,7715
375	0,001663	1749,8	3,8452	0,001652	1746,1	3,8369	0,001641	1742,7	3,8290	0,001631	1739,4	3,8215
380	0,001708	1785,2	3,8995	0,001695	1780,8	3,8902	0,001682	1776,7	3,8814	0,001670	1772,9	3,8729
385	0,001759	1822,4	3,9563	0,001743	1817,2	3,9456	0,001728	1812,3	3,9356	0,001714	1807,7	3,9261
390	0,001819	1861,9	4,0160	0,001799	1855,5	4,0036	0,001780	1849,6	3,9921	0,001764	1844,2	3,9813
395	0,001888	1904,1	4,0794	0,001863	1896,2	4,0648	0,001841	1889,1	4,0514	0,001820	1882,6	4,0389
400	0,001972	1949,7	4,1475	0,001939	1939,9	4,1300	0,001911	1931,1	4,1141	0,001885	1927,4	4,0995
405	0,002074	1999,7	4,2214	0,002031	1987,2	4,2000	0,001994	1976,3	4,1809	0,001961	1966,5	4,1636
410	0,002201	2054,8	4,3025	0,002143	2038,9	4,2760	0,002093	2025,2	4,2527	0,002051	2013,1	4,2320

t	p = 38,0 МПа			p = 39,0 МПа			p = 40,0 МПа			p = 41,0 МПа		
	v	i	s	v	i	s	v	i	s	v	i	s
415	0,002360	2116,1	4,3918	0,002280	2095,8	4,3589	0,002214	2078,4	4,3304	0,002159	2063,4	4,3053
420	0,002558	2183,4	4,4892	0,002449	2157,9	4,4489	0,002361	2136,3	4,4142	0,002288	2117,7	4,3840
425	0,002794	2254,8	4,5919	0,002653	2224,6	4,5447	0,002537	2198,6	4,5037	0,002442	2176,1	4,4679
430	0,003058	2327,0	4,6950	0,002886	2293,5	4,6431	0,002742	2263,8	4,5969	0,002623	2237,7	4,5559
435	0,003336	2396,5	4,7934	0,003139	2361,7	4,7397	0,002970	2329,8	4,6903	0,002826	2301,0	4,6455
440	0,003613	2461,2	4,8844	0,003398	2426,6	4,8310	0,003210	2394,0	4,7807	0,003045	2363,8	4,7339
445	0,003881	2520,4	4,9672	0,003656	2487,0	4,9155	0,003453	2454,9	4,8658	0,003272	2424,4	4,8187
450	0,004138	2574,6	5,0423	0,003905	2542,8	4,9928	0,003693	2511,8	4,9447	0,003501	2481,8	4,8983
460	0,004612	2669,6	5,1730	0,004372	2641,4	5,1283	0,004149	2613,3	5,0842	0,003943	2585,6	5,0409
470	0,005038	2750,9	5,2831	0,004795	2725,8	5,2427	0,004567	2700,7	5,2026	0,004354	2675,6	5,1628
480	0,005423	2822,1	5,3783	0,005180	2799,7	5,3415	0,004950	2777,2	5,3048	0,004733	2754,6	5,2684
490	0,005777	2885,8	5,4622	0,005532	2865,5	5,4283	0,005300	2845,2	5,3946	0,005082	2824,8	5,3610
500	0,006105	2943,6	5,5376	0,005858	2925,2	5,5060	0,005625	2906,7	5,4746	0,005404	2888,1	5,4434
510	0,006411	2997,0	5,6062	0,006163	2980,1	5,5765	0,005928	2963,1	5,5471	0,005705	2946,0	5,5178
520	0,006700	3046,8	5,6693	0,006450	3031,1	5,6413	0,006213	3015,4	5,6135	0,005988	2999,6	5,5859
530	0,006974	3093,6	5,7279	0,006722	3079,0	5,7013	0,006483	3064,4	5,6749	0,006256	3049,8	5,6487
540	0,007235	3137,9	5,7828	0,006981	3124,3	5,7574	0,006740	3110,7	5,7322	0,006511	3097,0	5,7072
550	0,007486	3180,2	5,8345	0,007229	3167,4	5,8101	0,006985	3154,6	5,7859	0,006754	3141,8	5,7620
560	0,007727	3220,7	5,8834	0,007467	3208,7	5,8599	0,007221	3196,7	5,8366	0,006988	3184,6	5,8136
570	0,007959	3259,8	5,9300	0,007697	3248,4	5,9073	0,007449	3237,0	5,8848	0,007213	3225,6	5,8626
580	0,008185	3297,6	5,9746	0,007920	3286,8	5,9525	0,007669	3276,0	5,9308	0,007430	3265,2	5,9092
590	0,008403	3334,2	6,0173	0,008136	3324,0	5,9959	0,007882	3313,8	5,9747	0,007641	3303,5	5,9539
600	0,008616	3369,9	6,0584	0,008346	3360,2	6,0376	0,008089	3350,4	6,0170	0,007845	3340,7	5,9967
610	0,008824	3404,8	6,0981	0,008550	3395,5	6,0778	0,008291	3386,2	6,0577	0,008045	3376,9	6,0379
620	0,009027	3438,9	6,1365	0,008750	3430,0	6,1166	0,008488	3421,1	6,0970	0,008239	3412,2	6,0777
630	0,009225	3472,3	6,1737	0,008946	3463,8	6,1543	0,008681	3455,3	6,1351	0,008429	3446,8	6,1162
640	0,009419	3505,1	6,2099	0,009137	3497,0	6,1908	0,008869	3488,8	6,1720	0,008614	3480,6	6,1535
650	0,009610	3537,4	6,2451	0,009325	3529,6	6,2263	0,009054	3521,8	6,2079	0,008796	3513,9	6,1897
660	0,009797	3569,2	6,2793	0,009509	3561,7	6,2609	0,009235	3554,2	6,2428	0,008975	3546,6	6,2250
670	0,009981	3600,6	6,3128	0,009690	3593,3	6,2946	0,009413	3586,1	6,2768	0,009150	3578,8	6,2593
680	0,010163	3631,5	6,3454	0,009868	3624,6	6,3276	0,009589	3617,6	6,3100	0,009323	3610,6	6,2928
690	0,01034	3662,1	6,3773	0,010043	3655,4	6,3598	0,009761	3648,7	6,3425	0,009493	3642,0	6,3255
700	0,01052	3692,4	6,4086	0,01022	3685,9	6,3913	0,009931	3679,4	6,3743	0,009660	3672,9	6,3575
710	0,01069	3722,4	6,4392	0,01039	3716,1	6,4221	0,010099	3709,8	6,4053	0,009825	3703,6	6,3888
720	0,01086	3752,1	6,4693	0,01056	3746,0	6,4524	0,01026	3740,0	6,4358	0,009987	3733,9	6,4195
730	0,01103	3781,5	6,4988	0,01072	3775,7	6,4821	0,01043	3769,8	6,4657	0,01015	3763,9	6,4496
740	0,01120	3810,7	6,5278	0,01089	3805,1	6,5113	0,01059	3799,4	6,4951	0,01031	3793,7	6,4792
750	0,01136	3839,7	6,5563	0,01105	3834,2	6,5399	0,01075	3828,8	6,5239	0,01046	3823,3	6,5082
760	0,01153	3868,6	6,5843	0,01121	3863,2	6,5681	0,01090	3857,9	6,5523	0,01062	3852,6	6,5367
770	0,01169	3897,2	6,6119	0,01137	3892,0	6,5959	0,01106	3886,9	6,5802	0,01077	3881,7	6,5648
780	0,01185	3925,7	6,6391	0,01153	3920,7	6,6232	0,01122	3915,7	6,6077	0,01092	3910,7	6,5924
790	0,01201	3954,0	6,6659	0,01168	3949,2	6,6501	0,01137	3944,3	6,6347	0,01107	3939,5	6,6196
800	0,01217	3982,3	6,6923	0,01184	3977,5	6,6767	0,01152	3972,8	6,6614	0,01122	3968,1	6,6464

3-Jadval (davomi)

t	p = 42,0 MПа			p = 43,0 MПа			p = 44,0 MПа			p = 45,0 MПа		
	v	i	s	v	i	s	v	i	s	v	i	s
0	0,0009802	41,5	- 0,0004	0,0009798	42,4	- 0,0004	0,0009794	43,4	- 0,0005	0,0009789	44,4	- 0,0006
10	0,0009815	82,0	0,1455	0,0009811	83,0	0,1453	0,0009807	83,9	0,1451	0,0009802	84,8	0,1449
20	0,0009837	122,7	0,2867	0,0009833	123,6	0,2864	0,0009829	124,5	0,2861	0,0009825	125,4	0,2859
30	0,0009866	163,5	0,4234	0,0009862	164,4	0,4231	0,0009859	165,3	0,4228	0,0009855	166,2	0,4224
40	0,0009903	204,3	0,5560	0,0009899	205,2	0,5556	0,0009895	206,1	0,5552	0,0009891	206,9	0,5548
50	0,0009945	245,3	0,6846	0,0009941	246,1	0,6842	0,0009937	247,0	0,6837	0,0009933	247,8	0,6832
60	0,0009993	286,2	0,8095	0,0009989	287,1	0,8089	0,0009985	287,9	0,8084	0,0009981	288,7	0,8079
70	0,0010046	327,3	0,9308	0,0010042	328,1	0,9302	0,0010038	328,9	0,9297	0,0010034	329,7	0,9291
80	0,0010105	368,3	1,0488	0,0010101	369,1	1,0482	0,0010096	369,9	1,0476	0,0010092	370,7	1,0470
90	0,0010168	409,5	1,1638	0,0010164	410,3	1,1632	0,0010159	411,1	1,1625	0,0010155	411,9	1,1619
100	0,0010236	450,8	1,2759	0,0010232	451,5	1,2752	0,0010227	452,3	1,2745	0,0010223	453,1	1,2738
110	0,0010309	492,1	1,3853	0,0010305	492,9	1,3845	0,0010300	493,6	1,3838	0,0010295	494,4	1,3830
120	0,0010387	533,6	1,4921	0,0010382	534,3	1,4913	0,0010377	535,1	1,4905	0,0010373	535,8	1,4897
130	0,0010470	575,2	1,5966	0,0010465	575,9	1,5957	0,0010460	576,6	1,5949	0,0010455	577,3	1,5940
140	0,0010558	616,9	1,6988	0,0010553	617,6	1,6979	0,0010548	618,3	1,6970	0,0010542	619,0	1,6961
150	0,0010651	658,8	1,7990	0,0010646	659,5	1,7980	0,0010640	660,1	1,7971	0,0010635	660,8	1,7961
160	0,0010750	700,9	1,8972	0,0010745	701,5	1,8962	0,0010739	702,1	1,8952	0,0010733	702,8	1,8941
170	0,0010855	743,1	1,9936	0,0010849	743,7	1,9925	0,0010843	744,3	1,9914	0,0010837	744,9	1,9904
180	0,0010966	785,5	2,0883	0,0010960	786,1	2,0871	0,0010953	786,7	2,0860	0,0010946	787,3	2,0849
190	0,0011084	828,2	2,1814	0,0011077	828,8	2,1802	0,0011070	829,3	2,1790	0,0011063	829,9	2,1778
200	0,0011209	871,1	2,2732	0,0011201	871,7	2,2719	0,0011193	872,2	2,2706	0,0011186	872,7	2,2693
210	0,0011341	914,4	2,3636	0,0011334	914,9	2,3622	0,0011325	915,3	2,3609	0,0011316	915,8	2,3595
220	0,0011482	958,0	2,4529	0,0011473	958,4	2,4514	0,0011464	958,8	2,4500	0,0011455	959,3	2,4485
230	0,0011632	1001,9	2,5411	0,0011622	1002,3	2,5395	0,0011612	1002,7	2,5380	0,0011602	1003,1	2,5365
240	0,0011791	1046,3	2,6284	0,0011781	1046,6	2,6268	0,0011770	1046,9	2,6251	0,0011760	1047,3	2,6235
250	0,0011962	1091,1	2,7150	0,0011951	1091,4	2,7132	0,0011939	1091,7	2,7114	0,0011927	1092,0	2,7097
260	0,0012146	1136,5	2,8009	0,0012133	1136,7	2,7990	0,0012120	1136,9	2,7971	0,0012107	1137,1	2,7952
270	0,0012343	1182,5	2,8863	0,0012329	1182,6	2,8843	0,0012314	1182,7	2,8823	0,0012300	1182,9	2,8803
280	0,0012556	1229,2	2,9715	0,0012540	1229,2	2,9693	0,0012524	1229,2	2,9671	0,0012508	1229,3	2,9649
290	0,0012788	1276,6	3,0565	0,0012769	1276,5	3,0541	0,0012751	1276,5	3,0517	0,0012733	1276,4	3,0494
300	0,0013040	1325,0	3,1416	0,0013019	1324,8	3,1390	0,0012998	1324,6	3,1364	0,0012977	1324,4	3,1338
310	0,0013316	1374,3	3,2270	0,0013292	1374,0	3,2241	0,0013268	1373,7	3,2213	0,0013245	1373,3	3,2185
320	0,0013622	1424,9	3,3129	0,0013594	1424,3	3,3097	0,0013566	1423*8	3,3066	0,0013538	1423,3	3,3035
330	0,0013962	1476,8	3,3997	0,0013929	1476,0	3,3961	0,0013896	1475,3	3,3926	0,0013864	1474,6	3,3892
340	0,0014345	1530,3	3,4877	0,0014305	1529,3	3,4837	0,0014265	1528,3	3,4797	0,0014227	1527,3	3,4758
350	0,0014781	1585,7	3,5774	0,0014732	1584,3	3,5728	0,0014684	1583,0	3,5682	0,0014638	1581,7	3,5638
355	0,001502	1614,3	3,6231	0,001497	1612,7	3,6181	0,001492	1611,2	3,6133	0,001486	1609,7	3,6085
360	0,001529	1643,6	3,6695	0,001522	1641,7	3,6641	0,001516	1639,9	3,6589	0,001511	1638,2	3,6538
365	0,001557	1673,6	3,7167	0,001550	1671,5	3,7109	0,001543	1669,4	3,7052	0,001537	1667,4	3,6997
370	0,001588	1704,5	3,7649	0,001580	1702,0	3,7585	0,001572	1699,6	3,7524	0,001565	1697,3	3,7464
375	0,001622	1736,3	3,8142	0,001613	1733,4	3,8072	0,001604	1730,6	3,8005	0,001596	1728,0	3,7939
380	0,001659	1769,3	3,8649	0,001649	1765,9	3,8571	0,001639	1762,7	3,8497	0,001630	1759,6	3,8425
385	0,001701	1803,5	3,9170	0,001689	1799,5	3,9084	0,001677	1795,8	3,9001	0,001667	1792,2	3,8922
390	0,001748	1839,2	3,9710	0,001734	1834,5	3,9613	0,001720	1830,1	3,9521	0,001707	1826,0	3,9433

t	p = 42,0 MПа			p = 43,0 MПа			p = 44,0 MПа			p = 45,0 MПа		
	v	i	s	v	i	s	v	i	s	v	i	s
395	0,001801	1876,6	4,0272	0,001784	1871,0	4,0162	0,001768	1865,8	4,0058	0,001753	1861,0	3,9960
400	0,001862	1916,0	4,0860	0,001841	1909,3	4,0734	0,001821	1903,2	4,0616	0,001804	1897,6	4,0505
405	0,001932	1957,8	4,1478	0,001906	1949,8	4,1332	0,001883	1942,5	4,1197	0,001861	1935,8	4,1071
410	0,002014	2002,4	4,2133	0,001982	1992,7	4,1963	0,001953	1984,0	4,1806	0,001926	1976,0	4,1661
415	0,002111	2050,2	4,2830	0,002070	2038,4	4,2630	0,002034	2027,9	4,2447	0,002001	2018,4	4,2280
420	0,002226	2101,5	4,3574	0,002174	2087,3	4,3337	0,002128	2074,6	4,3124	0,002088	2063,3	4,2930
425	0,002363	2156,5	4,4365	0,002295	2139,4	4,4086	0,002238	2124,3	4,3837	0,002187	2110,8	4,3612
430	0,002522	2214,8	4,5196	0,002437	2194,6	4,4874	0,002365	2176,7	4,4586	0,002302	2160,9	4,4327
435	0,002703	2275,2	4,6052	0,002599	2252,1	4,5690	0,002510	2231,6	4,5364	0,002434	2213,3	4,5070
440	0,002902	2336,1	4,6909	0,002779	2310,9	4,6516	0,002673	2288,1	4,6158	0,002581	2267,5	4,5833
445	0,003113	2395,8	4,7744	0,002973	2369,3	4,7332	0,002850	2344,9	4,6952	0,002743	2322,5	4,6601
450	0,003328	2453,2	4,8540	0,003174	2426,2	4,8122	0,003037	2400,8	4,7728	0,002915	2377,3	4,7362
460	0,003753	2558,5	4,9986	0,003580	2532,2	4,9577	0,003421	2506,8	4,9184	0,003278	2482,6	4,8808
470	0,004156	2650,8	5,1237	0,003971	2626,3	5,0853	0,003800	2602,4	5,0479	0,003642	2579,0	5,0114
480	0,004529	2732,0	5,2322	0,004338	2709,5	5,1965	0,004159	2687,3	5,1613	0,003992	2665,4	5,1269
490	0,004875	2804,3	5,3276	0,004680	2783,8	5,2945	0,004496	2763,4	5,2617	0,004324	2743,1	5,2294
500	0,005195	2869,4	5,4124	0,004998	2850,7	5,3816	0,004811	2832,0	5,3511	0,004634	2813,4	5,3209
510	0,005494	2928,8	5,4888	0,005295	2911,7	5,4600	0,005105	2894,5	5,4314	0,004925	2877,3	5,4030
520	0,005775	2983,8	5,5585	0,005573	2967,9	5,5313	0,005381	2952,0	5,5044	0,005199	2936,1	5,4776
530	0,006041	3035,0	5,6227	0,005837	3020,3	5,5970	0,005643	3005,5	5,5714	0,005458	2990,7	5,5461
540	0,006293	3083,3	5,6824	0,006087	3069,5	5,6579	0,005891	3055,7	5,6335	0,005704	3041,9	5,6094
550	0,006535	3128,9	5,7382	0,006326	3116,0	5,7148	0,006127	3103,1	5,6915	0,005938	3090,2	5,6685
560	0,006766	3172,5	5,7908	0,006555	3160,3	5,7683	0,006354	3148,2	5,7459	0,006163	3136,0	5,7238
570	0,006988	3214,2	5,8406	0,006775	3202,8	5,8189	0,006572	3191,3	5,7974	0,006379	3179,8	5,7761
580	0,007203	3254,4	5,8880	0,006988	3243,5	5,8670	0,006782	3232,7	5,8462	0,006587	3221,8	5,8256
590	0,007411	3293,2	5,9332	0,007193	3282,9	5,9128	0,006986	3272,6	5,8927	0,006788	3262,3	5,8728
600	0,007614	3330,9	5,9766	0,007393	3321,1	5,9568	0,007183	3311,3	5,9372	0,006983	3301,5	5,9179
610	0,007810	3367,5	6,0184	0,007587	3358,2	5,9991	0,007375	3348,9	5,9800	0,007172	3339,5	5,9612
620	0,008002	3403,3	6,0586	0,007777	3394,4	6,0398	0,007562	3385,4	6,0212	0,007357	3376,5	6,0029
630	0,008189	3438,2	6,0975	0,007961	3429,7	6,0791	0,007744	3421,2	6,0610	0,007537	3412,6	6,0431
640	0,008372	3472,5	6,1352	0,008142	3464,3	6,1172	0,007922	3456,1	6,0995	0,007713	3447,9	6,0820
650	0,008552	3506,1	6,1718	0,008319	3498,2	6,1542	0,008097	3490,4	6,1368	0,007885	3482,5	6,1197
660	0,008728	3539,1	6,2074	0,008492	3531,6	6,1901	0,008268	3524,0	6,1731	0,008053	3516,5	6,1562
670	0,008900	3571,6	6,2421	0,008662	3564,4	6,2251	0,008435	3557,1	6,2083	0,008219	3549,9	6,1918
680	0,009070	3603,6	6,2758	0,008830	3596,7	6,2591	0,008600	3589,7	6,2427	0,008381	3582,7	6,2265
690	0,009237	3635,2	6,3088	0,008994	3628,5	6,2924	0,008762	3621,8	6,2762	0,008541	3615,1	6,2602
700	0,009402	3666,4	6,3411	0,009156	3660,0	6,3249	0,008922	3653,5	6,3089	0,008698	3647,0	6,2932
710	0,009564	3697,3	6,3726	0,009316	3691,0	6,3566	0,009079	3684,8	6,3409	0,008853	3678,5	6,3254
720	0,009724	3727,8	6,4035	0,009473	3721,8	6,3878	0,009234	3715,7	6,3723	0,009005	3709,7	6,3570
730	0,009882	3758,1	6,4338	0,009628	3752,2	6,4183	0,009386	3746,4	6,4029	0,009156	3740,5	6,3879
740	0,010038	3788,0	6,4635	0,009781	3782,4	6,4482	0,009537	3776,7	6,4331	0,009304	3771,1	6,4182
750	0,01019	3817,8	6,4927	0,009933	3812,3	6,4775	0,009686	3806,8	6,4626	0,009451	3801,3	6,4479
760	0,01034	3847,3	6,5214	0,010083	3842,0	6,5064	0,009834	3836,7	6,4916	0,009596	3831,4	6,4771
770	0,01050	3876,6	6,5496	0,01023	3871,4	6,5348	0,009979	3866,3	6,5202	0,009739	3861,1	6,5058
780	0,01064	3905,7	6,5774	0,01038	3900,7	6,5627	0,010123	3895,7	6,5482	0,009881	3890,7	6,5340

t	p = 42,0 MPa			p = 43,0 MPa			p = 44,0 MPa			p = 45,0 MPa		
	v	i	s	v	i	s	v	i	s	v	i	s
790	0,01079	3934,6	6,6048	0,01052	3929,8	6,5902	0,01027	3924,9	6,5758	0,010021	3920,1	6,5618
800	0,01094	3963,4	6,6317	0,01067	3958,7	6,6172	0,01041	3954,0	6,6030	0,01016	3949,3	6,5891

3-jadval (davomi)

t	p = 46,0 MPa			p = 47,0 MPa			p = 48,0 MPa			p = 49,0 MPa		
	v	i	s	v	i	s	v	i	s	v	i	s
0	0,0009785	45,3	- 0,0007	0,0009780	46,3	- 0,0008	0,0009776	47,2	- 0,0008	0,0009772	48,2	- 0,0009
10	0,0009798	85,8	0,1447	0,0009794	86,7	0,1445	0,0009790	87,6	0,1444	0,0009786	88,5	0,1442
20	0,0009821	126,3	0,2856	0,0009817	127,2	0,2853	0,0009813	128,2	0,2851	0,0009809	129,1	0,2848
30	0,0009851	167,0	0,4221	0,0009847	167,9	0,4218	0,0009843	168,8	0,4214	0,0009839	169,7	0,4211
40	0,0009887	207,8	0,5544	0,0009883	208,7	0,5540	0,0009879	209,5	0,5536	0,0009875	210,4	0,5532
50	0,0009929	248,6	0,6828	0,0009926	249,5	0,6823	0,0009922	250,3	0,6819	0,0009918	251,2	0,6814
60	0,0009977	289,5	0,8074	0,0009973	290,4	0,8069	0,0009969	291,2	0,8064	0,0009965	292,0	0,8059
70	0,0010030	330,5	0,9286	0,0010026	331,3	0,9280	0,0010022	332,1	0,9275	0,0010018	332,9	0,9269
80	0,0010088	371,5	1,0464	0,0010084	372,3	1,0458	0,0010080	373,1	1,0452	0,0010076	373,9	1,0446
90	0,0010151	412,6	1,1612	0,0010147	413,4	1,1606	0,0010143	414,2	1,1599	0,0010138	415,0	1,1593
100	0,0010219	453,8	1,2731	0,0010214	454,6	1,2724	0,0010210	455,3	1,2717	0,0010206	456,1	1,2710
110	0,0010291	495,1	1,3823	0,0010286	495,9	1,3815	0,0010282	496,6	1,3808	0,0010277	497,3	1,3800
120	0,0010368	536,5	1,4889	0,0010363	537,2	1,4881	0,0010359	538,0	1,4873	0,0010354	538,7	1,4866
130	0,0010450	578,0	1,5932	0,0010445	578,7	1,5924	0,0010440	579,4	1,5915	0,0010435	580,1	1,5907
140	0,0010537	619,7	1,6952	0,0010532	620,3	1,6943	0,0010527	621,0	1,6934	0,0010522	621,7	1,6925
150	0,0010629	661,4	1,7952	0,0010624	662,1	1,7942	0,0010619	662,8	1,7933	0,0010613	663,4	1,7923
160	0,0010727	703,4	1,8931	0,0010721	704,0	1,8921	0,0010716	704,7	1,8911	0,0010710	705,3	1,8901
170	0,0010830	745,5	1,9893	0,0010824	746,1	1,9882	0,0010818	746,7	1,9872	0,0010812	747,4	1,9861
180	0,0010940	787,9	2,0838	0,0010933	788,4	2,0826	0,0010927	789,0	2,0815	0,0010920	789,6	2,0804
190	0,0011056	830,4	2,1766	0,0011049	831,0	2,1754	0,0011042	831,5	2,1743	0,0011035	832,1	2,1731
200	0,0011178	873,2	2,2681	0,0011171	873,7	2,2668	0,0011163	874,3	2,2656	0,0011156	874,8	2,2643
210	0,0011308	916,3	2,3582	0,0011300	916,8	2,3569	0,0011292	917,3	2,3555	0,0011284	917,8	2,3542
220	0,0011446	959,7	2,4471	0,0011437	960,2	2,4457	0,0011429	960,6	2,4443	0,0011420	961,1	2,4429
230	0,0011593	1003,5	2,5350	0,0011583	1003,9	2,5335	0,0011574	1004,3	2,5320	0,0011565	1004,7	2,5305
240	0,0011749	1047,6	2,6219	0,0011739	1048,0	2,6203	0,0011728	1048,3	2,6187	0,0011718	1048,7	2,6171
250	0,0011916	1092,2	2,7080	0,0011904	1092,5	2,7062	0,0011893	1092,8	2,7045	0,0011882	1093,1	2,7028
260	0,0012094	1137,4	2,7934	0,0012082	1137,6	2,7915	0,0012069	1137,8	2,7897	0,0012057	1138,0	2,7879
270	0,0012286	1183,0	2,8783	0,0012272	1183,2	2,8763	0,0012258	1183,3	2,8743	0,0012244	1183,5	2,8724
280	0,0012492	1229,4	2,9628	0,0012476	1229,4	2,9606	0,0012461	1229,5	2,9585	0,0012446	1229,6	2,9564
290	0,0012715	1276,4	3,0471	0,0012697	1276,4	3,0447	0,0012680	1276,3	3,0425	0,0012663	1276,3	3,0402
300	0,0012957	1324,3	3,1313	0,0012937	1324,1	3,1288	0,0012917	1324,0	3,1263	0,0012898	1323,9	3,1238
310	0,0013221	1373,0	3,2157	0,0013199	1372,8	3,2129	0,0013176	1372,5	3,2102	0,0013154	1372,2	3,2075
320	0,0013512	1422,9	3,3004	0,0013485	1422,4	3,2974	0,0013459	1422,0	3,2944	0,0013434	1421,6	3,2915
330	0,0013832	1473,9	3,3858	0,0013802	1473,3	3,3824	0,0013771	1472,7	3,3791	0,0013742	1472,1	3,3758
340	0,0014190	1526,4	3,4720	0,0014154	1525,5	3,4683	0,0014118	1524,7	3,4646	0,0014083	1523,8	3,4609
350	0,0014593	1580,5	3,5595	0,0014549	1579,3	3,5552	0,0014506	1578,1	3,5511	0,0014465	1577,0	3,5470
355	0,001481	1608,2	3,6039	0,001477	1606,9	3,5994	0,001472	1605,6	3,5949	0,001467	1604,3	3,5906
360	0,001505	1636,6	3,6488	0,001500	1635,0	3,6439	0,001495	1633,5	3,6392	0,001490	1632,0	3,6345

t	p = 46,0 MPa			p = 47,0 MPa			p = 48,0 MPa			p = 49,0 MPa		
	v	i	s	v	i	s	v	i	s	v	i	s
365	0,001531	1665,5	3,6943	0,001525	1663,7	3,6891	0,001519	1662,0	3,6840	0,001513	1660,3	3,6790
370	0,001558	1695,1	3,7406	0,001552	1693,1	3,7349	0,001545	1691,1	3,7294	0,001539	1689,2	3,7241
375	0,001588	1725,5	3,7876	0,001581	1723,1	3,7815	0,001573	1720,9	3,7756	0,001566	1718,7	3,7698
380	0,001621	1756,7	3,8356	0,001612	1754,0	3,8289	0,001604	1751,4	3,8225	0,001596	1748,9	3,8162
385	0,001656	1788,9	3,8846	0,001646	1785,7	3,8773	0,001637	1782,7	3,8703	0,001628	1779,9	3,8635
390	0,001695	1822,1	3,9349	0,001684	1818,4	3,9269	0,001673	1815,0	3,9191	0,001663	1811,7	3,9117
395	0,001739	1856,5	3,9866	0,001726	1852,3	3,9777	0,001713	1848,3	3,9691	0,001702	1844,5	3,9609
400	0,001787	1892,3	4,0400	0,001772	1887,4	4,0300	0,001757	1882,7	4,0205	0,001744	1878,4	4,0115
405	0,001841	1929,6	4,0952	0,001823	1923,9	4,0840	0,001806	1918,5	4,0734	0,001790	1913,5	4,0634
410	0,001903	1968,7	4,1526	0,001881	1962,0	4,1400	0,001861	1955,7	4,1281	0,001842	1949,9	4,1169
415	0,001972	2009,8	4,2125	0,001946	2001,9	4,1982	0,001922	1994,6	4,1848	0,001900	1987,8	4,1722
420	0,002052	2053,0	4,2752	0,002020	2043,7	4,2588	0,001991	2035,2	4,2436	0,001965	2027,3	4,2294
425	0,002143	2098,7	4,3407	0,002104	2087,7	4,3220	0,002069	2077,7	4,3047	0,002037	2068,6	4,2887
430	0,002248	2146,7	4,4093	0,002200	2133,9	4,3879	0,002157	2122,3	4,3683	0,002119	2111,7	4,3502
435	0,002367	2196,9	4,4804	0,002309	2182,1	4,4563	0,002257	2168,7	4,4342	0,002212	2156,6	4,4138
440	0,002501	2248,9	4,5537	0,002431	2232,2	4,5267	0,002369	2217,0	4,5020	0,002315	2203,2	4,4794
445	0,002649	2302,1	4,6280	0,002566	2283,5	4,5985	0,002493	2266,6	4,5713	0,002429	2251,1	4,5464
450	0,002808	2355,5	4,7021	0,002713	2335,4	4,6705	0,002629	2317,0	4,6413	0,002554	2300,0	4,6143
460	0,003148	2459,6	4,8450	0,003031	2437,9	4,8112	0,002926	2417,5	4,7793	0,002831	2398,4	4,7493
470	0,003497	2556,3	4,9761	0,003363	2534,5	4,9421	0,003241	2513,6	4,9095	0,003129	2493,6	4,8784
480	0,003837	2644,0	5,0932	0,003692	2623,1	5,0605	0,003558	2602,7	5,0286	0,003434	2582,9	4,9977
490	0,004161	2723,0	5,1975	0,004008	2703,2	5,1663	0,003866	2683,9	5,1357	0,003733	2664,9	5,1059
500	0,004467	2794,8	5,2910	0,004310	2776,4	5,2615	0,004161	2758,2	5,2324	0,004021	2740,2	5,2039
510	0,004755	2860,1	5,3750	0,004594	2843,1	5,3472	0,004441	2826,1	5,3198	0,004297	2809,3	5,2928
520	0,005026	2920,2	5,4512	0,004862	2904,4	5,4250	0,004706	2888,6	5,3991	0,004558	2872,9	5,3735
530	0,005283	2975,9	5,5210	0,005116	2961,2	5,4962	0,004957	2946,5	5,4716	0,004806	2931,8	5,4473
540	0,005526	3028,1	5,5856	0,005357	3014,3	5,5619	0,005196	3000,5	5,5385	0,005042	2986,8	5,5153
550	0,005758	3077,3	5,6457	0,005587	3064,3	5,6231	0,005423	3051,4	5,6007	0,005267	3038,5	5,5786
560	0,005981	3123,9	5,7020	0,005807	3111,7	5,6803	0,005641	3099,6	5,6588	0,005483	3087,5	5,6376
570	0,006194	3168,4	5,7550	0,006018	3156,9	5,7342	0,005850	3145,4	5,7135	0,005690	3134,0	5,6931
580	0,006400	3211,0	5,8053	0,006222	3200,1	5,7852	0,006052	3189,3	5,7653	0,005889	3178,5	5,7456
590	0,006599	3252,0	5,8531	0,006419	3241,7	5,8336	0,006246	3231,4	5,8144	0,006082	3221,2	5,7954
600	0,006792	3291,7	5,8988	0,006609	3281,9	5,8799	0,006435	3272,1	5,8613	0,006268	3262,4	5,8428
610	0,006979	3330,2	5,9426	0,006794	3320,8	5,9243	0,006618	3311,5	5,9061	0,006449	3302,2	5,8882
620	0,007161	3367,6	5,9848	0,006974	3358,7	5,9669	0,006796	3349,8	5,9492	0,006625	3340,9	5,9318
630	0,007339	3404,1	6,0254	0,007150	3395,6	6,0080	0,006969	3387,1	5,9907	0,006796	3378,6	5,9737
640	0,007513	3439,8	6,0647	0,007321	3431,6	6,0476	0,007139	3423,5	6,0308	0,006964	3415,3	6,0142
650	0,007682	3474,7	6,1027	0,007489	3466,9	6,0861	0,007304	3459,1	6,0696	0,007127	3451,3	6,0533
660	0,007849	3509,0	6,1397	0,007653	3501,5	6,1233	0,007466	3494,0	6,1072	0,007287	3486,5	6,0912
670	0,008012	3542,6	6,1755	0,007814	3535,4	6,1595	0,007625	3528,2	6,1437	0,007444	3521,0	6,1280
680	0,008172	3575,8	6,2105	0,007972	3568,8	6,1947	0,007781	3561,9	6,1792	0,007598	3554,9	6,1638
690	0,008329	3608,4	6,2445	0,008127	3601,7	6,2290	0,007934	3595,0	6,2137	0,007749	3588,3	6,1987
700	0,008484	3640,5	6,2777	0,008280	3634,1	6,2625	0,008084	3627,6	6,2475	0,007897	3621,2	6,2326
710	0,008637	3672,3	6,3102	0,008430	3666,1	6,2952	0,008233	3659,8	6,2804	0,008043	3653,6	6,2658
720	0,008787	3703,7	6,3420	0,008578	3697,7	6,3272	0,008378	3691,6	6,3126	0,008187	3685,6	6,2982

t	p = 46,0 Mlla			p = 47,0 Mlla			p = 48,0 Mlla			p = 49,0 Mlla		
	v	i	s	v	i	s	v	i	s	v	i	s
730	0,008935	3734,7	6,3731	0,008724	3728,9	6,3585	0,008522	3723,1	6,3441	0,008329	3717,3	6,3299
740	0,009081	3765,4	6,4035	0,008868	3759,8	6,3891	0,008664	3754,2	6,3749	0,008469	3748,6	6,3609
750	0,009226	3795,9	6,4334	0,009010	3790,4	6,4192	0,008804	3785,0	6,4052	0,008607	3779,6	6,3914
760	0,009368	3826,1	6,4628	0,009151	3820,8	6,4487	0,008943	3815,5	6,4349	0,008743	3810,2	6,4212
770	0,009509	3856,0	6,4916	0,009290	3850,9	6,4777	0,009079	3845,8	6,4640	0,008878	3840,7	6,4505
780	0,009649	3885,7	6,5200	0,009427	3880,8	6,5062	0,009215	3875,8	6,4927	0,009011	3870,9	6,4793
790	0,009787	3915,3	6,5479	0,009563	3910,4	6,5343	0,009348	3905,6	6,5209	0,009143	3900,8	6,5076
800	0,009924	3944,6	6,5754	0,009697	3939,9	6,5619	0,009481	3935,3	6,5486	0,009273	3930,6	6,5355

3-jadval (davomi)

t	p = 50,0 Mlla			p = 52,0 Mlla			p = 54,0 Mlla			p = 56,0 Mlla		
	v	i	s	v	i	s	v	i	s	v	i	s
0	0,0009767	49,1	-0,0010	0,0009759	51,0	-0,0012	0,0009750	52,9	-0,0014	0,0009742	54,8	-0,0016
10	0,0009782	89,5	0,1440	0,0009773	91,3	0,1436	0,0009765	93,1	0,1432	0,0009757	95,0	0,1428
20	0,0009805	130,0	0,2845	0,0009797	131,8	0,2840	0,0009789	133,6	0,2835	0,0009781	135,4	0,2829
30	0,0009835	170,6	0,4208	0,0009827	172,3	0,4201	0,0009819	174,1	0,4194	0,0009812	175,8	0,4187
40	0,0009872	211,3	0,5528	0,0009864	213,0	0,5521	0,0009856	214,7	0,5513	0,0009849	216,4	0,5505
50	0,0009914	252,0	0,6810	0,0009906	253,7	0,6801	0,0009899	255,4	0,6792	0,0009891	257,1	0,6783
60	0,0009962	292,9	0,8054	0,0009954	294,5	0,8044	0,0009946	296,2	0,8034	0,0009938	297,8	0,8024
70	0,0010014	333,8	0,9264	0,0010006	335,4	0,9253	0,0009999	337,0	0,9242	0,0009991	338,6	0,9231
80	0,0010072	374,7	1,0440	0,0010064	376,3	1,0428	0,0010056	377,9	1,0416	0,0010048	379,5	1,0404
90	0,0010134	415,7	1,1586	0,0010126	417,3	1,1573	0,0010118	418,9	1,1560	0,0010110	420,4	1,1547
100	0,0010201	456,9	1,2703	0,0010193	458,4	1,2689	0,0010184	459,9	1,2675	0,0010176	461,4	1,2662
110	0,0010273	498,1	1,3793	0,0010264	499,6	1,3778	0,0010255	501,1	1,3764	0,0010247	502,6	1,3749
120	0,0010349	539,4	1,4858	0,0010340	540,9	1,4842	0,0010331	542,3	1,4826	0,0010322	543,8	1,4811
130	0,0010431	580,8	1,5898	0,0010421	582,3	1,5882	0,0010411	583,7	1,5865	0,0010402	585,1	1,5849
140	0,0010517	622,4	1,6917	0,0010507	623,8	1,6899	0,0010496	625,1	1,6881	0,0010487	626,5	1,6864
150	0,0010608	664,1	1,7914	0,0010597	665,4	1,7895	0,0010587	666,8	1,7877	0,0010576	668,1	1,7858
160	0,0010704	706,0	1,8891	0,0010693	707,2	1,8872	0,0010682	708,5	1,8852	0,0010671	709,8	1,8833
170	0,0010806	748,0	1,9851	0,0010794	749,2	1,9830	0,0010782	750,5	1,9809	0,0010771	751,7	1,9788
180	0,0010914	790,2	2,0793	0,0010901	791,4	2,0771	0,0010889	792,6	2,0749	0,0010876	793,8	2,0727
190	0,0011028	832,6	2,1719	0,0011014	833,8	2,1696	0,0011001	834,9	2,1673	0,0010988	836,0	2,1650
200	0,0011149	875,3	2,2631	0,0011134	876,4	2,2606	0,0011120	877,4	2,2582	0,0011105	878,5	2,2557
210	0,0011276	918,3	2,3529	0,0011261	919,2	2,3503	0,0011245	920,2	2,3477	0,0011230	921,2	2,3451
220	0,0011412	961,5	2,4415	0,0011395	962,4	2,4387	0,0011378	963,3	2,4360	0,0011361	964,3	2,4332
230	0,0011555	1005,1	2,5290	0,0011537	1005,9	2,5260	0,0011519	1006,8	2,5231	0,0011501	1007,6	2,5202
240	0,0011708	1049,0	2,6155	0,0011688	1049,8	2,6124	0,0011668	1050,5	2,6093	0,0011649	1051,3	2,6062
250	0,0011871	1093,4	2,7012	0,0011849	1094,1	2,6978	0,0011827	1094,7	2,6945	0,0011806	1095,4	2,6913
260	0,0012045	1138,3	2,7861	0,0012020	1138,8	2,7825	0,0011997	1139,3	2,7790	0,0011973	1139,9	2,7755
270	0,0012231	1183,7	2,8704	0,0012204	1184,0	2,8666	0,0012178	1184,4	2,8628	0,0012152	1184,9	2,8591
280	0,0012431	1229,7	2,9543	0,0012401	1229,9	2,9502	0,0012372	1230,1	2,9462	0,0012343	1230,4	2,9422
290	0,0012646	1276,3	3,0379	0,0012613	1276,4	3,0335	0,0012580	1276,4	3,0291	0,0012548	1276,5	3,0248
300	0,0012879	1323,7	3,1214	0,0012841	1323,6	3,1166	0,0012805	1323,4	3,1119	0,0012769	1323,3	3,1072
310	0,0013132	1372,0	3,2049	0,0013090	1371,6	3,1996	0,0013048	1371,2	3,1945	0,0013008	1370,9	3,1895

t	p = 50,0 MIta			p = 52,0 MIta			p = 54,0 MIta			p = 56,0 MIta		
	v	i	s	v	i	s	v	i	s	v	i	s
320	0,0013409	1421,2	3,2885	0,0013360	1420,5	3,2828	0,0013313	1419,9	3,2772	0,0013267	1419,3	3,2718
330	0,0013713	1471,5	3,3726	0,0013656	1470,5	3,3663	0,0013602	1469,5	3,3602	0,0013549	1468,6	3,3542
340	0,0014049	1523,1	3,4574	0,0013983	1521,6	3,4504	0,0013920	1520,2	3,4436	0,0013859	1518,9	3,4370
350	0,0014424	1576,0	3,5430	0,0014346	1574,0	3,5352	0,0014272	1572,2	3,5276	0,0014201	1570,5	3,5203
355	0,001463	1603,1	3,5863	0,001454	1600,8	3,5780	0,001446	1598,7	3,5700	0,001439	1596,7	3,5623
360	0,001485	1630,6	3,6300	0,001475	1628,0	3,6212	0,001466	1625,6	3,6127	0,001458	1623,3	3,6045
365	0,001508	1658,7	3,6742	0,001498	1655,7	3,6647	0,001488	1652,9	3,6557	0,001479	1650,4	3,6470
370	0,001533	1687,3	3,7189	0,001521	1683,9	3,7088	0,001511	1680,8	3,6992	0,001501	1677,8	3,6899
375	0,001560	1716,6	3,7642	0,001547	1712,7	3,7533	0,001535	1709,1	3,7430	0,001524	1705,8	3,7332
380	0,001588	1746,5	3,8101	0,001574	1742,1	3,7985	0,001561	1738,0	3,7874	0,001549	1734,2	3,7769
385	0,001620	1777,1	3,8569	0,001604	1772,1	3,8443	0,001589	1767,5	3,8324	0,001575	1763,2	3,8211
390	0,001654	1808,6	3,9045	0,001635	1802,8	3,8908	0,001619	1797,6	3,8780	0,001604	1792,8	3,8659
395	0,001690	1841,0	3,9531	0,001670	1834,4	3,9382	0,001651	1828,4	3,9243	0,001634	1823,0	3,9112
400	0,001731	1874,3	4,0028	0,001707	1866,8	3,9865	0,001686	1860,0	3,9714	0,001667	1853,9	3,9573
405	0,001775	1908,8	4,0538	0,001748	1900,2	4,0359	0,001724	1892,4	4,0194	0,001702	1885,5	4,0041
410	0,001825	1944,5	4,1063	0,001793	1934,6	4,0865	0,001766	1925,8	4,0684	0,001741	1917,9	4,0518
415	0,001879	1981,5	4,1-603	0,001843	1970,2	4,1384	0,001811	1960,2	4,1186	0,001783	1951,3	4,1004
420	0,001940	2020,1	4,2161	0,001898	2007,0	4,1918	0,001861	1995,6	4,1699	0,001828	1985,5	4,1500
425	0,002009	2060,2	4,2738	0,001958	2045,2	4,2467	0,001915	2032,2	4,2225	0,001878	2020,8	4,2007
430	0,002085	2102,0	4,3334	0,002025	2084,8	4,3032	0,001975	2070,0	4,2765	0,001932	2057,1	4,2525
435	0,002171	2145,5	4,3950	0,002100	2125,9	4,3613	0,002041	2109,1	4,3318	0,001992	2094,5	4,3055
440	0,002266	2190,5	4,4585	0,002183	2168,3	4,4211	0,002114	2149,4	4,3885	0,002057	2133,0	4,3597
445	0,002372	2237,0	4,5233	0,002274	2212,1	4,4822	0,002194	2190,8	4,4464	0,002128	2172,5	4,4149
450	0,002487	2284,4	4,5892	0,002374	2256,9	4,5444	0,002282	2233,3	4,5054	0,002205	2213,0	4,4711
460	0,002745	2380,5	4,7212	0,002599	2348,4	4,6701	0,002479	2320,6	4,6252	0,002379	2296,4	4,5856
470	0,003027	2474,7	4,8488	0,002849	2439,8	4,7939	0,002701	2408,8	4,7447	0,002577	2381,3	4,7006
480	0,003319	2563,9	4,9680	0,003114	2528,0	4,9118	0,002941	2495,3	4,8603	0,002794	2465,7	4,8134
490	0,003609	2646,6	5,0770	0,003384	2611,2	5,0215	0,003190	2578,1	4,9696	0,003022	2547,5	4,9213
500	0,003889	2722,5	5,1759	0,003650	2688,4	5,1220	0,003440	2656,1	5,0712	0,003255	2625,5	5,0229
510	0,004160	2792,7	5,2661	0,003909	2760,1	5,2143	0,003685	2728,8	5,1645	0,003487	2698,9	5,1172
520	0,004417	2857,4	5,3482	0,004158	2826,7	5,2987	0,003924	2796,8	5,2508	0,003715	2767,9	5,2048
530	0,004662	2917,2	5,4232	0,004396	2888,4	5,3761	0,004155	2860,2	5,3302	0,003937	2832,6	5,2858
540	0,004896	2973,2	5,4924	0,004623	2946,0	5,4474	0,004376	2919,3	5,4035	0,004151	2893,2	5,3608
550	0,005118	3025,7	5,5566	0,004841	3000,2	5,5135	0,004588	2975,0	5,4714	0,004357	2950,1	5,4304
560	0,005332	3075,4	5,6166	0,005050	3051,3	5,5753	0,004792	3027,5	5,5349	0,004556	3003,9	5,4954
570	0,005537	3122,6	5,6729	0,005250	3099,8	5,6332	0,004987	3077,3	5,5943	0,004747	3055,0	5,5563
580	0,005734	3167,7	5,7261	0,005443	3146,1	5,6878	0,005176	3124,8	5,6503	0,004931	3103,6	5,6136
590	0,005924	3210,9	5,7765	0,005629	3190,5	5,7395	0,005359	3170,2	5,7032	0,005110	3150,1	5,6678
600	0,006109	3252,6	5,8245	0,005810	3233,2	5,7886	0,005535	3213,9	5,7535	0,005282	3194,7	5,7192
610	0,006288	3292,9	5,8705	0,005984	3274,4	5,8356	0,005706	3256,0	5,8015	0,005449	3237,7	5,7682
620	0,006461	3332,0	5,9145	0,006154	3314,4	5,8806	0,005872	3296,8	5,8474	0,005612	3279,3	5,8150
630	0,006631	3370,1	5,9569	0,006320	3353,2	5,9238	0,006034	3336,4	5,8915	0,005770	3319,7	5,8600
640	0,006796	3407,2	5,9977	0,006481	3391,0	5,9655	0,006191	3374,9	5,9340	0,005924	3358,9	5,9032
650	0,006957	3443,5	6,0372	0,006639	3427,9	6,0057	0,006345	3412,5	5,9749	0,006074	3397,1	5,9448
660	0,007115	3479,0	6,0755	0,006793	3464,1	6,0446	0,006496	3449,2	6,0145	0,006221	3434,5	5,9850

t	p = 50,0 MIIa			p = 52,0 MIIa			p = 54,0 MIIa			p = 56,0 MIIa		
	v	i	s	v	i	s	v	i	s	v	i	s
670	0,007270	3513,8	6,1126	0,006944	3499,5	6,0823	0,006643	3485,2	6,0528	0,006365	3471,0	6,0240
680	0,007422	3548,0	6,1487	0,007092	3534,2	6,1190	0,006788	3520,5	6,0900	0,006506	3506,8	6,0618
690	0,007571	3581,6	6,1838	0,007237	3568,3	6,1546	0,006929	3555,1	6,1262	0,006645	3542,0	6,0984
700	0,007718	3614,8	6,2180	0,007380	3601,9	6,1893	0,007069	3589,2	6,1614	0,006780	3576,5	6,1341
710	0,007862	3647,4	6,2514	0,007520	3635,0	6,2232	0,007205	3622,7	6,1957	0,006914	3610,5	6,1689
720	0,008004	3679,6	6,2840	0,007659	3667,7	6,2562	0,007340	3655,8	6,2291	0,007045	3644,0	6,2028
730	0,008143	3711,5	6,3159	0,007795	3699,9	6,2885	0,007473	3688,4	6,2618	0,007175	3677,0	6,2358
740	0,008281	3743,0	6,3471	0,007929	3731,8	6,3201	0,007603	3720,7	6,2938	0,007302	3709,6	6,2682
750	0,008417	3774,1	6,3777	0,008061	3763,3	6,3511	0,007732	3752,6	6,3251	0,007428	3741,9	6,2998
760	0,008552	3805,0	6,4078	0,008192	3794,5	6,3814	0,007859	3784,1	6,3558	0,007552	3773,7	6,3309
770	0,008685	3835,6	6,4372	0,008321	3825,4	6,4112	0,007985	3815,3	6,3859	0,007674	3805,3	6,3613
780	0,008816	3865,9	6,4662	0,008449	3856,1	6,4404	0,008109	3846,3	6,4154	0,007795	3836,6	6,3911
790	0,008946	3896,0	6,4946	0,008575	3886,5	6,4692	0,008232	3877,0	6,4445	0,007914	3867,6	6,4204
800	0,009074	3926,0	6,5226	0,008699	3916,7	6,4975	0,008353	3907,5	6,4730	0,008032	3898,3	6,4492

3-jadval (davomi)

t	p = 58,0 MIIa			p = 60,0 MIIa			p = 62,0 MIIa			p = 64,0 M		
	v	i	s	v	i	s	v	i	s	v	i	s
0	0,0009733	56,7	-0,0018	0,0009725	58,6	-0,0021	0,0009716	60,5	-0,0023	0,0009708	62,3	-0,0026
10	0,0009749	96,8	0,1424	0,0009741	98,7	0,1420	0,0009733	100,5	0,1416	0,0009725	102,3	0,1412
20	0,0009773	137,1	0,2824	0,0009765	138,9	0,2818	0,0009758	140,7	0,2812	0,0009750	142,5	0,2807
30	0,0009804	177,6	0,4181	0,0009796	179,4	0,4174	0,0009789	181,1	0,4167	0,0009781	182,9	0,4160
40	0,0009841	218,2	0,5497	0,0009833	219,9	0,5489	0,0009826	221,6	0,5481	0,0009818	223,3	0,5473
50	0,0009883	258,8	0,6774	0,0009876	260,5	0,6765	0,0009868	262,2	0,6756	0,0009861	263,8	0,6747
60	0,0009931	299,5	0,8014	0,0009923	301,1	0,8004	0,0009916	302,8	0,7994	0,0009908	304,4	0,7984
70	0,0009983	340,2	0,9220	0,0009975	341,9	0,9209	0,0009968	343,5	0,9198	0,0009960	345,1	0,9187
80	0,0010040	381,1	1,0393	0,0010032	382,7	1,0381	0,0010024	384,3	1,0369	0,0010016	385,8	1,0357
90	0,0010101	422,0	1,1535	0,0010093	423,5	1,1522	0,0010085	425,1	1,1509	0,0010077	426,7	1,1497
100	0,0010167	463,0	1,2648	0,0010159	464,5	1,2634	0,0010151	466,0	1,2621	0,0010143	467,5	1,2607
110	0,0010238	504,0	1,3734	0,0010229	505,5	1,3720	0,0010221	507,0	1,3705	0,0010212	508,5	1,3691
120	0,0010313	545,2	1,4795	0,0010304	546,7	1,4780	0,0010295	548,1	1,4764	0,0010286	549,6	1,4749
130	0,0010392	586,5	1,5832	0,0010383	587,9	1,5816	0,0010374	589,3	1,5800	0,0010364	590,8	1,5783
140	0,0010477	627,9	1,6847	0,0010467	629,3	1,6829	0,0010457	630,7	1,6812	0,0010447	632,0	1,6795
150	0,0010566	669,4	1,7840	0,0010555	670,8	1,7822	0,0010545	n72,1	1,7803	0,0010535	673,5	1,7785
160	0,0010660	711,1	1,8813	0,0010649	712,4	1,8794	0,0010638	713,7	1,8775	0,0010627	715,0	1,8756
170	0,0010759	752,9	1,9768	0,0010748	754,2	1,9748	0,0010736	755,4	1,9727	0,0010725	756,7	1,9707
180	0,0010864	795,0	2,0705	0,0010852	796,2	2,0684	0,0010839	797,4	2,0663	0,0010827	798,6	2,0642
190	0,0010974	837,2	2,1627	0,0010961	838,3	2,1604	0,0010948	839,5	2,1582	0,0010936	840,6	2,1559
200	0,0011091	879,6	2,2533	0,0011077	880,7	2,2509	0,0011063	881,8	2,2486	0,0011050	882,9	2,2462
210	0,0011215	922,3	2,3426	0,0011200	923,3	2,3400	0,0011185	924,3	2,3375	0,0011170	925,3	2,3351
220	0,0011345	965,2	2,4305	0,0011329	966,2	2,4279	0,0011313	967,1	2,4252	0,0011297	968,1	2,4226
230	0,0011483	1008,5	2,5174	0,0011466	1009,3	2,5145	0,0011449	1010,2	2,5117	0,0011432	1011,1	2,5090
240	0,0011630	1052,1	2,6032	0,0011611	1052,8	2,6002	0,0011592	1053,6	2,5972	0,0011574	1054,4	2,5943
250	0,0011785	1096,0	2,6880	0,0011764	1096,7	2,6848	0,0011744	1097,4	2,6817	0,0011724	1098,1	2,6786

t	p = 58,0 MIIa			p = 60,0 MIIa			p = 62,0 MIIa			p = 64,0 M		
	v	i	s	v	i	s	v	i	s	v	i	s
260	0,0011950	1140,4	2,7721	0,0011928	1141,0	2,7687	0,0011906	1141,6	2,7653	0,0011884	1142,2	2,7620
270	0,0012127	1185,3	2,8555	0,0012102	1185,7	2,8518	0,0012078	1186,2	2,8483	0,0012054	1186,7	2,8447
280	0,0012315	1230,7	2,9383	0,0012288	1231,0	2,9344	0,0012261	1231,3	2,9306	0,0012235	1231,7	2,9268
290	0,0012517	1276,6	3,0206	0,0012487	1276,8	3,0165	0,0012457	1277,0	3,0124	0,0012428	1277,2	3,0084
300	0,0012734	1323,3	3,1027	0,0012700	1323,3	3,0982	0,0012667	1323,3	3,0938	0,0012635	1323,3	3,0895
310	0,0012969	1370,6	3,1846	0,0012930	1370,4	3,1797	0,0012893	1370,2	3,1750	0,0012857	1370,1	3,1704
320	0,0013222	1418,7	3,2664	0,0013179	1418,3	3,2612	0,0013137	1417,9	3,2561	0,0013096	1417,5	3,2510
330	0,0013498	1467,8	3,3484	0,0013449	1467,0	3,3427	0,0013401	1466,4	3,3371	0,0013355	1465,7	3,3317
340	0,0013800	1517,8	3,4306	0,0013744	1516,7	3,4244	0,0013689	1515,7	3,4183	0,0013636	1514,8	3,4123
350	0,0014132	1568,9	3,5133	0,0014067	1567,4	3,5064	0,0014004	1566,1	3,4997	0,0013943	1564,8	3,4932
355	0,001431	1594,9	3,5548	0,001424	1593,2	3,5476	0,001417	1591,6	3,5405	0,001411	1590,2	3,5337
360	0,001450	1621,2	3,5966	0,001442	1619,3	3,5890	0,001435	1617,5	3,5816	0,001428	1615,8	3,5744
365	0,001470	1648,0	3,6387	0,001462	1645,8	3,6306	0,001454	1643,7	3,6229	0,001446	1641,8	3,6153
370	0,001491	1675,1	3,6811	0,001482	1672,6	3,6726	0,001473	1670,3	3,6644	0,001465	1668,1	3,6564
375	0,001513	1702,7	3,7238	0,001503	1699,9	3,7148	0,001494	1697,3	3,7061	0,001485	1694,8	3,6977
380	0,001537	1730,8	3,7669	0,001526	1727,6	3,7573	0,001516	1724,6	3,7481	0,001506	1721,9	3,7393
385	0,001562	1759,3	3,8104	0,001550	1755,7	3,8002	0,001539	1752,4	3,7905	0,001528	1749,3	3,7811
390	0,001589	1788,4	3,8544	0,001576	1784,3	3,8435	0,001564	1780,6	3,8332	0,001552	1777,1	3,8232
395	0,001618	1818,0	3,8990	0,001604	1813,5	3,8873	0,001590	1809,3	3,8762	0,001577	1805,4	3,8657
400	0,001649	1848,3	3,9441	0,001633	1843,1	3,9316	0,001618	1838,4	3,9198	0,001604	1834,1	3,9085
405	0,001683	1879,2	3,9898	0,001664	1873,4	3,9764	0,001648	1868,2	3,9638	0,001632	1863,3	3,9518
410	0,001718	1910,8	4,0363	0,001698	1904,4	4,0219	0,001679	1898,5	4,0083	0,001662	1893,1	3,9955
415	0,001757	1943,3	4,0836	0,001734	1936,0	4,0680	0,001713	1929,4	4,0534	0,001694	1923,4	4,0397
420	0,001799	1976,5	4,1318	0,001774	1968,4	4,1149	0,001750	1961,0	4,0992	0,001729	1954,3	4,0845
425	0,001845	2010,7	4,1808	0,001816	2001,6	4,1626	0,001789	1993,4	4,1457	0,001766	1985,9	4,1299
430	0,001895	2045,7	4,2309	0,001861	2035,5	4,2111	0,001832	2026,4	4,1928	0,001805	2018,1	4,1758
435	0,001949	2081,7	4,2819	0,001911	2070,3	4,2604	0,001877	2060,2	4,2407	0,001847	2051,0	4,2224
440	0,002007	2118,7	4,3339	0,001964	2106,0	4,3106	0,001927	2094,7	4,2893	0,001893	2084,6	4,2697
445	0,002071	2156,6	4,3869	0,002022	2142,5	4,3616	0,001979	2130,0	4,3386	0,001942	2118,8	4,3175
450	0,002140	2195,4	4,4407	0,002085	2179,8	4,4134	0,002036	2166,0	4,3886	0,001994	2153,7	4,3660
460	0,002295	2275,2	4,5503	0,002224	2256,6	4,5188	0,002163	2240,1	4,4903	0,002110	2225,4	4,4644
470	0,002472	2357,0	4,6611	0,002384	2335,4	4,6256	0,002307	2316,3	4,5935	0,002241	2299,1	4,5643
480	0,002668	2439,0	4,7707	0,002561	2415,0	4,7319	0,002468	2393,5	4,6967	0,002388	2374,1	4,6645
490	0,002877	2519,4	4,8768	0,002752	2493,8	4,8358	0,002643	2470,4	4,7982	0,002548	2449,2	4,7636
500	0,003093	2596,9	4,9777	0,002952	2570,4	4,9356	0,002828	2545,9	4,8965	0,002719	2523,4	4,8602
510	0,003312	2670,7	5,0726	0,003156	2644,0	5,0302	0,003018	2619,0	4,9904	0,002897	2595,7	4,9531
520	0,003528	2740,2	5,1607	0,003361	2713,9	5,1189	0,003212	2689,1	5,0793	0,003078	2665,5	5,0416
530	0,003740	2805,9	5,2431	0,003563	2780,2	5,2020	0,003404	2755,6	5,1627	0,003261	2732,3	5,1253
540	0,003947	2867,7	5,3195	0,003762	2842,9	5,2796	0,003594	2819,0	5,2411	0,003442	2796,1	5,2043
550	0,004147	2925,8	5,3905	0,003955	2902,1	5,3519	0,003780	2879,0	5,3145	0,003621	2856,7	5,2784
560	0,004340	2980,8	5,4569	0,004142	2958,1	5,4195	0,003961	2935,9	5,3832	0,003796	2914,4	5,3481
570	0,004526	3033,0	5,5192	0,004323	3011,3	5,4830	0,004137	2990,1	5,4478	0,003966	2969,4	5,4137
580	0,004706	3082,7	5,5778	0,004499	3062,0	5,5428	0,004308	3041,7	5,5087	0,004132	3021,9	5,4755
590	0,004880	3130,2	5,6331	0,004669	3110,5	5,5993	0,004474	3091,1	5,5663	0,004294	3072,1	5,5340
600	0,005049	3175,7	5,6856	0,004834	3157,0	5,6528	0,004635	3138,4	5,6208	0,004450	3120,2	5,5895

t	p = 58,0 MPa			p = 60,0 MPa			p = 62,0 MPa			p = 64,0 M		
	v	i	s	v	i	s	v	i	s	v	i	s
610	0,005212	3219,6	5,7356	0,004993	3201,7	5,7038	0,004791	3184,0	5,6726	0,004603	3166,5	5,6422
620	0,005371	3262,0	5,7833	0,005149	3244,8	5,7524	0,004942	3227,9	5,7221	0,004751	3211,1	5,6925
630	0,005526	3303,1	5,8291	0,005300	3286,7	5,7989	0,005090	3270,4	5,7694	0,004895	3254,3	5,7406
640	0,005676	3343,0	5,8731	0,005447	3327,3	5,8436	0,005234	3311,7	5,8148	0,005036	3296,2	5,7867
650	0,005823	3381,9	5,9154	0,005591	3366,8	5,8867	0,005375	3351,8	5,8586	0,005174	3337,0	5,8311
660	0,005967	3419,8	5,9563	0,005731	3405,3	5,9282	0,005512	3390,9	5,9007	0,005308	3376,6	5,8738
670	0,006108	3456,9	5,9958	0,005869	3443,0	5,9683	0,005647	3429,1	5,9414	0,005440	3415,4	5,9151
680	0,006246	3493,3	6,0342	0,006003	3479,8	6,0072	0,005778	3466,5	5,9808	0,005568	3453,2	5,9550
690	0,006381	3528,9	6,0714	0,006136	3515,9	6,0449	0,005907	3503,1	6,0190	0,005695	3490,3	5,9937
700	0,006513	3563,9	6,1075	0,006265	3551,4	6,0815	0,006034	3539,0	6,0561	0,005818	3526,7	6,0313
710	0,006644	3598,3	6,1427	0,006392	3586,3	6,1172	0,006158	3574,3	6,0922	0,005940	3562,4	6,0678
720	0,006772	3632,2	6,1770	0,006518	3620,6	6,1519	0,006281	3609,0	6,1273	0,006060	3597,5	6,1033
730	0,006898	3665,7	6,2105	0,006641	3654,4	6,1857	0,006401	3643,2	6,1616	0,006177	3632,0	6,1380
740	0,007022	3698,6	6,2432	0,006762	3687,7	6,2188	0,006520	3676,9	6,1950	0,006293	3666,1	6,1717
750	0,007145	3731,2	6,2752	0,006882	3720,6	6,2512	0,006637	3710,1	6,2277	0,006407	3699,7	6,2048
760	0,007266	3763,4	6,3065	0,007000	3753,2	6,2828	0,006752	3743,0	6,2597	0,006520	3732,9	6,2370
770	0,007385	3795,3	6,3372	0,007116	3785,4	6,3138	0,006865	3775,5	6,2910	0,006631	3765,7	6,2687
780	0,007503	3826,9	6,3674	0,007231	3817,3	6,3442	0,006978	3807,7	6,3217	0,006741	3798,2	6,2996
790	0,007619	3858,2	6,3969	0,007345	3848,8	6,3741	0,007088	3839,6	6,3518	0,006849	3830,4	6,3300
800	0,007734	3889,2	6,4260	0,007457	3880,2	6,4034	0,007198	3871,2	6,3814	0,006956	3862,2	6,3599

3-jadval (davomi)

t	p = 66,0 MPa			p = 68,0 MPa			p = 70,0 MPa			p = 72,0 MPa		
	v	i	s	v	i	s	v	i	s	v	i	s
0	0,0009700	64,2	- 0,0028	0,0009692	66,1	- 0,0031	0,0009683	67,9	- 0,0034	0,0009675	69,8	- 0,0037
10	0,0009717	104,1	0,1407	0,0009710	106,0	0,1403	0,0009702	107,8	0,1399	0,0009694	109,6	0,1394
20	0,0009742	144,3	0,2801	0,0009735	146,1	0,2795	0,0009727	147,9	0,2790	0,0009720	149,6	0,2784
30	0,0009774	184,6	0,4153	0,0009766	186,4	0,4146	0,0009759	188,1	0,4140	0,0009752	189,8	0,4133
40	0,0009811	225,0	0,5465	0,0009804	226,7	0,5457	0,0009796	228,4	0,5449	0,0009789	230,2	0,5441
50	0,0009853	265,5	0,6738	0,0009846	267,2	0,6729	0,0009839	268,9	0,6720	0,0009831	270,6	0,6711
60	0,0009901	306,1	0,7974	0,0009893	307,7	0,7964	0,0009886	309,4	0,7955	0,0009878	311,0	0,7945
70	0,0009952	346,7	0,9176	0,0009945	348,3	0,9165	0,0009937	350,0	0,9155	0,0009930	351,6	0,9144
80	0,0010009	387,4	1,0345	0,0010001	389,0	1,0334	0,0009993	390,6	1,0322	0,0009986	392,2	1,0310
90	0,0010069	428,2	1,1484	0,0010061	429,8	1,1472	0,0010054	431,3	1,1459	0,0010046	432,9	1,1447
100	0,0010134	469,1	1,2594	0,0010126	470,6	1,2581	0,0010118	472,1	1,2567	0,0010110	473,6	1,2554
110	0,0010204	510,0	1,3677	0,0010195	511,5	1,3662	0,0010187	513,0	1,3648	0,0010179	514,5	1,3634
120	0,0010277	551,0	1,4734	0,0010269	552,5	1,4719	0,0010260	554,0	1,4704	0,0010251	555,4	1,4689
130	0,0010355	592,2	1,5767	0,0010346	593,6	1,5751	0,0010337	595,0	1,5735	0,0010328	596,5	1,5720
140	0,0010438	633,4	1,6778	0,0010428	634,8	1,6761	0,0010419	636,2	1,6744	0,0010409	637,6	1,6728
150	0,0010525	674,8	1,7767	0,0010515	676,2	1,7750	0,0010505	677,5	1,7732	0,0010495	678,9	1,7714
160	0,0010617	716,3	1,8737	0,0010606	717,6	1,8718	0,0010596	718,9	1,8699	0,0010585	720,2	1,8681
170	0,0010714	758,0	1,9687	0,0010702	759,2	1,9668	0,0010691	760,5	1,9648	0,0010680	761,8	1,9628
180	0,0010816	799,8	2,0621	0,0010804	801,0	2,0600	0,0010792	802,2	2,0579	0,0010780	803,4	2,0558
190	0,0010923	841,8	2,1537	0,0010910	842,9	2,1515	0,0010898	844,1	2,1493	0,0010886	845,3	2,1472

t	p = 66,0 МПа			p = 68,0 МПа			p = 70,0 МПа			p = 72,0 МПа		
	v	i	s	v	i	s	v	i	s	v	i	s
200	0,0011036	884,0	2,2439	0,0011023	885,1	2,2415	0,0011010	886,2	2,2392	0,0010997	887,3	2,2370
210	0,0011156	926,4	2,3326	0,0011141	927,4	2,3301	0,0011127	928,5	2,3277	0,0011113	929,6	2,3253
220	0,0011282	969,1	2,4200	0,0011266	970,0	2,4174	0,0011251	971,0	2,4149	0,0011236	972,0	2,4123
230	0,0011415	1012,0	2,5062	0,0011398	1012,9	2,5035	0,0011382	1013,8	2,5008	0,0011366	1014,8	2,4981
240	0,0011555	1055,3	2,5913	0,0011538	1056,1	2,5885	0,0011520	1056,9	2,5856	0,0011503	1057,8	2,5828
250	0,0011704	1098,9	2,6755	0,0011685	1099,6	2,6724	0,0011666	1100,4	2,6694	0,0011647	1101,1	2,6664
260	0,0011862	1142,8	2,7588	0,0011841	1143,5	2,7555	0,0011820	1144,1	2,7523	0,0011800	1144,8	2,7492
270	0,0012030	4187,2	2,8413	0,0012007	1187,8	2,8378	0,0011984	1188,3	2,8344	0,0011962	1188,9	2,8311
280	0,0012209	1232,1	2,9231	0,0012183	1232,5	2,9194	0,0012158	1232,9	2,9158	0,0012134	1233,4	2,9123
290	0,0012399	1277,5	3,0044	0,0012371	1277,7	3,0005	0,0012344	1278,1	2,9966	0,0012317	1278,4	2,9928
300	0,0012603	1323,4	3,0,853	0,0012572	1323,5	3,0811	0,0012541	1323,7	3,0769	0,0012512	1323,9	3,0729
310	0,0012821	1370,0	3,1658	0,0012787	1369,9	3,1613	0,0012753	1369,9	3,1569	0,0012720	1369,9	3,1525
320	0,0013056	1417,2	3,2461	0,0013018	1416,9	3,2413	0,0012980	1416,7	3,2365	0,0012943	1416,6	3,2319
330	0,0013310	1465,2	3,3263	0,0013267	1464,7	3,3211	0,0013224	1464,3	3,3160	0,0013183	1463,9	3,3109
340	0,0013585	1514,0	3,4065	0,0013536	1513,2	3,4009	0,0013488	1512,5	3,3953	0,0013441	1511,9	3,3899
350	0,0013885	1563,6	3,4869	0,0013828	1562,6	3,4807	0,0013773	1561,6	3,4747	0,0013721	1560,7	3,4688
355	0,001404	1588,8	3,5271	0,001398	1587,6	3,5206	0,001393	1586,4	3,5144	0,001387	1585,3	3,5082
360	0,001421	1614,3	3,5675	0,001415	1612,8	3,5607	0,001408	1611,5	3,5541	0,001402	1610,2	3,5477
365	0,001439	1640,0	3,6080	0,001432	1638,4	3,6009	0,001425	1636,9	3,5941	0,001419	1635,4	3,5874
370	0,001457	1666,1	3,6487	0,001450	1664,3	3,6413	0,001442	1662,5	3,6341	0,001435	1660,9	3,6271
375	0,001477	1692,5	3,6896	0,001468	1690,4	3,6818	0,001461	1688,4	3,6743	0,001453	1686,6	3,6669
380	0,001497	1719,3	3,7308	0,001488	1716,9	3,7225	0,001480	1714,7	3,7146	0,001472	1712,6	3,7069
385	0,001518	1746,4	3,7721	0,001509	1743,7	3,7634	0,001500	1741,2	3,7551	0,001491	1738,9	3,7470
390	0,001541	1773,9	3,8137	0,001531	1770,9	3,8045	0,001521	1768,1	3,7957	0,001511	1765,5	3,7872
395	0,001565	1801,8	3,8556	0,001554	1798,4	3,8459	0,001543	1795,3	3,8366	0,001533	1792,4	3,8277
400	0,001590	1830,1	3,8978	0,001578	1826,4	3,8876	0,001566	1822,9	3,8778	0,001555	1819,7	3,8683
405	0,001617	1858,9	3,9404	0,001604	1854,7	3,9295	0,001591	1850,9	3,9192	0,001579	1847,3	3,9092
410	0,001646	1888,1	3,9834	0,001631	1883,5	3,9718	0,001617	1879,2	3,9609	0,001604	1875,3	3,9503
415	0,001677	1917,9	4,0268	0,001660	1912,8	4,0145	0,001645	1908,1	4,0029	0,001631	1903,7	3,9918
420	0,001709	1948,2	4,0707	0,001691	1942,6	4,0576	0,001674	1937,3	4,0453	0,001658	1932,5	4,0335
425	0,001744	1979,1	4,1151	0,001724	1972,8	4,1012	0,001705	1967,1	4,0880	0,001688	1961,8	4,0756
430	0,001781	2010,6	4,1600	0,001759	2003,7	4,1452	0,001738	1997,3	4,1312	0,001719	1991,5	4,1180
435	0,001820	2042,7	4,2055	0,001796	2035,1	4,1897	0,001773	2028,1	4,1748	0,001752	2021,7	4,1607
440	0,001863	2075,4	4,2515	0,001835	2067,0	4,2346	0,001810	2059,3	4,2188	0,001788	2052,3	4,2039
445	0,001908	2108,7	4,2981	0,001878	2099,5	4,2800	0,001850	2091,1	4,2632	0,001825	2083,4	4,2474
450	0,001956	2142,6	4,3452	0,001923	2132,6	4,3259	0,001892	2123,4	4,3080	0,001864	2115,0	4,2912
460	0,002063	2212,2	4,4408	0,002021	2200,3	4,4189	0,001984	2189,5	4,3987	0,001950	2179,6	4,3799
470	0,002184	2283,8	4,5377	0,002133	2269,9	4,5132	0,002087	2257,3	4,4906	0,002047	2245,8	4,4696
480	0,002318	2356,6	4,6351	0,002256	2340,8	4,6080	0,002202	2326,4	4,5830	0,002153	2313,3	4,5598
490	0,002465	2429,9	4,7317	0,002392	2412,3	4,7023	0,002327	2396,3	4,6752	0,002270	2381,7	4,6499
500	0,002623	2502,7	4,8265	0,002538	2483,7	4,7952	0,002463	2466,2	4,7662	0,002396	2450,2	4,7391
510	0,002788	2574,1	4,9182	0,002692	2554,0	4,8856	0,002607	2535,5	4,8552	0,002530	2518,3	4,8267
520	0,002959	2643,4	5,0062	0,002852	2622,7	4,9728	0,002757	2603,4	4,9413	0,002671	2585,4	4,9118
530	0,003132	2710,2	5,0898	0,003015	2689,3	5,0561	0,002911	2669,5	5,0242	0,002816	2650,9	4,9939
540	0,003305	2774,1	5,1690	0,003180	2753,2	5,1353	0,003067	2733,4	5,1032	0,002964	2714,6	5,0727

t	p = 66,0 MPa			p = 68,0 MPa			p = 70,0 MPa			p = 72,0 MPa		
	v	i	s	v	i	s	v	i	s	v	i	s
550	0,003476	2835,3	5,2438	0,003344	2814,7	5,2105	0,003223	2795,0	5,1786	0,003113	2776,2	5,1480
560	0,003644	2893,6	5,3141	0,003505	2873,4	5,2814	0,003378	2854,1	5,2499	0,003262	2835,5	5,2196
570	0,003809	2949,2	5,3805	0,003665	2929,6	5,3484	0,003532	2910,7	5,3175	0,003410	2892,5	5,2876
580	0,003970	3002,4	5,4433	0,003821	2983,5	5,4119	0,003683	2965,1	5,3816	0,003555	2947,2	5,3522
590	0,004127	3053,4	5,5026	0,003973	3035,1	5,4721	0,003830	3017,3	5,4424	0,003698	3000,0	5,4136
600	0,004280	3102,3	5,5590	0,004122	3084,7	5,5292	0,003975	3067,5	5,5003	0,003839	3050,7	5,4721
610	0,004428	3149,3	5,6125	0,004267	3132,4	5,5835	0,004116	3115,8	5,5553	0,003976	3099,6	5,5278
620	0,004573	3194,6	5,6636	0,004408	3178,4	5,6353	0,004254	3162,4	5,6078	0,004110	3146,8	5,5809
630	0,004714	3238,5	5,7124	0,004546	3222,9	5,6848	0,004388	3207,5	5,6579	0,004242	3192,4	5,6317
640	0,004852	3281,0	5,7592	0,004680	3266,0	5,7323	0,004520	3251,2	5,7060	0,004370	3236,6	5,6803
650	0,004986	3322,3	5,8042	0,004812	3307,8	5,7779	0,004648	3293,6	5,7522	0,004496	3279,5	5,7271
660	0,005118	3362,5	5,8475	0,004940	3348,6	5,8218	0,004774	3334,8	5,7967	0,004619	3321,3	5,7721
670	0,005246	3401,8	5,8894	0,005066	3388,4	5,8642	0,004897	3375,1	5,8396	0,004739	3362,0	5,8155
680	0,005372	3440,1	5,9298	0,005189	3427,2	5,9052	0,005018	3414,4	5,8810	0,004857	3401,7	5,8574
690	0,005496	3477,7	5,9690	0,005310	3465,2	5,9448	0,005136	3452,8	5,9211	0,004973	3440,6	5,8980
700	0,005617	3514,5	6,0070	0,005429	3502,4	5,9833	0,005252	3490,5	5,9600	0,005086	3478,6	5,9373
710	0,005736	3550,6	6,0439	0,005545	3538,9	6,0206	0,005366	3527,4	5,9978	0,005198	3515,9	5,9754
720	0,005853	3586,1	6,0799	0,005659	3574,8	6,0569	0,005478	3563,6	6,0344	0,005307	3552,6	6,0125
730	0,005968	3621,0	6,1149	0,005772	3610,1	6,0923	0,005588	3599,3	6,0702	0,005415	3588,6	6,0485
740	0,006081	3655,4	6,1490	0,005883	3644,8	6,1267	0,005697	3634,4	6,1050	0,005522	3624,0	6,0837
750	0,006193	3689,4	6,1823	0,005992	3679,1	6,1604	0,005804	3669,0	6,1390	0,005626	3658,9	6,1179
760	0,006303	3722,9	6,2149	0,006100	3712,9	6,1933	0,005909	3703,1	6,1722	0,005729	3693,3	6,1514
770	0,006412	3756,0	6,2468	0,006206	3746,4	6,2255	0,006013	3736,8	6,2046	0,005831	3727,3	6,1842
780	0,006519	3788,8	6,2781	0,006311	3779,4	6,2570	0,006115	3770,1	6,2364	0,005932	3761,0	6,2163
790	0,006625	3821,2	6,3088	0,006414	3812,1	6,2880	0,006217	3803,1	6,2676	0,006031	3794,2	6,2477
800	0,006729	3853,3	6,3388	0,006517	3844,5	6,3183	0,006317	3835,8	6,2982	0,006129	3827,2	6,2785

3-jadval (davomi)

t	p = 74,0 MPa			p = 76,0 MPa			p = 78,0 MPa			p = 80,0 MPa		
	v	i	s	v	i	s	v	i	s	v	i	s
0	0,0009667	71,6	-0,0040	0,0009659	73,5	-0,0043	0,0009651	75,3	-0,0046	0,0009643	77,2	-0,0049
10	0,0009686	111,4	0,1390	0,0009679	113,2	0,1385	0,0009671	115,0	0,1380	0,0009663	116,8	0,1376
20	0,0009712	151,4	0,2778	0,0009705	153,2	0,2772	0,0009698	154,9	0,2766	0,0009690	156,7	0,2761
30	0,0009744	191,6	0,4126	0,0009737	193,3	0,4119	0,0009730	195,0	0,4112	0,0009723	196,8	0,4105
40	0,0009782	231,9	0,5433	0,0009775	233,6	0,5425	0,0009767	235,3	0,5417	0,0009760	237,0	0,5409
50	0,0009824	272,2	0,6702	0,0009817	273,9	0,6693	0,0009810	275,6	0,6684	0,0009802	277,3	0,6675
60	0,0009871	312,7	0,7935	0,0009864	314,3	0,7925	0,0009857	316,0	0,7915	0,0009849	317,6	0,7905
70	0,0009922	353,2	0,9133	0,0009915	354,8	0,9122	0,0009908	356,4	0,9112	0,0009900	358,0	0,9101
80	0,0009978	393,8	1,0299	0,0009971	395,4	1,0287	0,0009963	397,0	1,0276	0,0009956	398,5	1,0264
90	0,0010038	434,4	1,1434	0,0010030	436,0	1,1422	0,0010023	437,6	1,1409	0,0010015	439,1	1,1397
100	0,0010102	475,2	1,2541	0,0010094	476,7	1,2527	0,0010086	478,2	1,2514	0,0010078	479,8	1,2501
110	0,0010170	516,0	1,3620	0,0010162	517,5	1,3606	0,0010154	519,0	1,3592	0,0010146	520,5	1,3578
120	0,0010243	556,9	1,4674	0,0010234	558,4	1,4659	0,0010226	559,8	1,4644	0,0010217	561,3	1,4630
130	0,0010319	597,9	1,5704	0,0010310	599,3	1,5688	0,0010302	600,8	1,5672	0,0010293	602,2	1,5657

t	p = 74,0 MPa			p = 76,0 MPa			p = 78,0 MPa			p = 80,0 MPa		
	v	i	s	v	i	s	v	i	s	v	i	s
140	0,0010400	639,0	1,6711	0,0010391	640,4	1,6694	0,0010382	641,8	1,6678	0,0010372	643,2	1,6661
150	0,0010485	680,2	1,7697	0,0010476	681,6	1,7679	0,0010466	682,9	1,7662	0,0010456	684,3	1,7645
160	0,0010575	721,6	1,8662	0,0010565	722,9	1,8644	0,0010555	724,2	1,8626	0,0010545	725,5	1,8607
170	0,0010670	763,0	1,9609	0,0010659	764,3	1,9590	0,0010648	765,6	1,9570	0,0010638	766,9	1,9551
180	0,0010769	804,7	2,0538	0,0010758	805,9	2,0518	0,0010746	807,1	2,0497	0,0010735	808,4	2,0477
190	0,0010874	846,5	2,1450	0,0010861	847,6	2,1429	0,0010850	848,8	2,1408	0,0010838	850,0	2,1387
200	0,0010984	888,4	2,2347	0,0010971	889,6	2,2325	0,0010958	890,7	2,2302	0,0010945	891,8	2,2280
210	0,0011099	930,6	2,3229	0,0011086	931,7	2,3206	0,0011072	932,8	2,3182	0,0011059	933,9	2,3159
220	0,0011221	973,0	2,4098	0,0011207	974,1	2,4073	0,0011192	975,1	2,4049	0,0011178	976,1	2,4024
230	0,0011350	1015,7	2,4955	0,0011334	1016,7	2,4929	0,0011318	1017,6	2,4902	0,0011303	1018,6	2,4877
240	0,0011485	1058,7	2,5800	0,0011468	1059,5	2,5772	0,0011452	1060,4	2,5745	0,0011435	1061,3	2,5718
250	0,0011628	1101,9	2,6635	0,0011610	1102,7	2,6606	0,0011592	1103,5	2,6577	0,0011574	1104,3	2,6548
260	0,0011780	1145,5	2,7460	0,0011760	1146,2	2,7429	0,0011740	1146,9	2,7399	0,0011721	1147,7	2,7368
270	0,0011940	1189,5	2,8278	0,0011918	1190,1	2,8245	0,0011897	1190,7	2,8212	0,0011876	1191,4	2,8180
280	0,0012110	1233,9	2,9087	0,0012086	1234,4	2,9053	0,0012063	1234,9	2,9018	0,0012040	1235,4	2,8984
290	0,0012290	1278,7	2,9891	0,0012264	1279,1	2,9854	0,0012239	1279,5	2,9817	0,0012214	1279,9	2,9781
300	0,0012482	1324,1	3,0689	0,0012454	1324,3	3,0650	0,0012426	1324,6	3,0611	0,0012398	1324,9	3,0572
310	0,0012687	1370,0	3,1483	0,0012656	1370,0	3,1440	0,0012625	1370,1	3,1399	0,0012594	1370,3	3,1358
320	0,0012907	1416,4	3,2273	0,0012872	1416,3	3,2228	0,0012837	1416,3	3,2183	0,0012804	1416,3	3,2140
330	0,0013142	1463,5	3,3060	0,0013103	1463,2	3,3012	0,0013065	1463,0	3,2964	0,0013027	1462,8	3,2918
340	0,0013396	1511,3	3,3846	0,0013352	1510,8	3,3794	0,0013309	1510,3	3,3743	0,0013267	1509,9	3,3693
350	0,0013669	1559,8	3,4630	0,0013620	1559,0	3,4574	0,0013571	1558,3	3,4519	0,0013525	1557,7	3,4465
355	0,001381	1584,3	3,5022	0,001376	1583,4	3,4964	0,001371	1582,6	3,4907	0,001366	1581,8	3,4851
360	0,001397	1609,1	3,5415	0,001391	1608,0	3,5354	0,001385	1607,0	3,5294	0,001380	1606,1	3,5236
365	0,001412	1634,1	3,5808	0,001406	1632,9	3,5745	0,001400	1631,7	3,5683	0,001395	1630,6	3,5622
370	0,001429	1659,4	3,6203	0,001422	1657,9	3,6136	0,001416	1656,6	3,6072	0,001410	1655,4	3,6008
375	0,001446	1684,9	3,6598	0,001439	1683,3	3,6528	0,001432	1681,8	3,6461	0,001426	1680,4	3,6395
380	0,001464	1710,7	3,6994	0,001457	1708,8	3,6922	0,001449	1707,1	3,6851	0,001443	1705,6	3,6783
385	0,001483	1736,7	3,7392	0,001475	1734,7	3,7316	0,001467	1732,8	3,7242	0,001460	1731,0	3,7171
390	0,001502	1763,1	3,7790	0,001494	1760,8	3,7711	0,001486	1758,7	3,7634	0,001478	1756,7	3,7559
395	0,001523	1789,7	3,8191	0,001514	1787,2	3,8107	0,001505	1784,8	3,8027	0,001497	1782,6	3,7948
400	0,001545	1816,7	3,8593	0,001535	1813,9	3,8505	0,001525	1811,2	3,8421	0,001516	1808,8	3,8339
405	0,001568	1844,0	3,8997	0,001557	1840,8	3,8905	0,001547	1837,9	3,8816	0,001537	1835,2	3,8730
410	0,001592	1871,6	3,9403	0,001580	1868,2	3,9306	0,001569	1865,0	3,9213	0,001558	1861,9	3,9123
415	0,001617	1899,6	3,9811	0,001604	1895,8	3,9709	0,001592	1892,3	3,9612	0,001581	1889,0	3,9517
420	0,001644	1928,0	4,0223	0,001630	1923,9	4,0115	0,001617	1920,0	4,0012	0,001605	1916,3	3,9913
425	0,001672	1956,8	4,0637	0,001657	1952,3	4,0524	0,001643	1948,0	4,0415	0,001630	1944,0	4,0311
430	0,001702	1986,1	4,1054	0,001685	1981,1	4,0934	0,001670	1976,4	4,0820	0,001656	1972,0	4,0711
435	0,001733	2015,7	4,1474	0,001715	2010,2	4,1348	0,001699	2005,1	4,1228	0,001683	2000,4	4,1113
440	0,001767	2045,8	4,1898	0,001747	2039,8	4,1765	0,001729	2034,3	4,1638	0,001712	2029,1	4,1517
445	0,001802	2076,4	4,2325	0,001780	2069,8	4,2184	0,001761	2063,8	4,2050	0,001742	2058,2	4,1923
450	0,001839	2107,4	4,2755	0,001816	2100,2	4,2606	0,001794	2093,7	4,2465	0,001774	2087,6	4,2331
460	0,001920	2170,6	4,3623	0,001892	2162,2	4,3457	0,001866	2154,6	4,3301	0,001842	2147,4	4,3153
470	0,002010	2235,3	4,4500	0,001976	2225,7	4,4317	0,001946	2216,8	4,4144	0,001918	2208,6	4,3982

t	p = 74,0 MПа			p = 76,0 MПа			p = 78,0 MПа			p = 80,0 MПа		
	v	i	s	v	i	s	v	i	s	v	i	s
480	0,002109	2301,4	4,5383	0,002070	2290,3	4,5181	0,002034	2280,2	4,4992	0,002001	2270,8	4,4814
490	0,002218	2368,2	4,6264	0,002171	2355,9	4,6045	0,002129	2344,5	4,5839	0,002091	2333,9	4,5646
500	0,002336	2435,4	4,7139	0,002282	2421,8	4,6903	0,002233	2409,2	4,6682	0,002188	2397,6	4,6474
510	0,002461	2502,4	4,8000	0,002399	2487,7	4,7750	0,002343	2474,0	4,7515	0,002292	2461,3	4,7294
520	0,002593	2568,6	4,8840	0,002524	2552,9	4,8578	0,002460	2538,4	4,8332	0,002403	2524,8	4,8099
530	0,002730	2633,5	4,9653	0,002653	2617,2	4,9383	0,002582	2601,9	4,9128	0,002518	2587,6	4,8886
540	0,002871	2696,8	5,0437	0,002786	2680,1	5,0161	0,002708	2664,3	4,9899	0,002637	2649,4	4,9651
550	0,003013	2758,3	5,1188	0,002921	2741,2	5,0909	0,002837	2725,2	5,0644	0,002760	2709,9	5,0391
560	0,003155	2817,7	5,1906	0,003058	2800,7	5,1627	0,002968	2784,5	5,1360	0,002885	2769,0	5,1103
570	0,003297	2874,9	5,2588	0,003194	2858,1	5,2311	0,003098	2841,9	5,2045	0,003010	2826,4	5,1789
580	0,003438	2930,0	5,3238	0,003329	2913,4	5,2964	0,003228	2897,4	5,2699	0,003135	2882,0	5,2445
590	0,003576	2983,1	5,3857	0,003463	2966,8	5,3587	0,003358	2951,1	5,3325	0,003260	2935,9	5,3072
600	0,003712	3034,4	5,4447	0,003595	3018,5	5,4181	0,003485	3003,0	5,3923	0,003384	2988,1	5,3674
610	0,003846	3083,8	5,5010	0,003724	3068,3	5,4749	0,003611	3053,3	5,4495	0,003506	3038,6	5,4249
620	0,003977	3131,4	5,5547	0,003852	3116,5	5,5291	0,003735	3101,8	5,5042	0,003626	3087,6	5,4800
630	0,004105	3177,6	5,6060	0,003977	3163,1	5,5810	0,003857	3148,9	5,5566	0,003744	3135,0	5,5328
640	0,004230	3222,3	5,6552	0,004099	3208,2	5,6307	0,003976	3194,5	5,6068	0,003861	3181,0	5,5835
650	0,004353	3265,7	5,7025	0,004219	3252,1	5,6785	0,004093	3238,8	5,6551	0,003975	3225,7	5,6321
660	0,004473	3307,9	5,7480	0,004336	3294,8	5,7245	0,004208	3281,9	5,7015	0,004087	3269,2	5,6790
670	0,004591	3349,1	5,7919	0,004451	3336,4	5,7688	0,004320	3323,9	5,7463	0,004197	3311,6	5,7242
680	0,004706	3389,3	5,8343	0,004564	3377,0	5,8117	0,004431	3364,9	5,7895	0,004306	3352,9	5,7678
690	0,004819	3428,5	5,8753	0,004675	3416,6	5,8531	0,004540	3404,9	5,8313	0,004412	3393,4	5,8100
700	0,004931	3467,0	5,9150	0,004784	3455,5	5,8932	0,004646	3444,1	5,8718	0,004516	3432,9	5,8509
710	0,005040	3504,7	5,9535	0,004891	3493,5	5,9321	0,004751	3482,5	5,9111	0,004619	3471,7	5,8905
720	0,005147	3541,6	5,9909	0,004996	3530,8	5,9698	0,004854	3520,2	5,9492	0,004720	3509,7	5,9290
730	0,005253	3578,0	6,0273	0,005100	3567,5	6,0066	0,004955	3557,2	5,9862	0,004819	3547,0	5,9663
740	0,005357	3613,7	6,0628	0,005202	3603,6	6,0424	0,005055	3593,5	6,0223	0,004917	3583,6	6,0027
750	0,005459	3648,9	6,0974	0,005302	3639,1	6,0772	0,005154	3629,4	6,0575	0,005013	3619,7	6,0382
760	0,005560	3683,7	6,1312	0,005401	3674,1	6,1113	0,005251	3664,7	6,0918	0,005108	3655,3	6,0728
770	0,005660	3718,0	6,1642	0,005499	3708,7	6,1446	0,005346	3699,5	6,1254	0,005202	3690,4	6,1066
780	0,005758	3751,9	6,1965	0,005595	3742,8	6,1772	0,005441	3733,9	6,1583	0,005295	3725,1	6,1397
790	0,005855	3785,4	6,2282	0,005690	3776,6	6,2091	0,005534	3768,0	6,1904	0,005386	3759,4	6,1721
800	0,005951	3818,6	6,2593	0,005784	3810,1	6,2404	0,005626	3801,7	6,2220	0,005476	3793,3	6,2039

3-jadval (davomi)

t	p = 85,0 MПа			p = 90,0 MПа			p = 95,0 MПа			p = 100,0 MПа		
	v	i	s	v	i	s	v	i	s	v	i	s
0	0,0009624	81,8	-0,0058	0,0009605	86,3	-0,0066	0,0009586	90,9	-0,0076	0,0009567	95,4	-0,0086
10	0,0009645	121,3	0,1364	0,0009626	125,8	0,1352	0,0009608	130,2	0,1339	0,0009590	134,7	0,1326
20	0,0009672	161,1	0,2746	0,0009654	165,5	0,2730	0,0009636	169,9	0,2715	0,0009619	174,2	0,2700
30	0,0009705	201,1	0,4087	0,0009687	205,4	0,4069	0,0009670	209,7	0,4052	0,0009652	214,0	0,4034
40	0,0009742	241,2	0,5389	0,0009725	245,5	0,5369	0,0009708	249,7	0,5349	0,0009691	253,9	0,5329
50	0,0009785	281,4	0,6653	0,0009767	285,6	0,6631	0,0009750	289,8	0,6609	0,0009733	293,9	0,6586
60	0,0009831	321,7	0,7881	0,0009814	325,8	0,7857	0,0009796	329,9	0,7832	0,0009779	334,0	0,7808

t	p = 85,0 МПа			p = 90,0 МПа			p = 95,0 МПа			p = 100,0 МПа		
	v	i	s	v	i	s	v	i	s	v	i	s
70	0,0009882	362,1	0,9075	0,0009865	366,1	0,9048	0,0009847	370,1	0,9022	0,0009830	374,2	0,8996
80	0,0009937	402,5	1,0236	0,0009919	406,5	1,0207	0,0009901	410,4	1,0179	0,0009883	414,4	1,0151
90	0,0009996	443,0	1,1367	0,0009978	446,9	1,1336	0,0009959	450,8	1,1306	0,0009941	454,7	1,1276
100	0,0010059	483,6	1,2469	0,0010040	487,4	1,2436	0,0010021	491,2	1,2404	0,0010002	495,0	1,2373
110	0,0010126	524,2	1,3544	0,0010106	528,0	1,3509	0,0010087	531,7	1,3476	0,0010067	535,5	1,3442
120	0,0010197	565,0	1,4593	0,0010176	568,6	1,4557	0,0010156	572,3	1,4521	0,0010136	576,0	1,4486
130	0,0010271	605,8	1,5618	0,0010250	609,4	1,5580	0,0010229	613,0	1,5542	0,0010208	616,6	1,5505
140	0,0010350	646,7	1,6621	0,0010328	650,2	1,6581	0,0010306	653,7	1,6541	0,0010284	657,2	1,6502
150	0,0010433	687,7	1,7602	0,0010410	691,1	1,7560	0,0010387	694,6	1,7518	0,0010364	698,0	1,7477
160	0,0010520	728,8	1,8562	0,0010496	732,2	1,8518	0,0010472	735,5	1,8474	0,0010448	738,9	1,8431
170	0,0010611	770,1	1,9504	0,0010586	773,3	1,9458	0,0010561	776,6	1,9412	0,0010536	779,8	1,9366
180	0,0010708	811,5	2,0428	0,0010681	814,6	2,0379	0,0010654	817,8	2,0331	0,0010628	820,9	2,0283
190	0,0010808	853,0	2,1334	0,0010780	856,0	2,1283	0,0010752	859,1	2,1233	0,0010725	862,2	2,1183
200	0,0010914	894,7	2,2225	0,0010884	897,6	2,2171	0,0010855	900,6	2,2119	0,0010826	903,5	2,2066
210	0,0011026	936,6	2,3101	0,0010993	939,4	2,3045	0,0010962	942,2	2,2989	0,0010931	945,0	2,2935
220	0,0011143	978,7	2,3964	0,0011108	981,3	2,3904	0,0011075	984,0	2,3846	0,0011042	986,7	2,3789
230	0,0011265	1021,0	2,4813	0,0011229	1023,5	2,4751	0,0011193	1026,0	2,4690	0,0011158	1028,6	2,4630
240	0,0011394	1063,6	2,5651	0,0011355	1065,9	2,5585	0,0011317	1068,3	2,5521	0,0011280	1070,7	2,5458
250	0,0011530	1106,4	2,6477	0,0011488	1108,6	2,6408	0,0011447	1110,8	2,6341	0,0011407	1113,0	2,6275
260	0,0011674	1149,5	2,7294	0,0011628	1151,5	2,7221	0,0011584	1153,5	2,7151	0,0011541	1155,6	2,7081
270	0,0011825	1193,0	2,8102	0,0011775	1194,7	2,8025	0,0011727	1196,6	2,7950	0,0011681	1198,5	2,7878
280	0,0011984	1236,8	2,8901	0,0011930	1238,3	2,8820	0,0011879	1239,9	2,8742	0,0011829	1241,6	2,8665
290	0,0012153	1281,0	2,9693	0,0012094	1282,3	2,9608	0,0012038	1283,6	2,9525	0,0011984	1285,1	2,9444
300	0,0012331	1325,7	3,0479	0,0012268	1326,6	3,0388	0,0012207	1327,7	3,0300	0,0012148	1328,9	3,0215
310	0,0012521	1370,8	3,1259	0,0012451	1371,4	3,1163	0,0012385	1372,2	3,1070	0,0012321	1373,1	3,0980
320	0,0012723	1416,3	3,2034	0,0012646	1416,6	3,1931	0,0012573	1417,1	3,1833	0,0012503	1417,7	3,1738
330	0,0012938	1462,4	3,2804	0,0012853	1462,3	3,2695	0,0012773	1462,4	3,2591	0,0012696	1462,7	3,2490
340	0,0013167	1509,1	3,3571	0,0013073	1508,5	3,3455	0,0012985	1508,2	3,3344	0,0012901	1508,1	3,3236
350	0,0013413	1556,3	3,4335	0,0013309	1555,2	3,4211	0,0013210	1554,4	3,4092	0,0013118	1553,9	3,3978
355	0,001354	1580,1	3,4716	0,001343	1578,8	3,4587	0,001045	1078,6	2,6124	0,001046	1090,0	2,6223
360	0,001368	1604,1	3,5096	0,001356	1602,5	3,4963	0,001345	1601,2	3,4836	0,001335	1600,2	3,4715
365	0,001382	1628,3	3,5477	0,001369	1626,4	3,5339	0,001358	1624,8	3,5207	0,001347	1623,6	3,5082
370	0,001396	1652,7	3,5857	0,001383	1650,4	3,5714	0,001371	1648,6	3,5578	0,001359	1647,1	3,5449
375	0,001411	1677,3	3,6238	0,001397	1674,6	3,6089	0,001384	1672,5	3,5949	0,001372	1670,7	3,5815
380	0,001427	1702,0	3,6619	0,001412	1699,1	3,6465	0,001398	1696,6	3,6319	0,001385	1694,5	3,6181
385	0,001443	1727,0	3,7000	0,001427	1723,7	3,6840	0,001413	1720,8	3,6689	0,001399	1718,4	3,6546
390	0,001460	1752,2	3,7381	0,001443	1748,4	3,7215	0,001428	1745,2	3,7058	0,001413	1742,5	3,6910
395	0,001477	1777,6	3,7763	0,001459	1773,4	3,7590	0,001443	1769,8	3,7428	0,001428	1766,8	3,7274
400	0,001495	1803,3	3,8145	0,001476	1798,6	3,7965	0,001459	1794,6	3,7797	0,001443	1791,1	3,7638
405	0,001514	1829,1	3,8528	0,001494	1823,9	3,8341	0,001476	1819,5	3,8166	0,001459	1815,7	3,8001
410	0,001534	1855,2	3,8912	0,001513	1849,5	3,8716	0,001493	1844,6	3,8534	0,001475	1840,4	3,8364
415	0,001555	1881,6	3,9296	0,001532	1875,3	3,9092	0,001511	1869,9	3,8903	0,001492	1865,2	3,8727
420	0,001577	1908,2	3,9682	0,001552	1901,3	3,9469	0,001529	1895,4	3,9272	0,001509	1890,3	3,9089
425	0,001599	1935,1	4,0069	0,001573	1927,6	3,9847	0,001549	1921,1	3,9642	0,001527	1915,5	3,9452
430	0,001623	1962,3	4,0457	0,001594	1954,1	4,0225	0,001569	1947,0	4,0012	0,001546	1940,9	3,9814

t	p = 85,0 МПа			p = 90,0 МПа			p = 95,0 МПа			p = 100,0 МПа		
	v	i	s	v	i	s	v	i	s	v	i	s
435	0,001648	1989,8	4,0846	0,001617	1980,8	4,0604	0,001590	1973,1	4,0382	0,001565	1966,5	4,0177
440	0,001674	2017,6	4,1237	0,001641	2007,9	4,0984	0,001612	1999,5	4,0753	0,001586	1992,3	4,0540
445	0,001701	2045,7	4,1630	0,001665	2035,1	4,1365	0,001634	2026,1	4,1125	0,001606	2018,3	4,0903
450	0,001729	2074,1	4,2024	0,001691	2062,7	4,1747	0,001658	2052,9	4,1497	0,001628	2044,5	4,1267
460	0,001790	2131,7	4,2815	0,001746	2118,5	4,2514	0,001708	2107,2	4,2242	0,001674	2097,4	4,1994
470	0,001857	2190,5	4,3612	0,001805	2175,3	4,3284	0,001761	2162,3	4,2989	0,001723	2151,2	4,2722
480	0,001929	2250,3	4,4410	0,001870	2233,0	4,4055	0,001820	2218,3	4,3737	0,001776	2205,6	4,3450
490	0,002008	2310,8	4,5209	0,001939	2291,4	4,4825	0,001882	2274,9	4,4484	0,001833	2260,7	4,4176
500	0,002092	2371,9	4,6004	0,002014	2350,3	4,5593	0,001949	2332,0	4,5227	0,001893	2316,2	4,4899
510	0,002183	2433,3	4,6793	0,002094	2409,6	4,6355	0,002020	2389,5	4,5966	0,001957	2372,1	4,5618
520	0,002279	2494,6	4,7571	0,002179	2469,0	4,7108	0,002096	2447,1	4,6697	0,002025	2428,3	4,6330
530	0,002380	2555,6	4,8335	0,002268	2528,2	4,7850	0,002175	2504,7	4,7419	0,002097	2484,4	4,7033
540	0,002485	2615,9	4,9081	0,002361	2587,0	4,8578	0,002258	2562,1	4,8129	0,002172	2540,4	4,7726
550	0,002594	2675,3	4,9807	0,002458	2645,2	4,9288	0,002345	2619,0	4,8824	0,002250	2596,1	4,8407
560	0,002705	2733,6	5,0511	0,002557	2702,5	4,9981	0,002434	2675,3	4,9504	0,002330	2651,3	4,9074
570	0,002818	2790,6	5,1192	0,002658	2758,9	5,0653	0,002526	2730,8	5,0166	0,002413	2706,0	4,9726
580	0,002931	2846,2	5,1848	0,002761	2814,1	5,1304	0,002619	2785,4	5,0810	0,002498	2759,9	5,0361
590	0,003045	2900,3	5,2478	0,002865	2868,1	5,1933	0,002713	2839,0	5,1435	0,002585	2812,9	5,0980
600	0,003159	2952,9	5,3084	0,002970	2920,8	5,2540	0,002809	2891,5	5,2040	0,002672	2865,1	5,1580
610	0,003272	3004,0	5,3666	0,003074	2972,2	5,3125	0,002905	2943,0	5,2626	0,002761	2916,4	5,2165
620	0,003383	3053,6	5,4224	0,003177	3022,2	5,3689	0,003001	2993,3	5,3192	0,002850	2966,7	5,2731
630	0,003494	3101,8	5,4761	0,003280	3070,9	5,4231	0,003096	3042,2	5,3738	0,002938	3015,9	5,3279
640	0,003603	3148,6	5,5276	0,003382	3118,3	5,4753	0,003191	3090,0	5,4263	0,003026	3063,8	5,3806
650	0,003710	3194,1	5,5772	0,003482	3164,4	5,5255	0,003285	3136,6	5,4770	0,003114	3110,6	5,4316
660	0,003816	3238,5	5,6250	0,003582	3209,4	5,5741	0,003379	3182,1	5,5261	0,003202	3156,4	5,4809
670	0,003920	3281,8	5,6711	0,003680	3253,4	5,6209	0,003471	3226,6	5,5735	0,003289	3201,3	5,5288
680	0,004022	3324,0	5,7157	0,003777	3296,4	5,6663	0,003563	3270,1	5,6195	0,003376	3245,3	5,5752
690	0,004123	3365,3	5,7588	0,003872	3338,4	5,7101	0,003653	3312,8	5,6640	0,003461	3288,4	5,6202
700	0,004222	3405,7	5,8005	0,003966	3379,5	5,7526	0,003743	3354,6	5,7071	0,003546	3330,8	5,6640
710	0,004320	3445,2	5,8409	0,004059	3419,8	5,7938	0,003831	3395,5	5,7490	0,003630	3372,3	5,7064
720	0,004415	3484,0	5,8801	0,004150	3459,3	5,8337	0,003917	3435,6	5,7896	0,003712	3413,0	5,7476
730	0,004510	3522,0	5,9183	0,004240	3498,0	5,8725	0,004003	3475,0	5,8290	0,003794	3452,9	5,7876
740	0,004603	3559,4	5,9553	0,004329	3536,1	5,9103	0,004087	3513,6	5,8674	0,003874	3492,1	5,8265
750	0,004695	3596,2	5,9915	0,004416	3573,5	5,9470	0,004170	3551,6	5,9047	0,003953	3530,7	5,8644
760	0,004785	3632,5	6,0267	0,004502	3610,4	5,9829	0,004253	3589,1	5,9411	0,004031	3568,6	5,9013
770	0,004874	3668,2	6,0612	0,004587	3646,7	6,0179	0,004334	3625,9	5,9766	0,004109	3606,0	5,9373
780	0,004963	3703,5	6,0948	0,004671	3682,5	6,0521	0,004414	3662,3	6,0113	0,004185	3642,8	5,9724
790	0,005050	3738,4	6,1278	0,004754	3718,0	6,0856	0,004493	3698,2	6,0453	0,004261	3679,2	6,0068
800	0,005135	3772,9	6,1601	0,004836	3753,0	6,1184	0,004571	3733,8	6,0785	0,004336	3715,2	6,0405

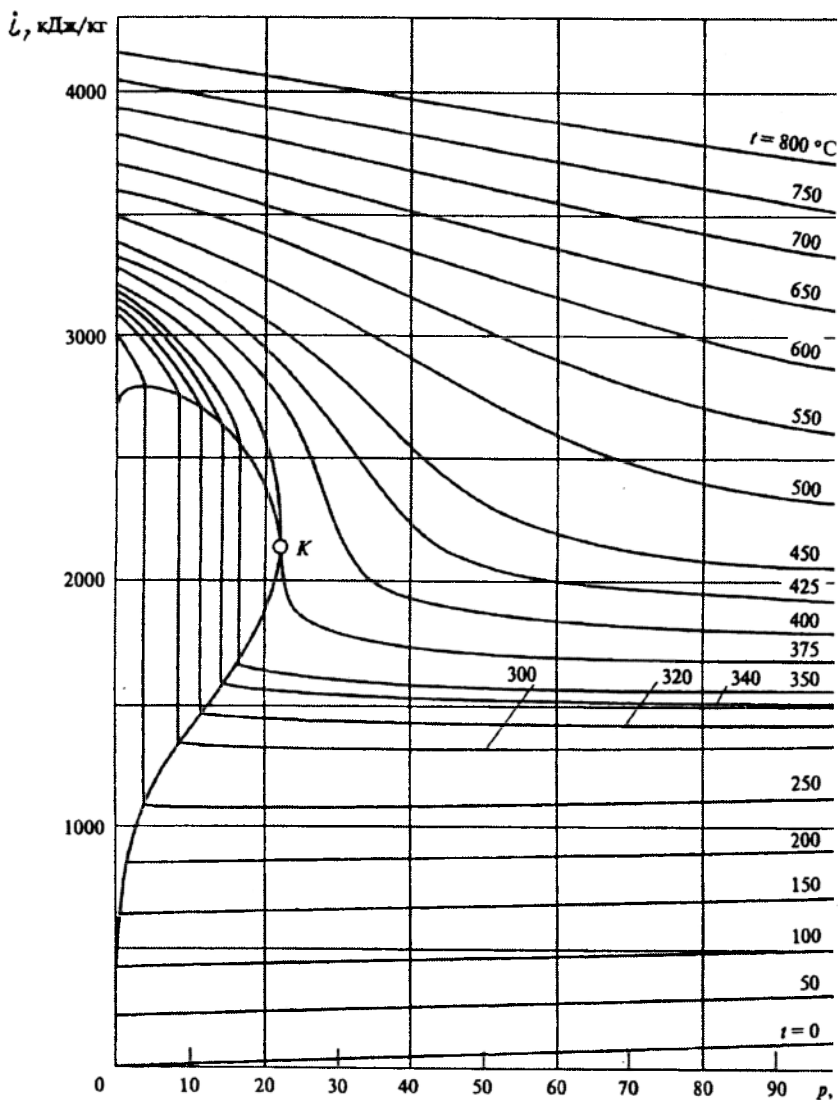

1-rasm. Suv va suv bug‘larining solishtirma entalpiya harorat va bosimga bog‘liqligi

c_p , кДж/(кг · К)

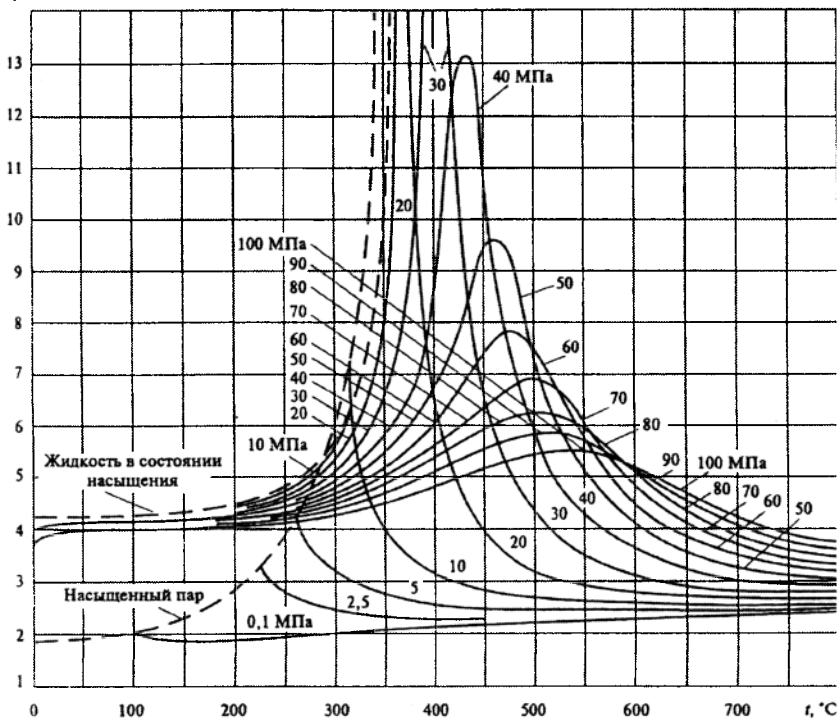

2-rasm. Suv va suv bug'larining isobarik issiqlik sig'iminin harorat va bosimga bog'liqligi

$\mu, 10^6 \text{ Па} \cdot \text{с}$

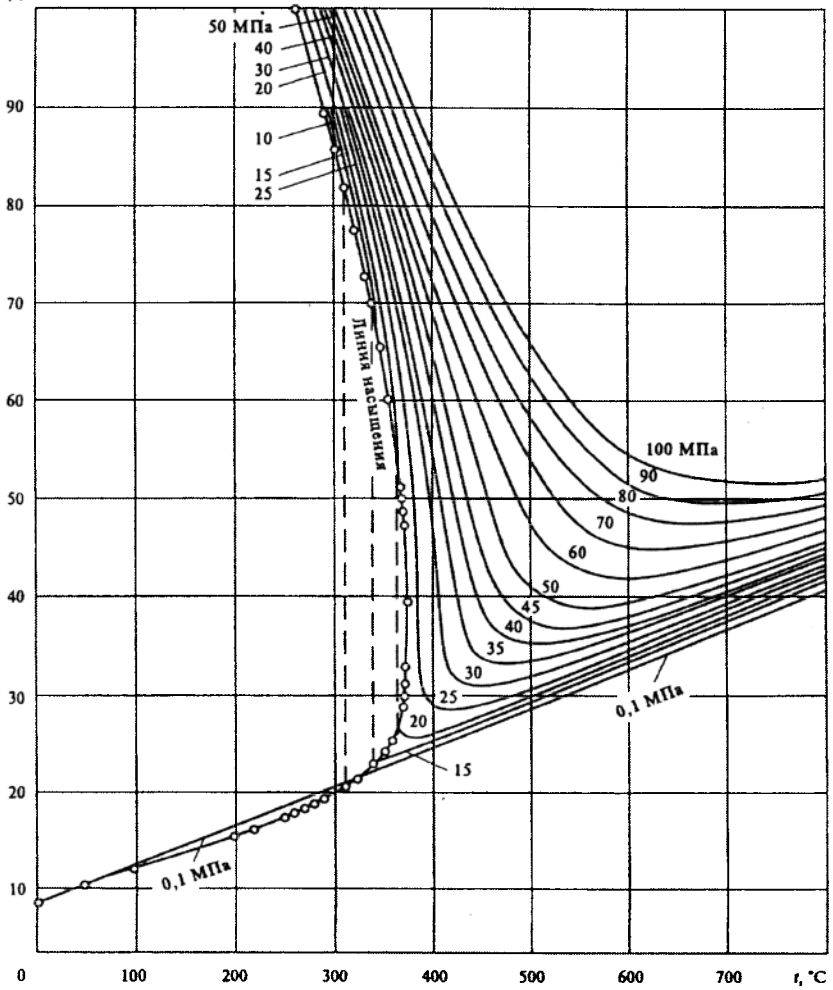

3-расм. Сув ва сув буғ'ларining динамик қотishқoқлиги harorat va bosim koeffitsiyentiga bog'liqligi

$\lambda, \text{ мВт}/(\text{м} \cdot \text{К})$

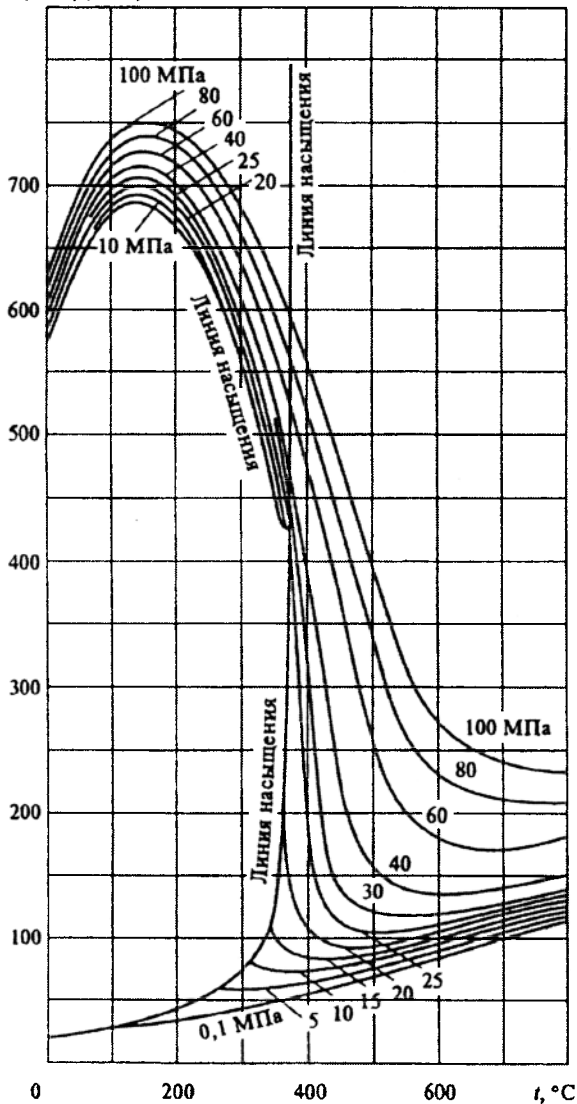

4-рasm. Suv va suv bug' issiqlik va bosimning issiqlik o'tkazuvchanligiga bog'liqligi

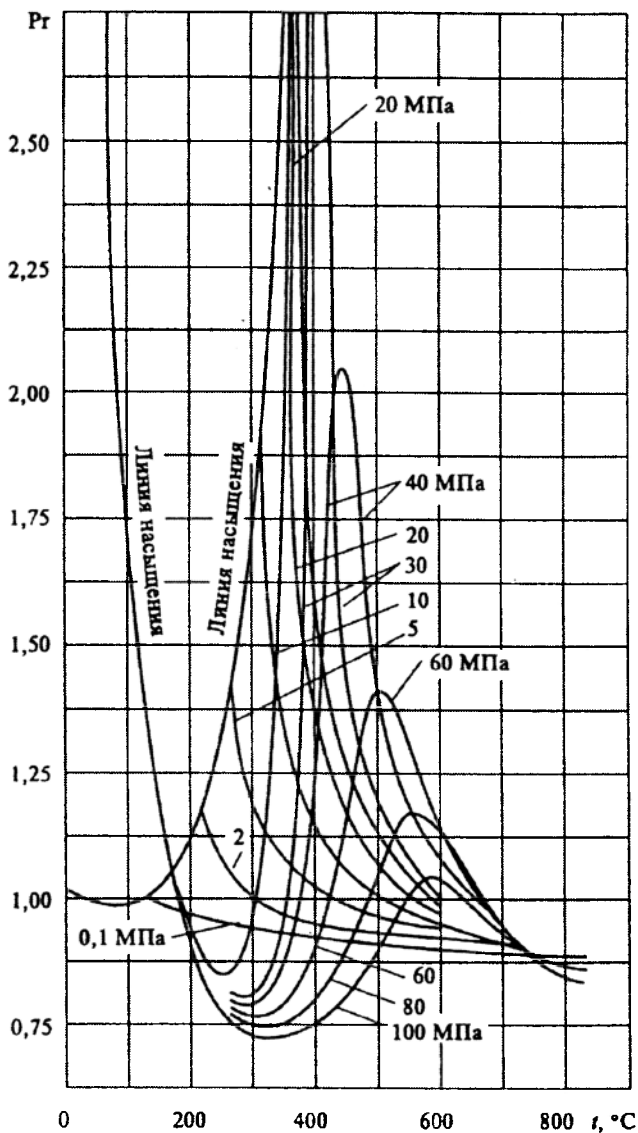

5-рasm. Prandtl suv va suv bug'i miqdorini harorat va bosimga bog'liqligi

MUNDARIJA

Soʻz boshi.....	3
Asosiy shartli belgilar	4

1-BOB. TEXNIK TERMODINAMIKA

1.1. Ishchi jism holatining termik parametrlari. Ideal gazlar holatining asosiy qonunlari va tenglamalari	5
1.2. Gaz aralashmalari. Gazlar va gaz aralashmalarining issiqlik sigʻimlari	14
1.3. Ideal gazlar holatining oʻzgarishiga doir termodinamik jarayonlar	24
1.4. Suv va suv bugʻi xossalari. Suv bugʻi jarayonlari	35
1.5. Nam havo	45
1.6. Bugʻ – kuch uskunasi (BKU) sikli. Bugʻni qizdirish bilan kechadigan Renkin sikli	54

2-BOB. ISSIQLIK VA MASSA ALMASHINUV ASOSLARI

2.1. Statsionar issiqlik uzatish jarayoni	61
2.2. Konvektiv issiqlik almashinuv.....	68
2.3. Bugʻlar kondensatsiyalanib, suyuqliklar qaynashida konvektiv issiqlik almashinuv.....	76
2.4. Nurlanish orqali issiqlik almashinuv	84
2.5. Issiqlik almashgich apparatlari	90
Tavsiya etiladigan adabiyotlar	101
Ilova	102

O.S. ABLYALIMOV

TERMODINAMIKA

I QISM

«O‘zbekiston xalqaro islom akademiyasi»
nashriyot-matbaa birlashmasi
Toshkent – 2020

Nashr uchun mas’ul: **I.Ashurmatov**
Muharrir: **V.ibragimova**
Badiiy muharrir: **F.Sobirov**
Dizayner sahifalovchi: **L.Abdullayev**

Nashriyot litsenziya raqami AA № 0011. 06.05.2019 yil.
Bosmaxonaga 26.10.2020 yilda berildi.
Bichimi 60×84 ¼. Shartli b.t. 11,1. Nashr t. 11,4.
Adadi 200 nusxa. Buyurtma № 52.
Bahosi shartnoma asosida.

O‘zbekiston xalqaro islom akademiyasi
nashriyot-matbaa birlashmasi bosmaxonasida chop etildi.
100011. Toshkent sh. A.Qodiriy, 11.